



# A-11646

## AMBER WARNING BEACON KIT

Note: This kit requires a minimum current draw of 1 amp at 12 VDC. Do not exceed the machine's available alternator capacity. If you do not know how much current is available, contact your dealer or manufacturer of this machine, prior to installing this kit.

This kit is for use with and without headliner Kit A-11638, which includes a main feed breaker and relay wire harness, 10-slot fuse block, accessories and switches wire harnesses.

Before you begin, read these instructions and identify all components. Please retain these instructions for future reference and parts ordering information.

**Kit Components:**

ITEM	QTY	PART NO.	DESCRIPTION
1	1	3-23416	AMBER LED-STROBE LIGHT 12VDC
2	1	3-18189	ROCKER SWITCH BODY ON-OFF-LIT
3	1	3-18513	ROCKER SWITCH ACTUATOR W/ BEACON IMP
4	2	3-16074	TERMINAL BLADE 1/4" MALE 16 GA
5	1	3-16582	FUSE, 2 AMP ATO/ATC BLADE TYPE
6	1	05-10830	MOUNTING INSTRUCTIONS A-11646
7	1	3-18691	FOAM SEAL RING FOR STROBE LIGHT
8	3	3-18808	No. 8 x 1.00" LONG BUTTON HEAD SCREW
9	3	3-18322	No. 6 FLAT WASHER
10	3	3-10225	No. 8 LOCK WASHER
11	3	3-14155	No. 8 HEX NUT
12	4	3-16629	NYLON TIE
13	4	3-17517	NYLON TIE PAD PSA BACK

**WIRE COMPONENTS 17-25 ARE FOR USE WITHOUT HEADLINER**

17	1	3-18231	FUSE HOLDER
18	1	3-10672	BUTT SPLICE 14 GA
19	1	3-18519	FUSE HOLDER COVER
20	2	3-10669	TERMINAL RING 5/16"
21	1	3-10345	WIRE, BLACK, 14GA X 11 FT
22	1	3-10364	WIRE, RED, 14GA X 14 FT
23	1	3-18859	TOGGLE SWITCH, ON-OFF SPST
24	4	3-10670	TERMINAL BLADE CONNECTOR, 14GA FEMALE
25	1	3-10704	WIRE LOOM, .350" X 9 FT

## ROOF TOP INSTALLATION:

1. Make sure machine's ignition key is turned off.
2. Select a roof top location for strobe light. Make sure location is not too far rearward.
3. Using the gasket as a template supplied with kit, layout and drill (3) 3/16" mount holes.
4. Drill (1) 3/8" hole in the center of the 3/16" hole pattern for electrical wire harness access.
5. Route strobe light wires to inside of roof.
6. Secure strobe light and foam seal ring to top of roof using (3) No. 8 x 1.00" long button head screws, (3) No.6 flat washers, (3) No.8 lock washers and (3) No.8 nylock nuts.

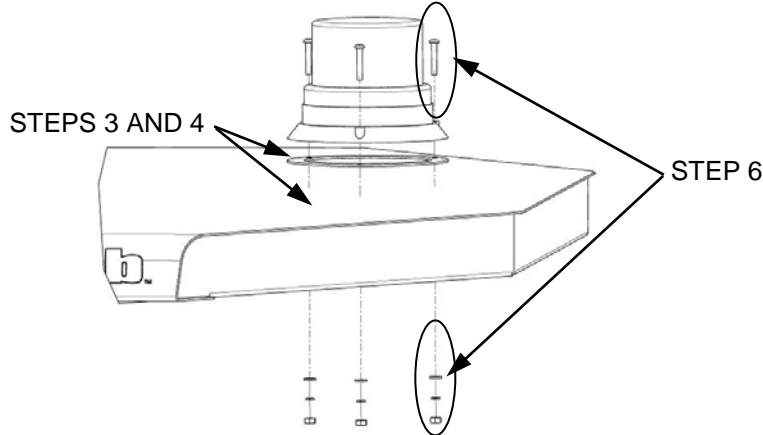

7. Using a wire crimping tool, attach (2) 1/4" male terminal blade connectors to each of the strobe light wires.

## Follow steps 8-25 for cabs with headliners (For cabs without headliners skip to step 26);

8. If headliner is already installed, remove the (4) 5/16" x 2.50" long button head bolts that secure the headliner to the inside of cab frame. Allow headliner to tip down and pivot rearward.
9. Locate switch to accessory wire harness 3-19281, supplied with headliner kit. Identify wire harness end for warning beacon connection and route wires along one side of roof cab to strobe light location.
10. Connect gray wire with female blade connector to red wire of strobe light
11. Connect black wire with female blade connector to black wire of strobe light.
12. Select a location in headliner for rocker switch location. Remove rectangular hole plug.
13. Route wire harness from inside area of headliner and through rocker switch hole.
14. Connect gray wire from strobe light to rocker switch terminal 3. See figure 3.
15. Connect the black wire with 1/4" terminal eye, from the strobe light to a ground stud.
16. Install rocker switch and switch actuator into headliner.
17. Remove fuse block access cover panel and select an empty fuse location.
18. Locate fuse block to switches wire harness 3-19282, supplied with headliner kit.
19. Connect gray wire of harness from rocker switch terminal 2 to the empty fuse block location.
20. Connect the black wire from the rocker switch terminal 7 to a ground stud.

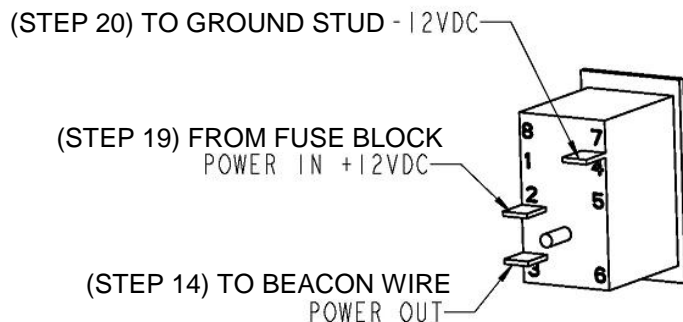

**Figure 2**  
**ROCKER SWITCH 3-18189**  
20A MAX AT 12VDC  
TYPICAL SWITCH WIRING

05-10830  
May 14, 2018

21. Install 2 amp fuse.
22. Turn tractor's ignition key "On" and check strobe light operation by turning the beacon rocker switch, on and off.
23. Secure wire harness with nylon ties and tie pads with PSA backing.
24. Secure headliner to cab.
25. Secure fuse block access cover panel to headliner.

**Headliner Note:** Refer to drawings 4-15389, 3-19281 and 3-19282 supplied with mounting instructions in Headliner Kit A-11638 for detailed wiring and additional information.

**Follow steps 26-33 for cabs without headliners:**

26. Select a location to install either the toggle switch or the rocker switch. If the toggle switch is to be used, ½" diameter hole is required. If the rectangular rocker switch is to be used, a .840" x 1.400" rectangular hole is required.
27. Route the red wire from the strobe light to the switch. Cut red wire and install female terminal blade connectors to red wire and connect from strobe light to switch. Insert switch into hole.
28. Note: Wires routing to battery location may be routed down the inside of either front cab frame tube and be covered with protective wire loom. Route the remaining length of red wire, from switch to battery location. Route the black wire from strobe light to the battery location.
29. Attach a 5/16" terminal ring to black wire. Black wire may need to be shortened depending on tractor models and brands. Secure to -12V terminal of battery.
30. Connect fuse link to red wire using the blue butt splice connector. The red wire may also need to be shortened depending on tractor models and brands.
31. Attach 5/16" terminal ring connector to remaining end of fuse link wire. Secure to +12V terminal of battery.
32. Install 2 amp fuse into fuse holder and attach fuse cover to fuse holder.
33. Check strobe light operation by turning the beacon switch on and off.

Revision history:

05-14-18 Amber LED-Strobe Light 3-23416 was 3-18689

Manufactured by:  
  
BOX 70 • LITCHFIELD, MINNESOTA 55355-0070  
(320) 693-3221 Fax: (320) 693-7252  
[www.CPcabs.com](http://www.CPcabs.com)

05-10830  
May 14, 2018