

INSTALLATION INSTRUCTIONS  
John Deere One Series and 20 Series

**COZYcab™**



**A-11859**  
**TEMPERED GLASS DOORS KIT**  
Fits Cab Kit A-11858 for 20 Series tractors  
and  
Cab Kit A-11976 for One Series tractors

## INSTALLATION INSTRUCTIONS John Deere One Series and 20 Series

Read these instructions and identify all components. Please retain these instructions for future reference and parts ordering information. Refer to kit components and Figure 1 for general layout.

Kit Components:	ITEM	QTY	DESCRIPTION	P/N
	1	1	DOOR ASSEMBLY, LH	4-15556
	2	1	DOOR ASSEMBLY, RH	4-15557
	3	1	DOOR MOUNT BRACKET, LH	2-16507
	4	1	DOOR MOUNT BRACKET, RH	2-16508
	5	1	HARDWARE KIT (CONSISTS OF ITEMS 6-11)	4-15558
	6	2	STRIKER STUD, 10 MM	3-18069
	7	2	10MM HEX JAM NUT	3-18070
	8	8	5/16 X 3/4" LONG, TRUSS BUTTON TORX BOLT	3-19340
	9	8	5/16" FLANGE NUT	3-17111
	10	4	BRASS HINGE WASHER	B3-15971
	11	2	BALL STUD FOR GAS SPRING	3-11821

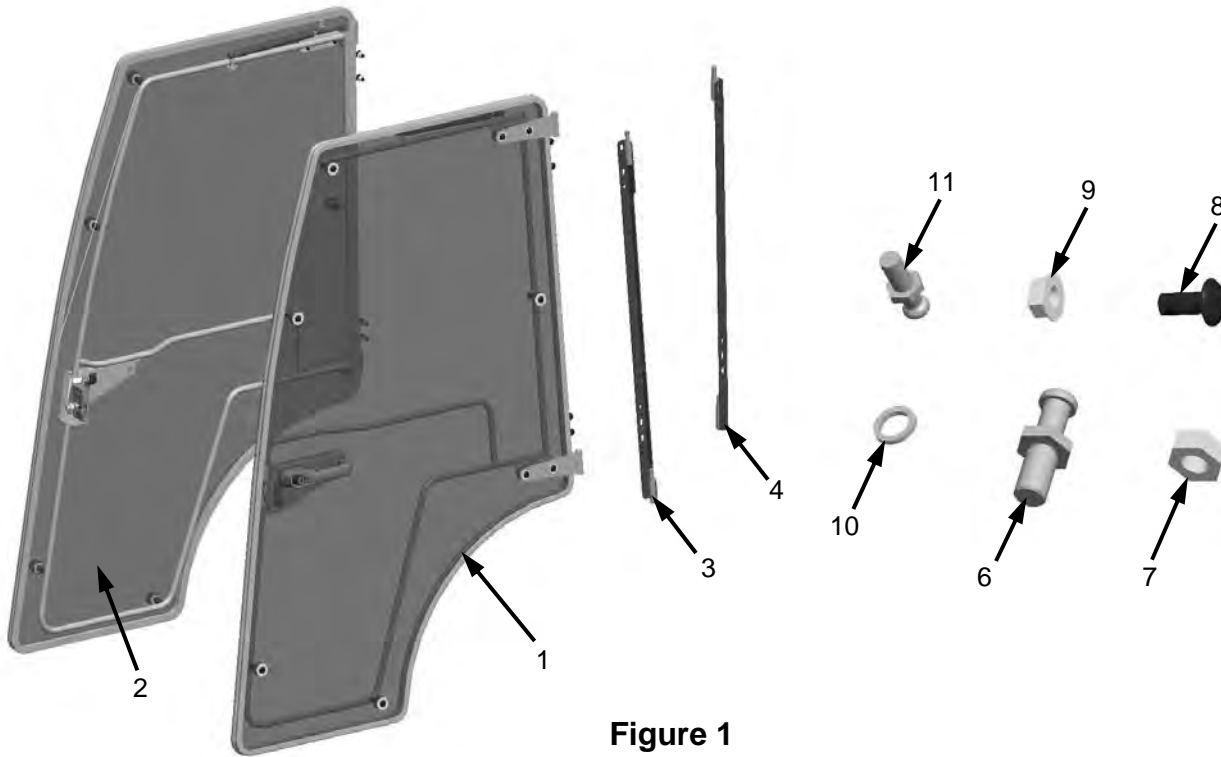

**Figure 1**

## INSTALLATION INSTRUCTIONS John Deere One Series and 20 Series

**Note: Cab kit must be installed prior to installing this kit!**

### Installation of doors:

1. Remove knock-outs from rear cab side panel (**Figure 2**).
2. Secure hinge mount bracket (3 LH) (4 RH) onto rear cab side panel and secure (**Figure 2**):
  - (8) 5/16 x 3/4" long, truss button torx head bolts (8)
  - (8) 5/16" flange nuts (9)
3. Place brass washer (10) onto each hinge pin location (**Figure 2**).
4. Install each door (1 LH) (2 RH) onto corresponding hinge bracket.
5. Install striker stud (6) and jam nut (7) to each LH and RH side frame striker mount (**Figure 3**).
6. Open and close door. Adjust striker and hinge mount brackets for proper alignment.
7. Install ball stud (11) into each side header of cab (**Figure 3**).
8. Remove nylon tie that secures gas spring to door frame tube (**Figure 3**).
9. Connect gas spring end to ball stud (**Figure 3**).

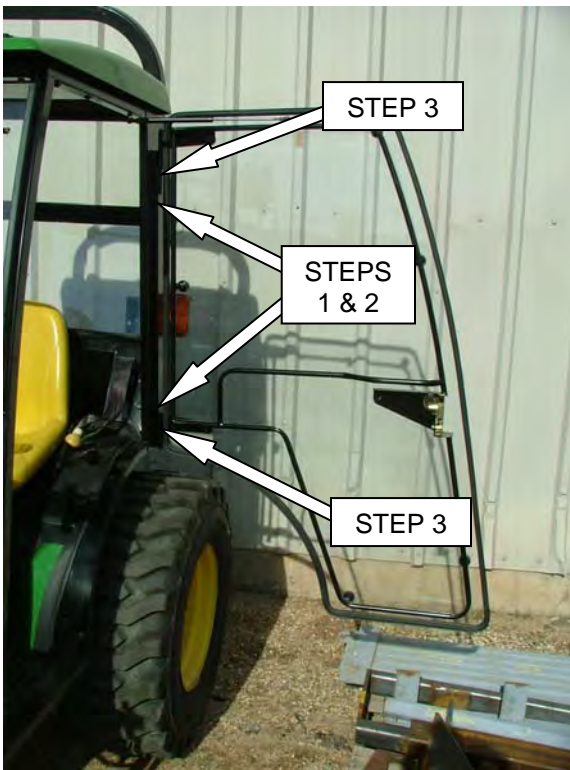

**Figure 2**



**Figure 3**

Installation is now complete. If you have any questions or comments, contact;

 **CUSTOM PRODUCTS** ©2011  
OF LITCHFIELD INC  
PO BOX 70, 1715 S. Sibley Avenue, Litchfield, MN 55355-0070  
Ph: (320) 693-3221 Fax: (320) 693-4833  
[www.CPcabs.com](http://www.CPcabs.com)

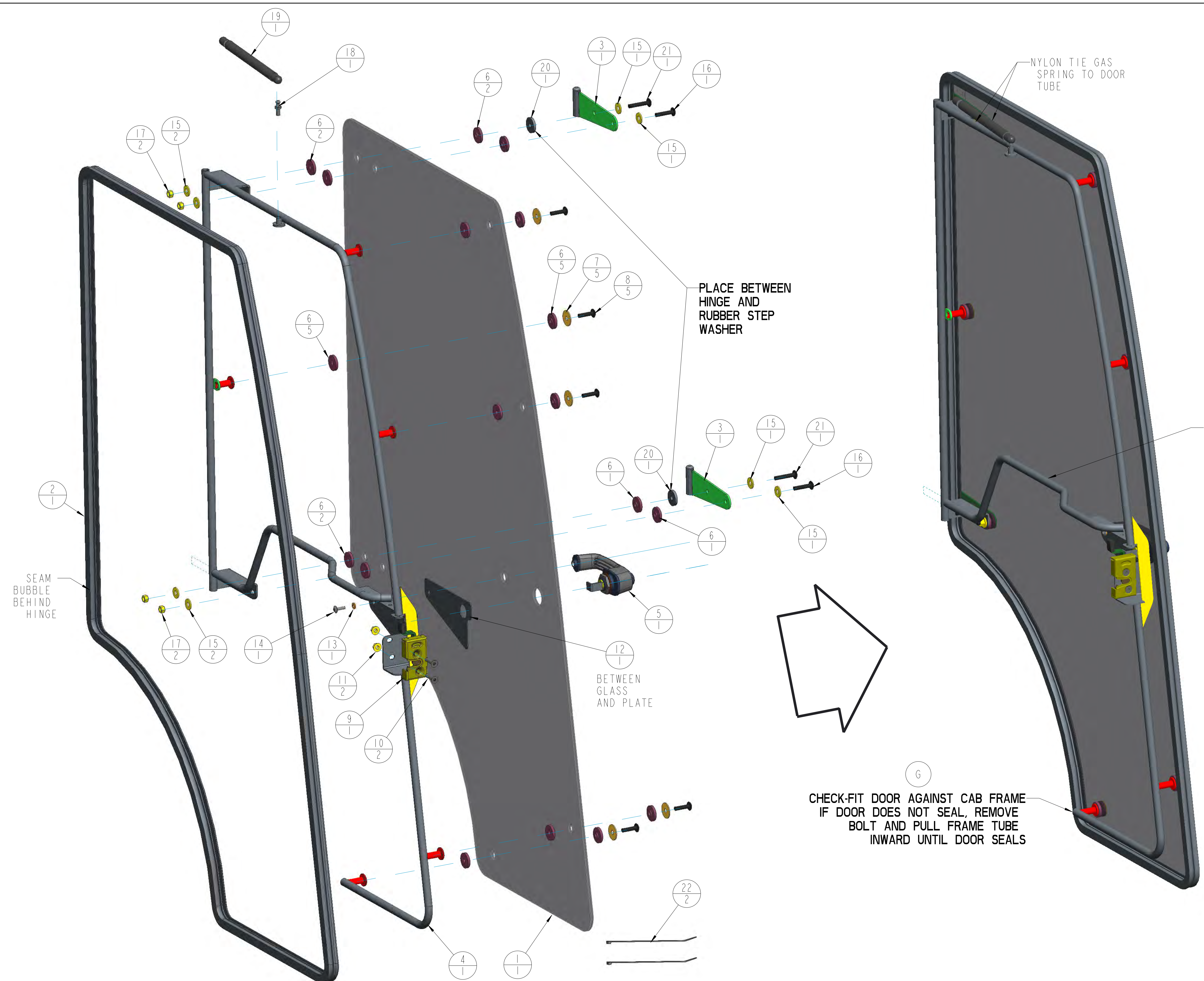

REV	DCR NO.	DESCRIPTION	DRAFTSMAN	DATE
A1	10018	LATCH 3-19308 WAS 3-19309	CAD	12-08-10
A2	10018	3-19432 WAS 3-18324	CAD	12-08-10
B	-	GAS SPRING WAS 3-11929 30 LB	CAD	04-11-11
C	10393	UPDATED 2-16633 FRAME WELDMNT	SRB	11/15/11
D	10803	MOVED BUBBLE SEAM	SLD	12/6/12
E	10883	ADDED RUBBER WASHER 3-15769; BOLT 3-19343 WAS 3-19342	CAD	02/21/13
F	11665	ADDED (2) 3-16629	BSM	02-02-15
G	11721	QTY 3-15769 WAS 1 & QTY 3-19343 WAS (1); ADDED NOTE TO BEND TUBE IF NEEDED	CAD	03-06-15

ITEM #	DESCRIPTION	QTY	
1	3-19542_DOOR_PANEL	1	
2	3-19324_BUB_RUB_169_LG	1	
3	2-16504_HINGE_DOOR_WELDMNT	2	
4	2-16633_DOOR_FRAME_LH	1	
5	3-19307_HANDLE_EXTERI_SW0001	1	
6	3-16217_GLASS_WASHER	18	
7	3-18187_31_FENDER_WASHER	5	
8	3-18324_313_18_NC_125_TH_TORX	5	
A1	9	3-19308_LATCH_DLP_615100-2_SW	1
10	3-18453_MSCR_312-18X125_FH_TORX	2	
11	3-17111_SER_FLNG_NUT_312	2	
12	3-19325_FOAM_SPACER_DOOR	1	
13	3-10076_250_LOCK_WASHER	1	
14	3-18312_MSCR_M6X20_TH_TORX	1	
15	3-10085_3125_WASHER	8	
A2	16	3-19342_MSCR_313X150_TRUSS_TORX	2
17	3-10072_3125_NYLOCK	4	
B	18	3-11821_BALL_STUD	1
G	19	3-13024_GAS_SPRING_6IN	1
E	20	3-15769_RUB_WASHER_371DX125OD	2
21	3-19343_MSCR_313X175_TRUSS_TORX	2	
B	22	3-16629_WIRE_TIE	2

SCALE 0.250

REF RH MIRROR ASM 4-15557

THIS DOCUMENT CONTAINS CONFIDENTIAL INFORMATION AND IS THE PROPERTY OF CUSTOM PRODUCTS OF LITCHFIELD, INC. AND MAY NOT BE COPIED, REPRODUCED OR DISCLOSED IN ANY MANNER WITHOUT EXPRESSED WRITTEN CONSENT FROM CUSTOM PRODUCTS OF LITCHFIELD, INC.

TOLERANCES UNLESS NOTED OTHERWISE	CUSTOMER NAME & MOD NO. JD ONE AND 20 SERIES	MATL SPEC.
	CUSTOM PRODUCTS 1715 SOUTH SIBLEY AVE LITCHFIELD, MN 55355	
X ± .09 XX ± .06 XXX ± .03 HOLE SIZE /05/100 ANGLE ± 5°	TITLE DOOR ASSEMBLY LH	DRWG NO. 4-15556 1 of 1
	DRWG SIZE D	REV LEVEL G
	DATE 05-27-10	

NAME: CAD2 OBJECT: 4-15556 DATE: 06-Mar-15 13:46:56

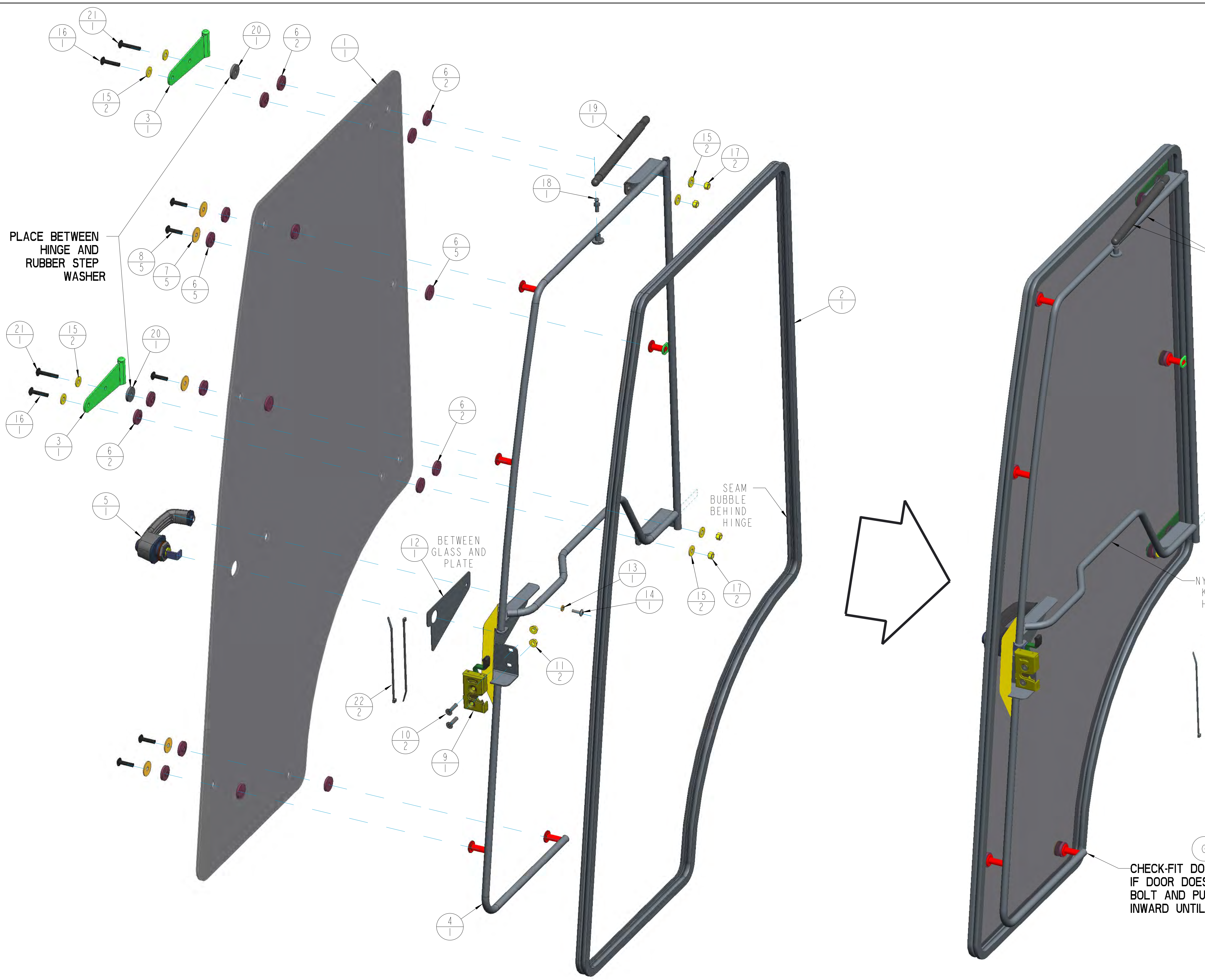

REV	DCR NO.	DESCRIPTION	DRAFTSMAN	DATE
A1	10018	LATCH 3-19309 WAS 3-19308	CAD	12-08-10
A2	10018	BOLT 3-19432 WAS 3-18324	CAD	12-08-10
B	-	GAS SPRING WAS 3-11929 30 LB	CAD	04-11-11
C	10393	UPDATED WELDMENT 2-16634	SRB	11/15/11
D	10802	MOVED BUBBLE SEAM	SLD	12/6/12
E	10883	ADDED ITEM 3-15769; BOLT 3-19343 WAS 3-19342	CAD	02/21/13
F	11665	ADDED (2) 3-16629	BSM	2/2/15
G	11721	QTY OF 3-15769 WAS 1; QTY OF 3-19343 WAS 1; ADDED NOT TO BEND IF NEEDED	CAD	03-06-15

ITEM #	DESCRIPTION	QTY	
1	3-19542_DOOR_PANEL_MIR	1	
2	3-19324_BUB_RUB_MIR	1	
3	2-16504_HINGE_DOOR_WELD_TEMP	2	
4	2-16634_DOOR_FRAME_RH_MIR	1	
5	3-19307_HANDLE_EXTERI_SW_REF	1	
6	3-16217_GLASS_WASHER_MIR	18	
7	3-18187_31_FENDER_WASHER_MIR	5	
8	3-18324_313_18_NC_125_TH_TX_REF	5	
A1	9	3-19309_LATCH_DLP_615100-1	1
10	3-18453_MSCR_312-18X125_FH_MIR	2	
11	3-17111_SER_FLNG_NUT_312_MIR	2	
12	3-19325_FOAM_SPACER_DOOR_REF	1	
13	3-10076_250_LOCK_WASHER_MIR	1	
14	3-18312_MSCR_M6X20_TH_TORX_MIR	1	
15	3-10085_3125_WASHER_MIR	8	
A2	16	3-19342_MSCR_313X150_TRUSS_TORX	2
17	3-10072_3125_NYLOCK_MIR	4	
B	18	3-11821_BALL_STUD_MIR	1
19	3-13024_GAS_SPRING_6IN	1	
E	20	3-15769_RUB_WASHER_371DX1250D	2
G	21	3-19343_MSCR_313X175_TRUSS_TORX	2
B	22	3-16629_WIRE_TIE	2

CHECK-FIT DOOR AGAINST CAB FRAME IF DOOR DOES NOT SEAL, REMOVE BOLT AND PULL FRAME TUBE INWARD UNTIL DOOR SEALS

REF RH MIRROR ASM 4-15556

TOLERANCES UNLESS NOTED OTHERWISE		CUSTOMER NAME & MOD NO. JD ONE AND 20 SERIES		MATERIAL SPEC.	
X ± .09		CUSTOM PRODUCTS		1715 SOUTH SIBLEY AVE LITCHFIELD, MN 55355	
.XX ± .06		TITLE		DRAWING NO.	
.XXX ± .03		DOOR ASSEMBLY RH		4-15557	
HOLE SIZE		DRAWN		REV LEVEL	
.06/+.00		CAD		1 of 1	
ANGLE ± 5°		DATE		G	
		05-27-10			

SCALE 0.250