



A-12045 AMBER STROBE LIGHT KIT

Note: This kit requires a minimum current draw of 1 amp at 12 VDC. Do not exceed the machine's available alternator capacity. If you do not know how much current is available, contact your dealer or manufacturer of this machine, prior to installing this kit. This kit is for use in cabs that have a factory installed overhead switch console. The cab and overhead switch console are supplied with a main feed breaker/relay wire harness and 6-slot fuse block with ground terminals.

Before you begin, read these instructions and identify all components (Figure 1). Please retain these instructions for future reference and parts ordering information.

Kit Components:	ITEM	QTY	DESCRIPTION	PART NO.
	1	1	BEACON MOUNT BRACKET	2-16999
	2	1	FOAM SEAL RING FOR STROBE LIGHT	3-18691
	3	1	AMBER STROBE LIGHT 12VDC	3-18689
	4	3	No. 8 x 1.00" LONG BUTTON HEAD SCREW	3-18808
	5	3	No. 8 HEX NYLOCK NUT	3-18860
	6	2	BOLT, BUTTON TRUSS, 5/16 x 3/4" LONG	3-19340
	7	2	FLANGE NUT, 5/16"	3-17111
	8	1	WIRE HARNESS, BEACON	3-19685
	9	1	WIRE HARNESS, SWITCH TO FUSE BLOCK	3-19686
	10	1	ROCKER SWITCH BODY ON-OFF-LIT	3-18189
	11	1	ROCKER SWITCH ACTUATOR W/ BEACON IMP	3-18513
	12	1	FUSE, 2 AMP ATO/ATC BLADE TYPE	3-16582
	13	8	NYLON TIE	3-16629
	14	6	NYLON TIE MOUNT	3-17517
	15	1	WIRE LOOM DUCT, 3/8" x 12" LONG	3-10704

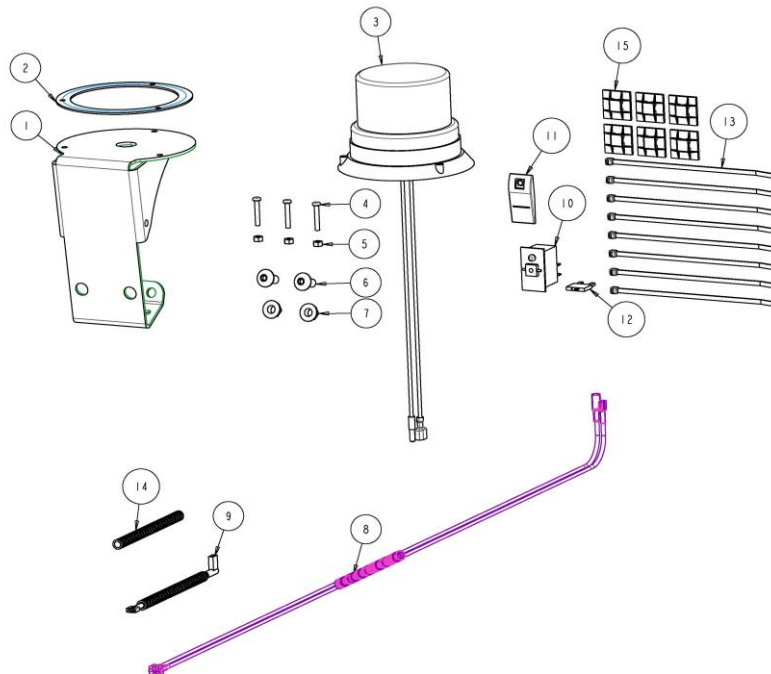

Figure 1

STROBE LIGHT INSTALLATION:

1. Make sure machine's ignition key is turned off. Remove key.
2. Place strobe light (Item 2) with foam seal (Item 3) onto beacon mount bracket (Item 1) and route wires through center hole in bracket (**Figure 2**).
3. Secure strobe light and foam seal ring to bracket using (3) No. 8 x 1.00" long button head screws (Item 4), and (3) No.8 nylock nuts (Item 5) (**Figure 2**).

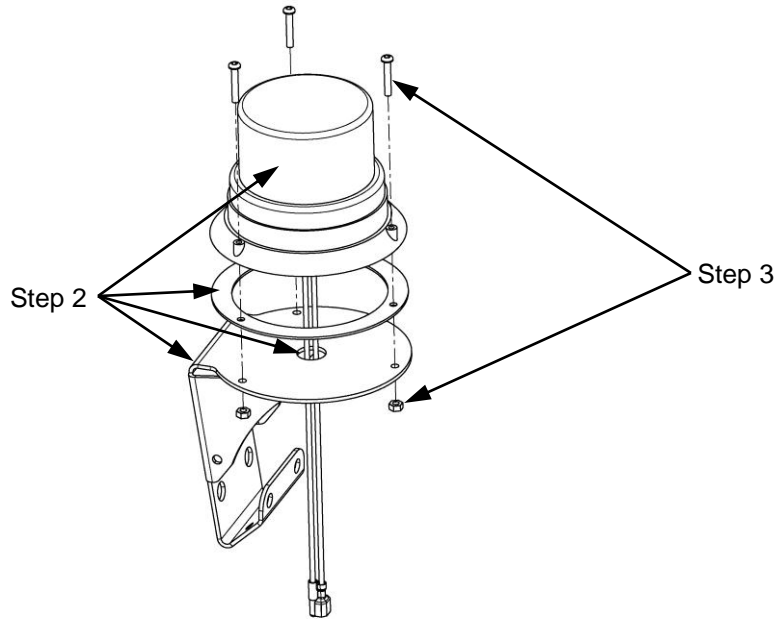

Figure 2

4. Remove the (3) rear roof bolts. Insert a block to raise the back of the roof, 2 to 3".
5. Locate and remove the (2) 3/8" hole plugs located above the upper rear window (**Figure 3**).
6. Secure mount bracket using (2) 5/16" x 3/4" long button head bolts (Item 6) and (2) 5/16" flange nuts (Item 7) (**Figure 3**).

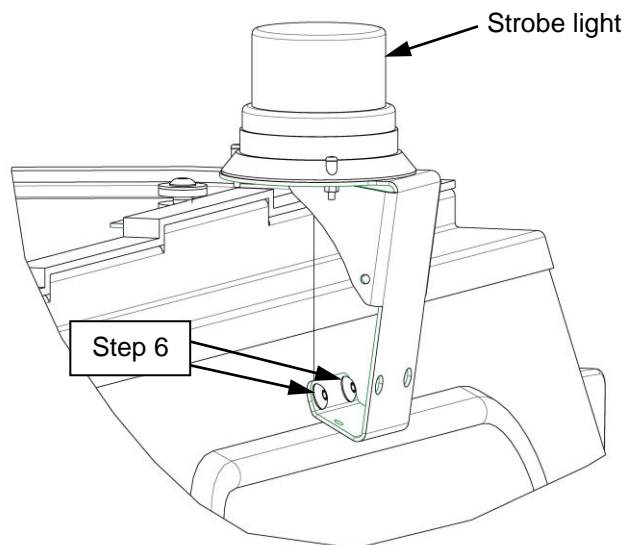

Figure 3
(Roof not shown)

7. Connect beacon wire harness 3-19685 (Item 10) to strobe light.
8. Route opposite end of beacon wire harness, from the strobe light, between the roof and rear cross member, along either side of cab's upper frame channel, forward to the overhead switch panel location.
9. Remove bolts that secure the switch panel to the cab. Allow switch panel to tip down.
10. Select a location in switch panel for the rocker switch. Remove rectangular knockout. Important! Do not install rocker switch until step 16!
11. Route red wire of beacon wire harness, through the rocker switch hole and connect to rocker switch terminal 3 (Figures 4 & 6).
12. Connect black wire of beacon wire harness to fuse block (-12VDC) grounding terminal (Figure 4 & 5).
13. Remove fuse block access cover from switch panel.
14. Locate the shorter fuse block to switch wire harness 3-19686 (Item 9). Connect 90 degree connector of wire to empty fuse terminal location (Figure 5).
15. Route straight connector end of wire harness through switch knockout hole and connect to rocker switch terminal 2 (Figures 4 & 6).
16. Attach switch actuator (Item 11) to rocker switch (Item 10) then install switch into knockout hole in switch panel (Figure 4).
17. Install 2 amp fuse into fuse block location selected in Step 14 (Figures 4 & 5).

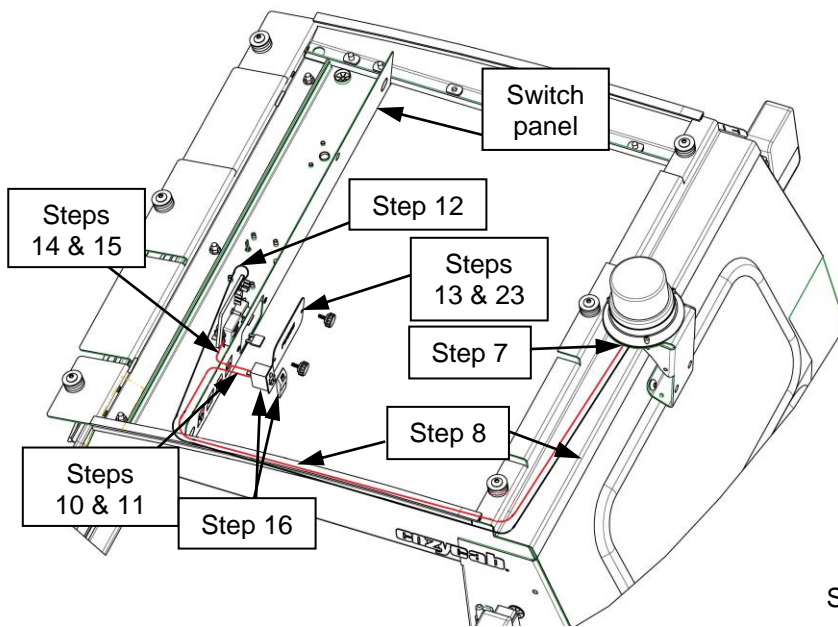

Figure 4
(Roof not shown)

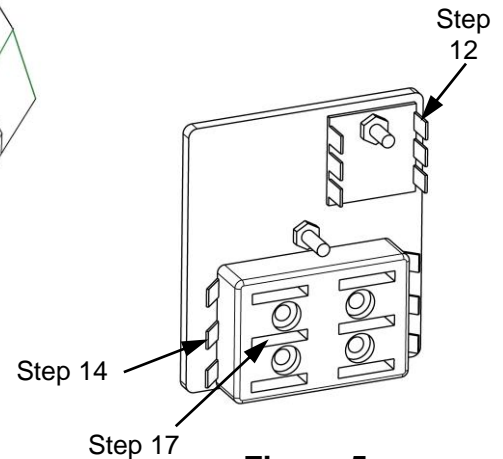
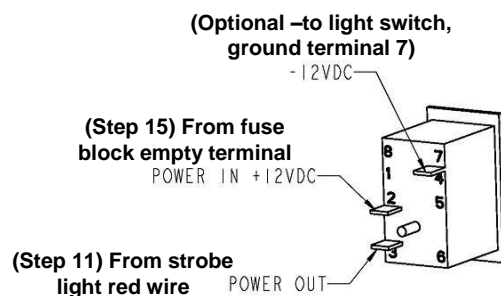

Figure 5
(Fuse block)



ROCKER SWITCH 3-18189
20A MAX AT 12VDC
TYPICAL SWITCH WIRING

Figure 6

18. Install protective wire loom (Item 15) over beacon kit wires.
19. Remove spacer block, lower roof and re-secure back of roof.
20. Turn tractor's ignition key "On" and check strobe light operation by turning the beacon rocker switch, on and off. Strobe should also turn off when tractor's ignition key is turned off.
21. Secure wire harness using nylon tie mounts (Item 14) on inside header locations where wire harness was run.
22. Re-install switch panel to cab.
23. Secure fuse access cover panel to switch panel.



PO BOX 70, 1715 S. Sibley Avenue, Litchfield, MN 55355-0070
Ph: (320) 693-3221 Fax: (320) 693-4833
www.CPcabs.com

05-11392
November 21, 2012