



**A-12093**  
**JDX 2014 HEATER KIT**  
**With Gas Engine Connection Fittings**  
**2014 and Newer ROPS Cabs A-12098**  
**(Kit A-12092, Diesel Engine Connection Fittings are sold separately for diesel models)**



**Note:** This kit requires a minimum current draw of 7 amps at 12 VDC. Do not exceed the machine's available alternator capacity. If you do not know how much current is available, contact your dealer or manufacturer of this machine, prior to installing this kit. This kit is for use in cabs that have a factory installed overhead switch console. The cab and overhead switch console are supplied with a main feed breaker/relay wire harness and an 8-slot fuse block with separate ground bar terminals.

Before you begin, read these instructions and identify all components. Please retain these instructions for future reference and parts ordering information.

**Note:** Cab should be installed prior to installing heater kit. Refer to kit components and Figure 1 for general layout. **Kit A-12092, diesel engine connection fittings is sold separately for diesel models.**

**John Deere X, Signature Series 2014 and newer specifications;**

MODEL	FUEL	HP	CC'S	TRANS	ALTERNATOR AMPS	SOURCE CONNECTION	RETURN CONNECTION
X710	GAS OHV	22	745	2WD	20	1/2" BYPASS HOSE	1/2" BYPASS HOSE
X730	GAS EFI	25.5	745	2WD	20	1/2" BYPASS HOSE	1/2" BYPASS HOSE
X734	GAS EFI	25.5	745	2WD AWS	20	1/2" BYPASS HOSE	1/2" BYPASS HOSE
X738	GAS EFI	25.5	745	4WD	20	1/2" BYPASS HOSE	1/2" BYPASS HOSE
X739	GAS EFI	25.5	745	4WD AWS	20	1/2" BYPASS HOSE	1/2" BYPASS HOSE
X750	DIESEL OHV	24	993	2WD	40	M16 SENSOR PORT	LOWER RADIATOR HOSE Y
X754	DIESEL OHV	24	993	2WD AWS	40	M16 SENSOR PORT	LOWER RADIATOR HOSE Y
X758	DIESEL OHV	24	993	4WD	40	M16 SENSOR PORT	LOWER RADIATOR HOSE Y

## MOUNTING INSTRUCTIONS

Kit Components:	ITEM	QTY	PART No.	DESCRIPTION
	1	2	3-10730	GROMMET, 1.37"
	2	5	3-10858	HOSE CLAMP, No. 10
	3	1	3-11172	HEATER HOSE, 5/8" x 48" LONG
	4	1	3-11172	HEATER HOSE, 5/8" x 48" LONG
	5	3	3-11255	CLAMP, DUAL HOSE P
	6	1	3-12091	GROMMET, .75"
	8	1	3-14214	HEATER HOSE, 1/2" x 12" LONG
	9	1	3-16057	FUSE, 10 AMP
	11	8	3-16629	NYLON TIE, BLACK
	12	2	3-16693	FITTING, REDUCER, .50" TO .62"
	14	1	3-19155	HOSE COVER FABRIC
	15	6	3-19340	BOLT, TORX HEAD, 5/16" x 1.00" LONG
	16	6	3-20329	NUT, FLANGE, NYLOC, 5/16"
	17	1	3-20412	WIRE HARNESS, HEATER UNIT, JDX MY14
	18	1	4-16071	HEATER UNIT, JDX MY14
	19	1	05-11545	MOUNTING INSTRUCTIONS (NOT SHOWN)

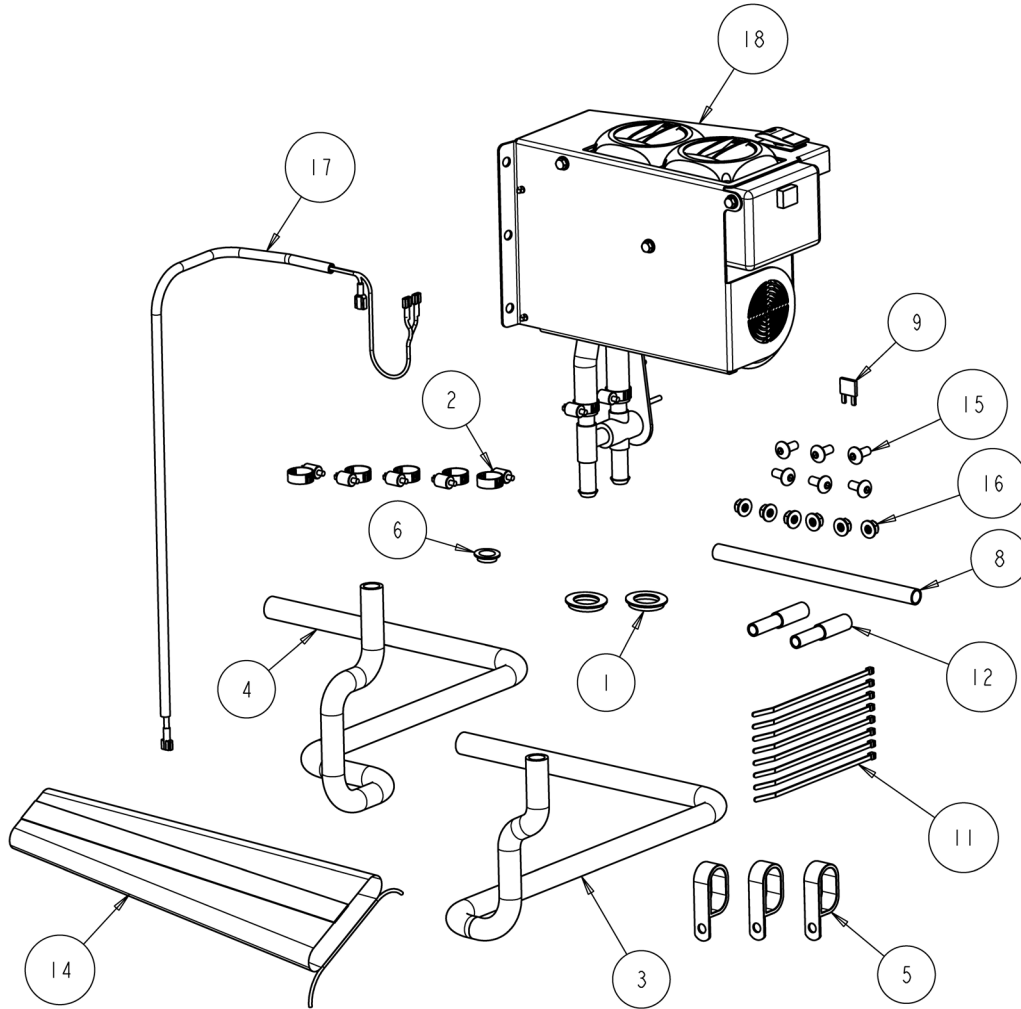

**Figure 1**  
**(General Layout)**

## MOUNTING INSTRUCTIONS

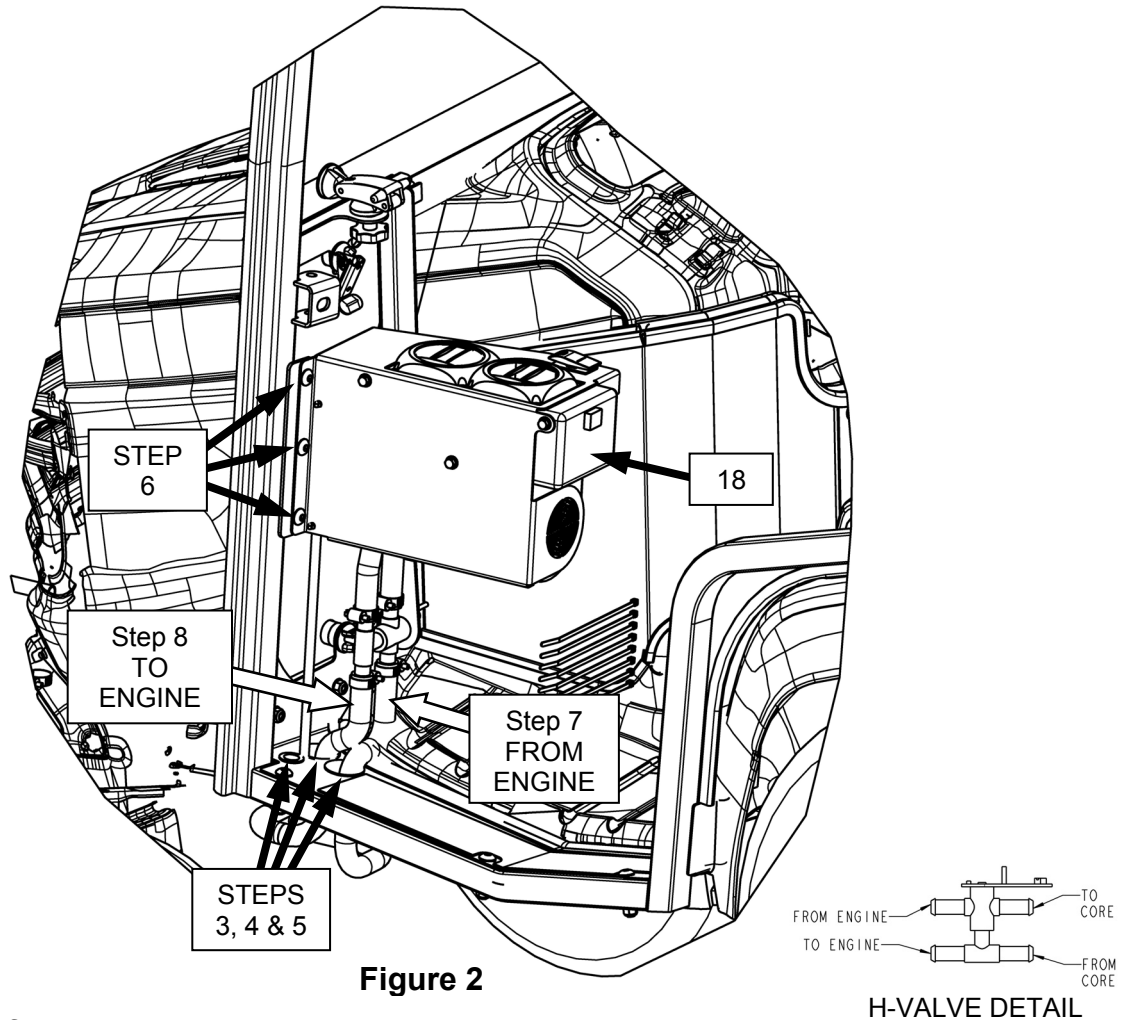

Figure 2

H-VALVE DETAIL

### Preparation of Tractor;

1. Park tractor on level surface and turn ignition key off.
2. Allow engine to cool. Drain coolant from radiator. Remove front LH lower cab window.

### Mounting the heater unit;

3. Remove (2) 1.37" hole plugs and (1) 3/4" hole plug, located on LH cab deck plate (**Figure 2**).
4. Install (2) 1.37" grommets into 1.37" hole on LH cab deck plate (**Figure 2**).
5. Install (1) 3/4" grommet into 3/4" hole on LH cab deck plate (**Figure 2**).
6. Secure heater unit (18) to mount bracket located on the front left cab tube. Secure heater assembly to location using (**Figure 2**);
  - (3) Bolt, button torx, 5/16 x 1.00" long (15)
  - (3) Nut, hex nylock flange, 5/16" (16)
7. From the bottom of the cab, route one piece of 5/8" heater hose, 48" long (3) through the inner grommet/hole and insert onto inner nipple of H-valve. Secure using a No. 10 hose clamp (2) (**Figure 2**).
8. From the bottom of the cab, route one piece of 5/8" heater hose, 48" long (4) through the outer grommet/hole and insert onto outer H-valve nipple. Secure using a No. 10 hose clamp (2) (**Figure 2**).
9. Route both hoses from front cab mount tube, to RH side of engine and up to thermostat location.  
**Note: Avoid routing hoses near hot or moving components.**

## MOUNTING INSTRUCTIONS

### **FOR CONNECTING TO GAS ENGINES, FOLLOW STEPS 10-13** (For Diesel engines skip to step 14);

10. Locate the 1/2" bypass hose that is located behind the engine's thermostat area (**Figure 3**). Disconnect the lower end of 1/2" bypass hose from the engine's bypass nipple. Loosen other end of 1/2" bypass hose and rotate hose slightly to allow connection in steps to follow.
11. Connect 1/2" x 12" long heater hose (8) to bypass nipple in **Step 10** using a No. 10 hose clamp (2).
12. Locate the heater hose from the heater kit's H-valve inner nipple from **Step 7**. Connect to the 1/2" x 12" long heater hose (8) using a 1/2" x 5/8" hose reducer fitting (12) and a No. 10 hose clamp (2). Shorten 5/8" heater hose if needed.
13. Connect remaining 5/8" x 48" long heater hose from the remaining H-Valve outer nipple, to the bypass hose using reducer fitting (12). Shorten hose if needed. Secure using a No. 10 hose clamp (2). This hose will be the return route from the H-valve (and the heater) to the engine (**Figure 3**).

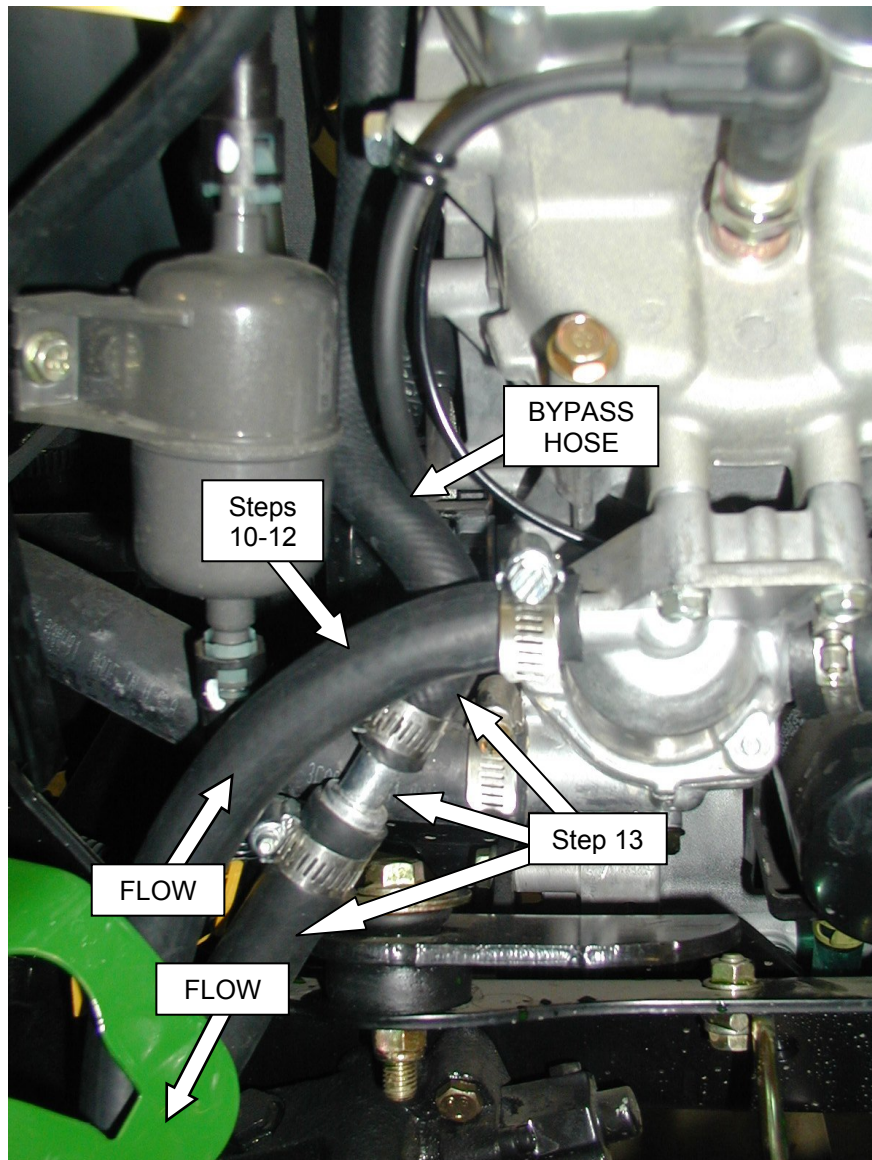

**Figure 3**  
**(Gas Engine Shown)**

## MOUNTING INSTRUCTIONS

**FOR CONNECTING TO DIESEL ENGINES, FOLLOW STEPS 14-23 (DIESEL ENGINE CONNECTION KIT A-12092 is sold separately) For gas models, skip to Step 24;**

### A-12092 Diesel Engine connection components (Figure 4);

ITEM	QTY	PART No.	DESCRIPTION
A	2	3-10858	HOSE CLAMP, No. 10
B	1	3-12119	FITTING, BRASS, 3/8" NPT TP 5/8" HOSE BARB
C	2	3-13442	HOSE CLAMP, LARGE
D	1	3-18259	NUT, HEX JAM, M16
E	1	3-18260	WASHER, BRASS, M16
F	1	3-20137	Y-FITTING, 5/8X1.12X 1.12
G	1	3-20284	FITTING, ALUMINUM, M16 JAM TYPE

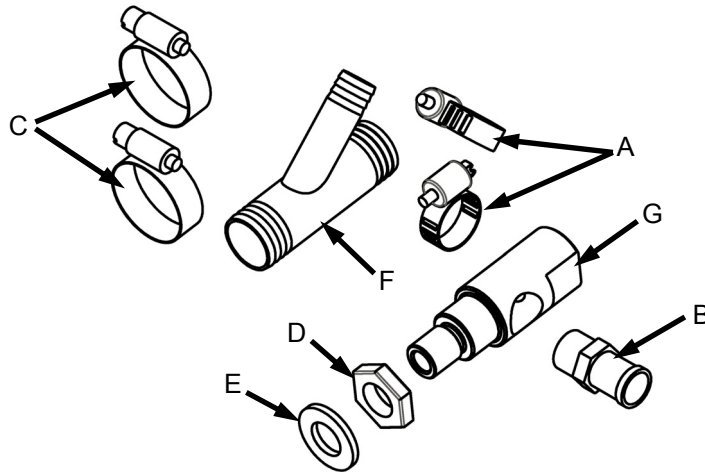

**Figure 4**  
**(A-12092 Diesel Engine Connection Components Kit)**

14. Locate temperature sensor near the engine's thermostat area.
15. Unplug the temperature sensor wire and remove the sensor and seal from the thermostat area. Set aside for re-installation in step 18 (**Figure 5**).
16. Install the aluminum fitting (G) into the thermostat housing with brass washer (E) and M16 jam nut (D). Orientate the aluminum fitting (G) so that the side port is accessible (**Figure 5**) for brass fitting (B) installation. Use pipe seal thread tape or liquid pipe seal compound on all threaded fittings.
17. Using thread seal tape, install the 3/8" NPT x 5/8" brass hose fitting (B) into the side port of the aluminum fitting (13) (**Figure 5**).
18. Re-install the temperature sensor into the end port of the aluminum fitting (G) (**Figure 5**).
19. Re-connect the sensor wire to temperature sensor (**Figure 5**).
20. Route 5/8" x 48" long heater hose (3) from the H-valve **inner** nipple to the brass fitting (B), installed in Step 17. Trim excess hose if present. Secure hose using a No. 10 hose clamp (A) (**Figure 5**).
21. Locate and remove 1/2" section out of the lower radiator hose for Y-fitting (F) installation (**Figure 5**).
22. Install Y-fitting (F) into the lower radiator hose and secure using two large hose clamps (C). **The Y-Fitting (F) MUST BE ORIENTATED CORRECTLY!** (**Figure 5**).
23. Route the remaining 5/8" x 48" long heater hose (4) from the outer H-valve nipple to the 5/8" Y-fitting nipple (F). Insert hose onto nipple and secure using a No. 10 hose clamp (A) (**Figure 5**). Trim excess hose if present.

## MOUNTING INSTRUCTIONS

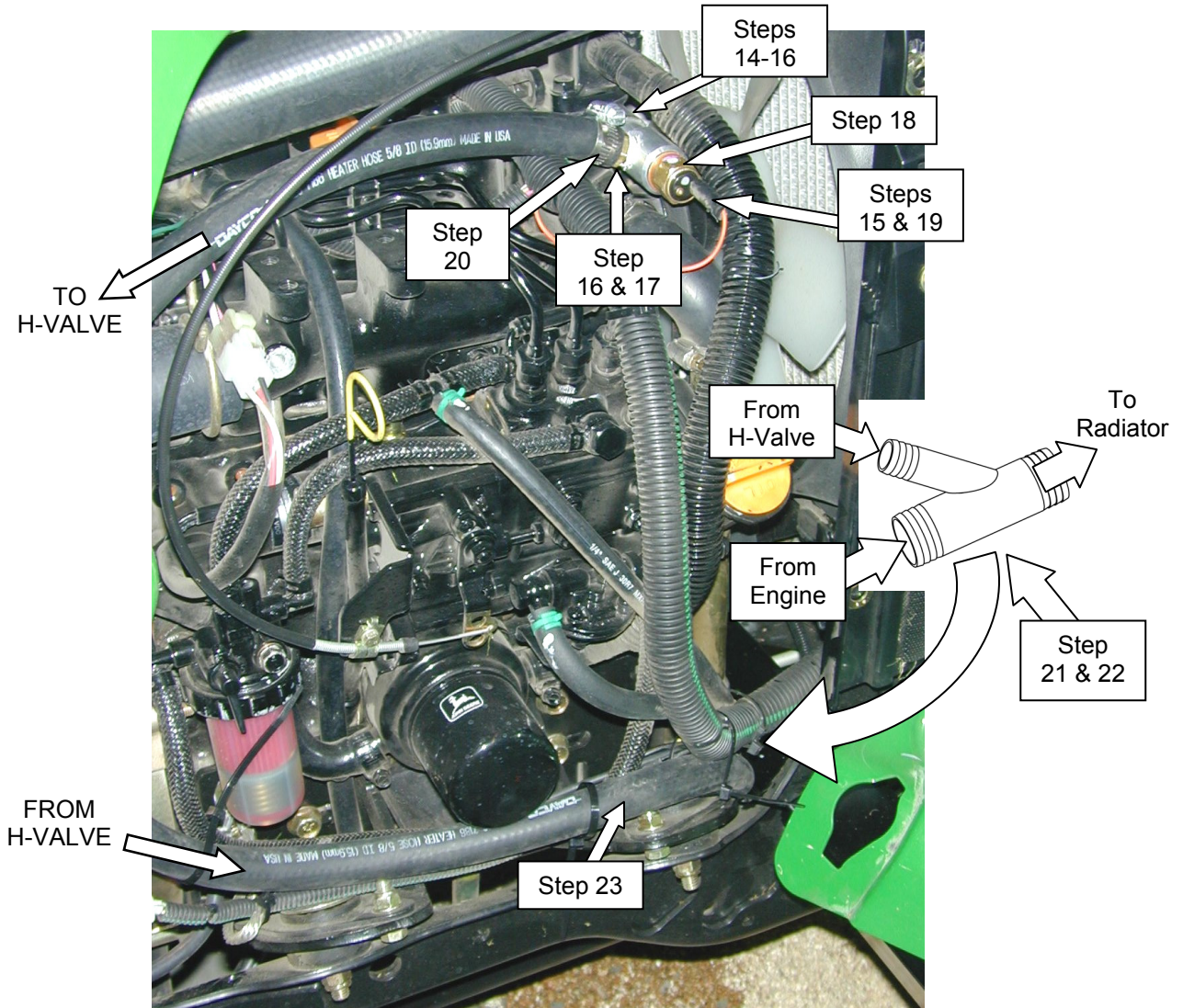

**Figure 5  
(Diesel Engine Shown)**

### Connecting power to headliner;

24. Remove two front bolts and loosen two rear bolts that secure the overhead switch panel to the cab. Allow switch panel to tip down.
25. Remove fuse access cover from overhead switch panel.
26. Locate heater to fuse block wire harness (17). From inside of cab, route wire harness from heater, up LH cab frame tube to overhead switch panel fuse block location (**Figure 6**).
27. Connect wire harness (17) to heater unit (18). Red wires 2 & 5 of wire harness to heater unit switch terminals 2 & 5. Connect black wire of wire harness to heater unit black wire.
28. Connect opposite end of wire harness (17) black wire labeled -12V of wire harness to a fuse block grounding terminal.
29. Connect opposite end of wire harness (17) red wire labeled +12V of wire harness to an empty fuse block terminal.
30. Install 10 amp fuse (9) into location selected in Step 27.

### Completing Installation;

31. Re-fill the radiator.
32. Start tractor and allow engine to run at LO idle and warm up.
33. Turn heater switch on and off to verify proper fan operation.
34. Activate the H-valve by rotating the lever up and down, several times.

05-11545  
April 22, 2014

## MOUNTING INSTRUCTIONS

35. Shut off engine and check coolant.
36. If heat does not emit from heater, repeat steps 32-35, until air is properly purged from system.
37. Install protective heater hose cover fabric (14) to cover heater hoses at the valve location (**Figure 6**).
38. Cut the protective heater hose cover to allow access to the H-valve lever (**Figure 6**).
39. Re-install overhead panel and fuse access cover.

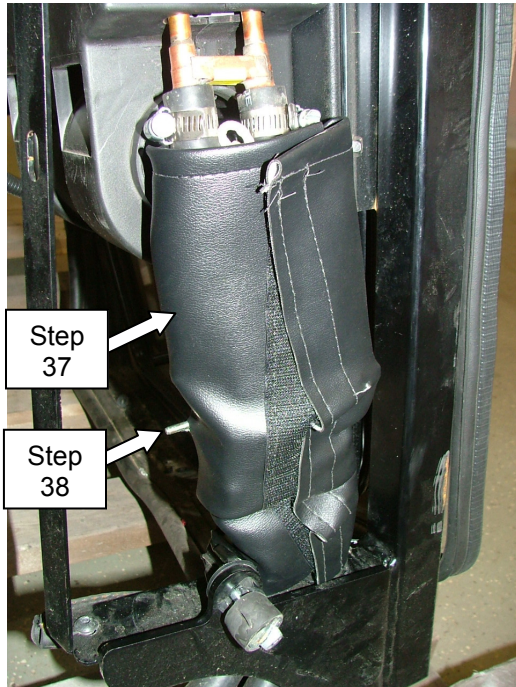

**Figure 6**

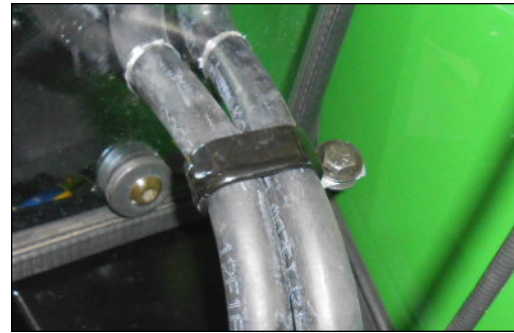

**Figure 7**



**Figure 8**

### Securing heater hoses;

40. Measure 4 inches from front window and secure heater hoses together using (**Figure 7**);
  - (1) Double P-clamp (5)
  - (1) 5/16" x 1.00" long bolt (15)
  - (1) 5/16" hex flange nylock nut (16)
41. Secure remaining locations of heater hoses together and to frame use existing holes already in the frame. Secure to frame using;
  - (2) Double P-clamp (5)
  - (2) 5/16" x 1.00" long bolt (15)
  - (2) 5/16" hex flange nut (16)
42. Secure loose wires and hoses using nylon ties supplied with kit. **Do not secure wires or hoses to high pressure fuel lines, hot surfaces or moving components.**

Note: H-valve lever should be in the "OFF" position when heat is not needed. If overhead panel is wired correctly, the heater fan should turn off when ignition key is turned off.



PO BOX 70, 1715 S. Sibley Avenue, Litchfield, MN 55355-0070  
Ph: (320) 693-3221 Fax: (320) 693-7252  
www.800cabline.com

05-11545  
April 22, 2014