



## A-11638 EZ CAB HEADLINER KIT WITH FUSE BLOCK, DOME LIGHT AND WIRE HARNESSSES

**Note:** Do not exceed the machine's available alternator capacity. If you do not know how much current is available, contact your dealer or manufacturer of this machine, prior to installing this kit or options that require additional power.

### Kit Components:

ITEM	QTY	PART NO.	DESCRIPTION
1	1	4-15331	HEADLINER ASSEMBLY
2	1	05-10804	MOUNTING INSTRUCTIONS FOR A-11638
3	1	3-19280	MAIN WIRE HARNESS
4	1	3-19281	SWITCHES TO ACCESSORIES WIRE HARNESS
5	1	3-19282	FUSE BLOCK TO SWITCHES WIRE HARNESS

**Note:** If optional accessories such as radio or ventilation fans are to be installed, do so now, prior to securing headliner into cab. Refer to mounting instructions supplied in those kits.

### Installing Main Wire Harnesses:

1. Place headliner inside allowing it to hang from cab frame and rear flanges. See figure 1.
2. Route fuse block end of main power feed wire harness 3-19280 from the engine's battery area, up the inside left front cab frame tube.
3. Connect red wire with ¼" terminal ring to the headliner main fuse block terminal stud.
4. Connect black wire with ¼" terminal ring to a ¼" grounding stud that secures fuse block to headliner.
5. Locate control-engine running wire (Power to wire when tractor's ignition key is turned "On"). Using the blue Tee-Tap terminal splice, place Tee-Tap over wire and secure to blue wire from harness with male terminal connector. This connection will energize the relay to allow power up to the headliner fuse block.
6. Verify that the battery end of main wire harness is long enough to reach battery. Some installers may elect to connect to starter area instead. **Do not connect battery at this time.**

**Note:** If no additional accessories are installed, skip steps 7 and 8. Place and secure wire harnesses inside of headliner in case accessories are to be added at a future time.

7. Refer to drawing 3-19282 for connecting wire harness from fuse block to switches.
8. Refer to drawing 3-19281 for connecting wire harness from switches to accessories.
9. Once accessories have been installed, connect main wire harness to battery.
10. Turn (Key) power on and check operation of all accessories.
11. Turn (Key) power off.

### Headliner Installation:

12. If roof is already installed, remove the (4) front 5/16" x 2.50" long button head bolts that secures the roof to each side frame on as shown in Figure 2.
13. Tip-rotate headliner upward to mounting location as shown in Figure 1.
14. (Re)-Install the (4) 5/16" x 2.50" long button head bolts as shown in Figure 2.
15. Turn power (Key) on and verify that all accessories work properly.

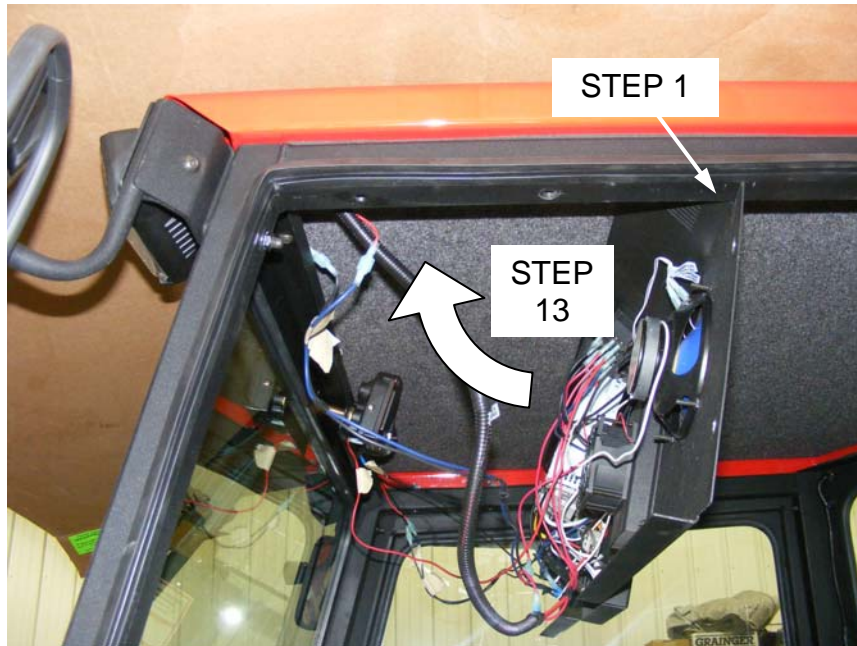

Figure 1

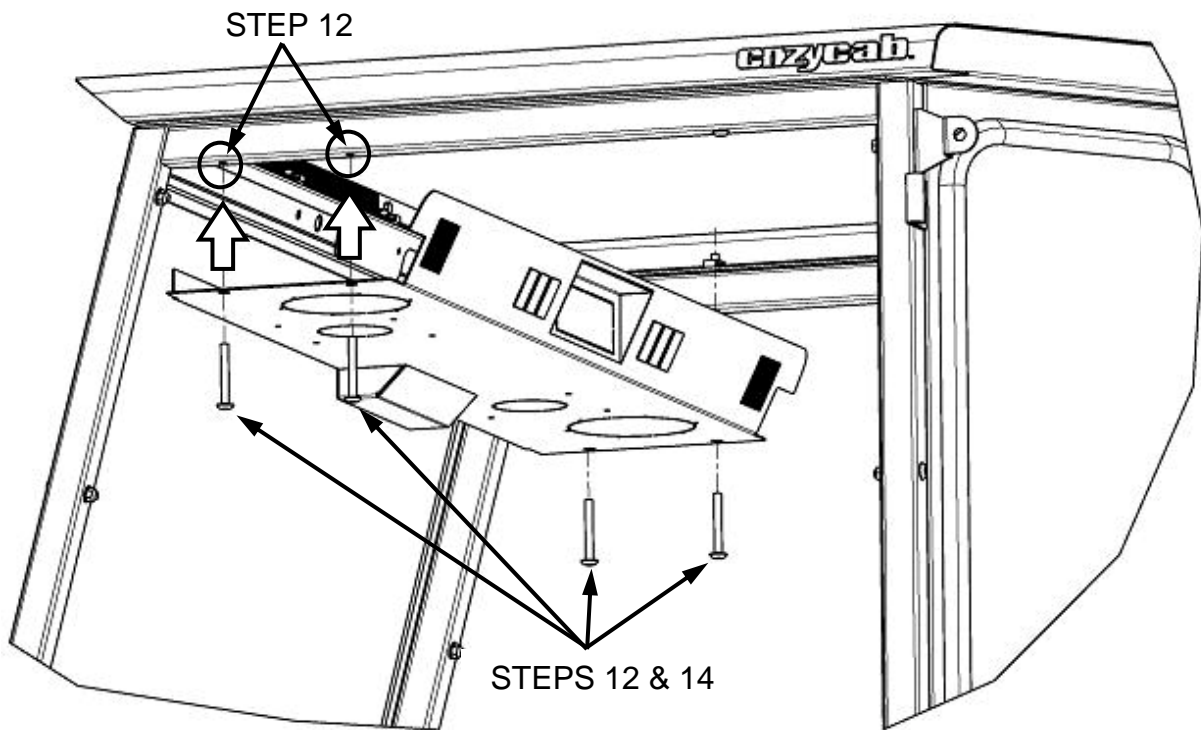

Figure 2

Manufactured by:



BOX 70 • LITCHFIELD, MINNESOTA 55355-0070

(320) 693-3221 Fax: (320) 693-7252

[www.800cabline.com](http://www.800cabline.com)

REV.	DCR NO.	DESCRIPTION	DRAFTSMAN	DATE
-	-	DESIGN RELEASE	-	02-02-09

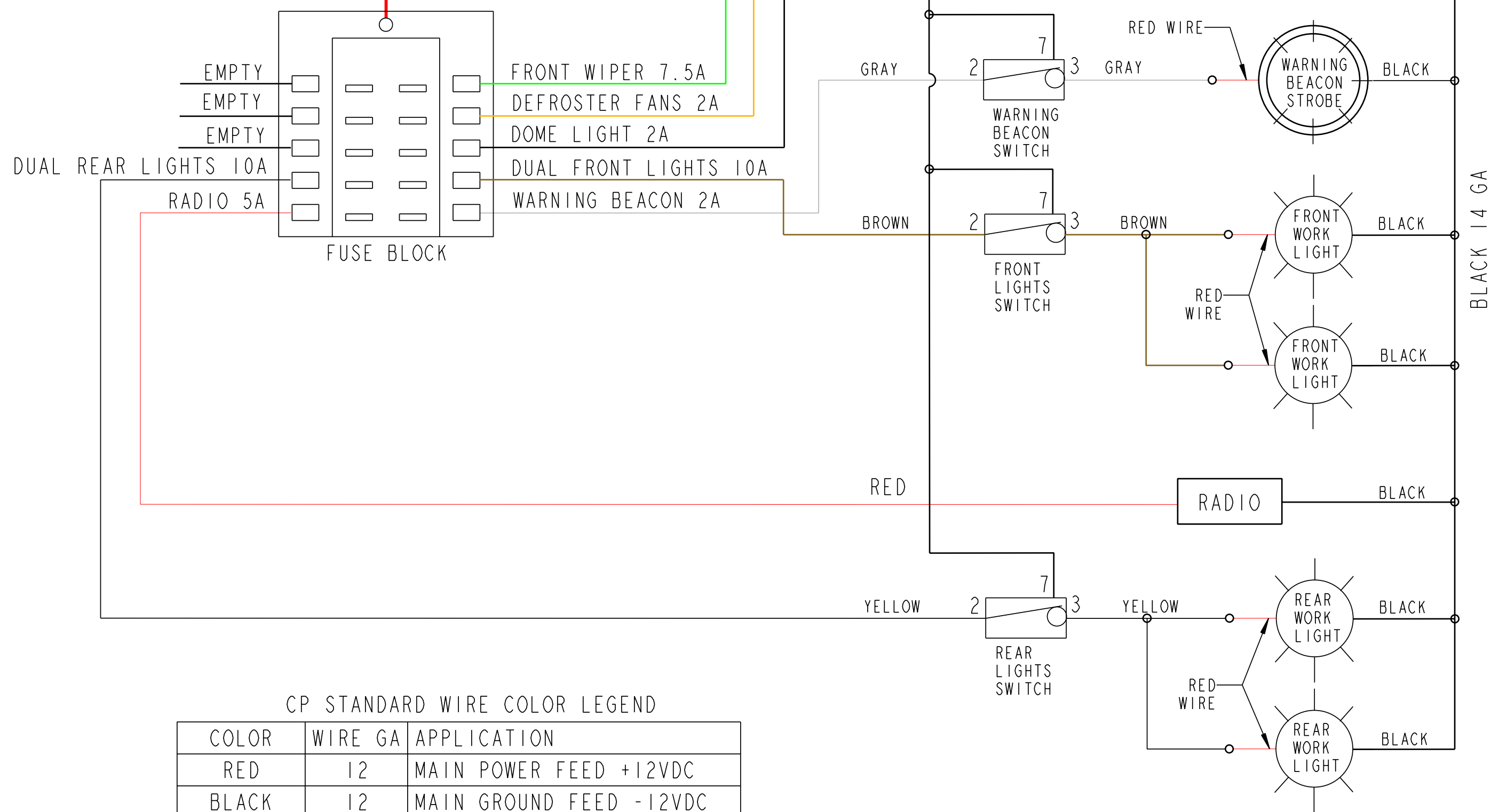
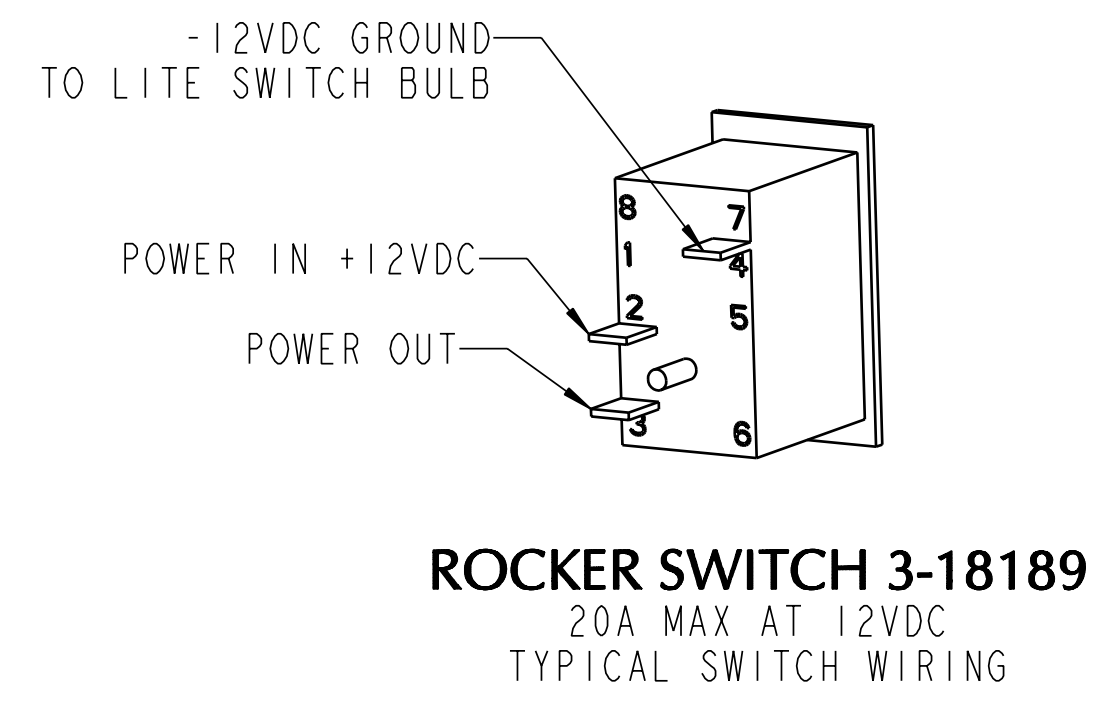
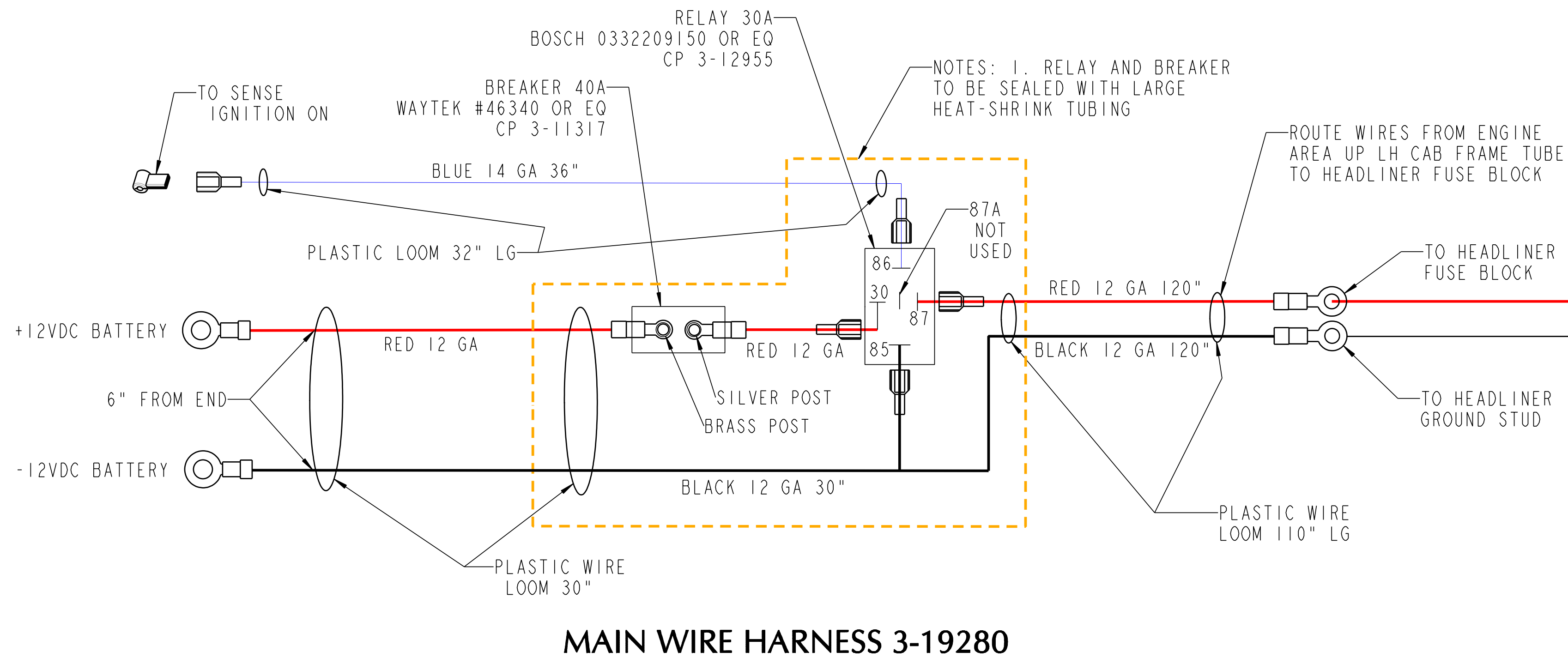

CP STANDARD WIRE COLOR LEGEND

COLOR	WIRE GA	APPLICATION
RED	12	MAIN POWER FEED +12VDC
BLACK	12	MAIN GROUND FEED -12VDC
BROWN	14	FRONT LIGHTS
GREEN	14	FRONT WIPER
WHITE	14	DOME LIGHT
ORANGE	14	DEFROST-COOLING FAN
GRAY	14	WARNING STROBE LIGHT
RED	14	RADIO
BLACK	14	GROUND
DARK BLUE	14	REAR WIPER (NOT SHOWN)
YELLOW	14	REAR LIGHTS

REFER TO WIRE HARNESS DETAILS:  
 3-19281 SWITCHES TO ACCESSORIES WIRE HARNESS  
 3-19282 FUSE BLOCK TO SWITCHES WIRE HARNESS

THIS DOCUMENT CONTAINS CONFIDENTIAL INFORMATION AND IS THE PROPERTY OF CUSTOM PRODUCTS OF LITCHFIELD, INC. AND MAY NOT BE COPIED, REPRODUCED OR DISCLOSED IN ANY MANNER WITHOUT EXPRESSED WRITTEN CONSENT FROM CUSTOM PRODUCTS OF LITCHFIELD, INC.

TOLERANCES UNLESS NOTED OTHERWISE  
 X ± .09  
 JXX ± .06  
 JXXX ± .03  
 HOLE SIZE  
 1/64 ± .00  
 ANGLE ± 5°

CUSTOMER NAME & MOD NO.: EZ CABS  
 CUSTOM PRODUCTS 1715 SOUTH SIBLEY AVE LITCHFIELD, MN 55355

DATE SPEC: 01-27-09

TITLE: WIRE HARNESS KIT  
 DRWG NO.: 4-15389  
 REV LEVEL: A  
 1 of 1

DATE: 01-27-09

NAME: CAD2 OBJECT: 4-15389 DATE: 17-Jun-09 14:19:13

REV.	DCR NO.	DESCRIPTION	DRAFTSMAN	DATE
-	-	DESIGN RELEASE	CAD	01-28-09

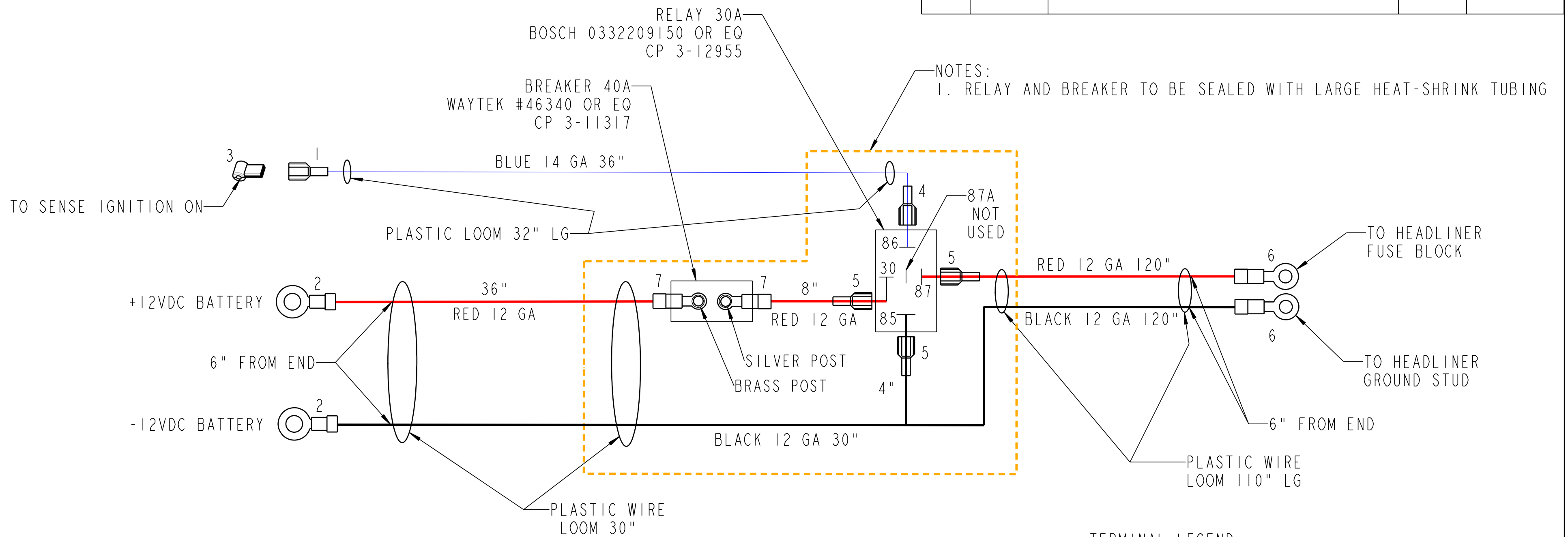

#### WIRE SCHEDULE

COLOR	WIRE GA	LENGTH	APPLICATION
RED	12	36"	MAIN POWER FEED +12VDC
RED	12	8"	BREAKER TO RELAY
RED	12	120"	RELAY TO HEADLINER FUSE BLOCK
BLACK	12	34"	BATTERY TO RELAY
BLACK	12	120"	RELAY TO HEADLINER GROUND STUD
BLUE	14	36"	IGNITION ON SENSING

#### TERMINAL LEGEND

ID No.	QTY	CP P/N	DESCRIPTION
1	1	3-16074	TERMINAL BLADE MALE 1/4" INSUL 14-16 GA
2	2	3-11338	TERMINAL EYE 5/16" YELLOW 10-12 GA
3	1	3-18253	TERMINAL TEE TAP, BLUE 14-16 GA
4	1	3-10670	TERMINAL BLADE FEMALE 1/4" INSUL 14-16 GA
5	3	3-14553	TERMINAL BLADE FEMALE 1/4" INSUL 10-12 GA
6	2	3-10673	TERMINAL EYE 1/4" YELLOW 10-12 GA
7	2	3-10305	TERMINAL EY 3/16" YELLOW 10-12 GA

THIS DOCUMENT CONTAINS CONFIDENTIAL INFORMATION AND IS THE PROPERTY OF CUSTOM PRODUCTS OF LITCHFIELD, INC. AND MAY NOT BE COPIED, REPRODUCED OR DISCLOSED IN ANY MANNER WITHOUT EXPRESSED WRITTEN CONSENT FROM CUSTOM PRODUCTS OF LITCHFIELD, INC.

TOLERANCES UNLESS NOTED OTHERWISE	CUSTOMER NAME & MOD NO: EZ CABS	MATL SPEC:
X ± .09 .XX ± .06 .XXX ± .03 HOLE SIZE .05/-00 ANGLE ± 5°	CUSTOM PRODUCTS 1715 SOUTH SIBLEY AVE LITCHFIELD, MN 55355	
	TITLE: WIRE HARNESS MAIN	DRWG SIZE: C
	DRWG NO: 3-19280	REV LEVEL: -
	DRWN: CAD	DATE: 01-28-09

REV.	DCR NO.	DESCRIPTION	DRAFTSMAN	DATE
A	9593	ADDED REAR LIGHTS WIRING	CAD	06-17-09

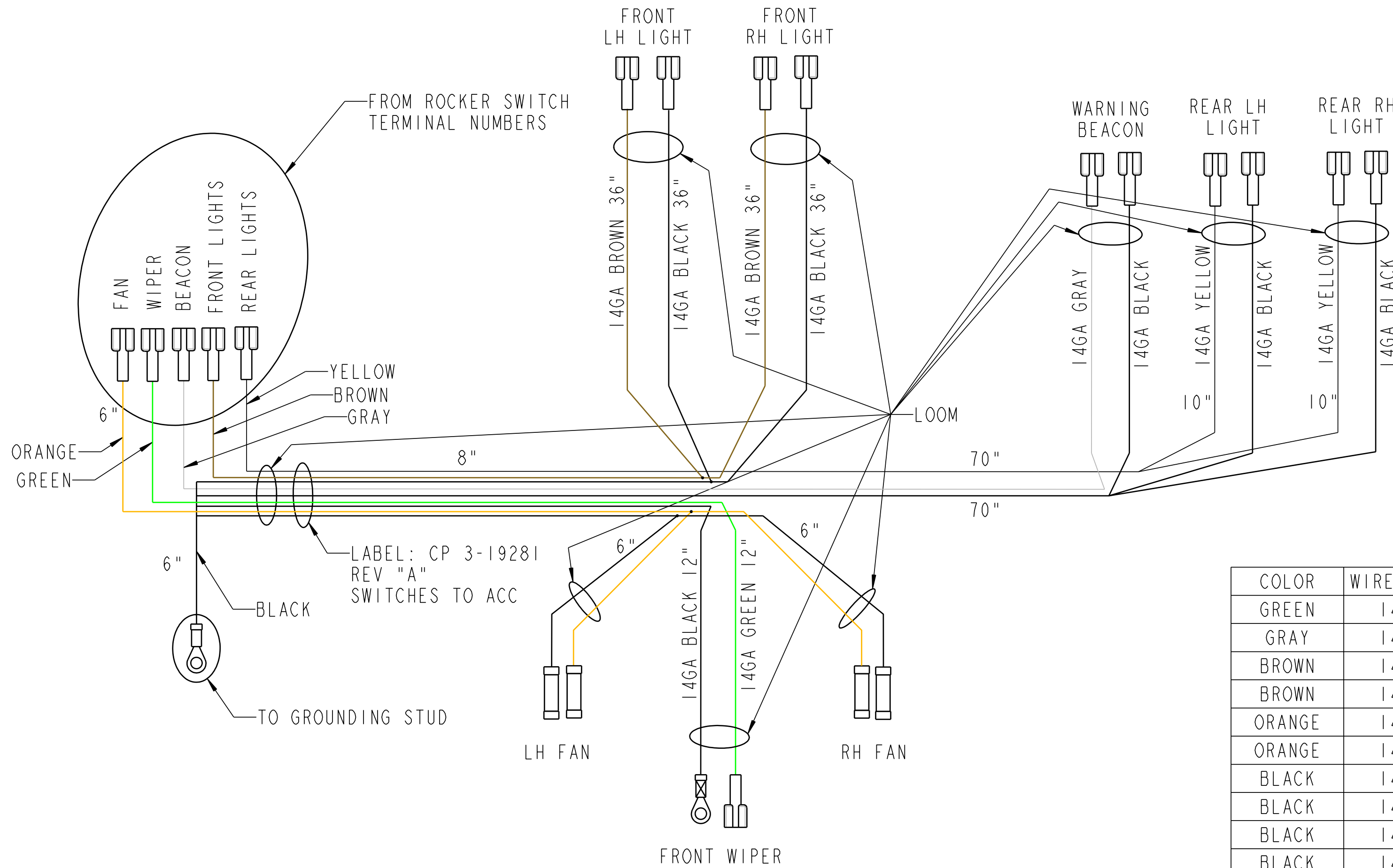

WIRE COLOR LEGEND

COLOR	WIRE GA	LENGTH	APPLICATION
GREEN	14	26"	FRONT WIPER +12V
GRAY	14	84"	WARNING BEACON +12V
BROWN	14	50"	FRONT LIGHT LH +12V
BROWN	14	50"	FRONT LIGHT RH +12V
ORANGE	14	20"	FAN LH +12V
ORANGE	14	6"	FAN RH +12V
BLACK	14	26"	FRONT WIPER GROUND
BLACK	14	84"	WARNING BEACON GROUND
BLACK	14	50"	FRONT LIGHT GROUND
BLACK	14	50"	FRONT LIGHT GROUND
BLACK	14	20"	LH FAN GROUND
BLACK	14	6"	RH FAN GROUND
YELLOW	14	94"	REAR LIGHT LH +12V
YELLOW	14	94"	REAR LIGHT RH +12V
BLACK	14	94"	REAR LIGHT GROUND
BLACK	14	94"	REAR LIGHT GROUND

TERMINAL LEGEND

ID No.	QTY	CP P/N	DESCRIPTION
	16	3-10670	TERMINAL BLADE FEMALE 1/4" INSUL 14-16 GA
	1	3-11434	TERMINAL EYE 1/4" BLUE 14-16 GA
	4	3-10672	TERMINAL BUTT SPLICE BLUE 14-16GA
	1	3-11433	TERMINAL EYE No.10 BLUE 14-16GA

THIS DOCUMENT CONTAINS CONFIDENTIAL INFORMATION AND IS THE PROPERTY OF CUSTOM PRODUCTS OF LITCHFIELD, INC. AND MAY NOT BE COPIED, REPRODUCED OR DISCLOSED IN ANY MANNER WITHOUT EXPRESSED WRITTEN CONSENT FROM CUSTOM PRODUCTS OF LITCHFIELD, INC.

TOLERANCES UNLESS NOTED OTHERWISE	CUSTOMER NAME & MOD NO: EZ CABS	MATL SPEC:
X ± .09 XX ± .06 XXX ± .03 HOLE SIZE .05/-0.00 ANGLE ± 5°	<b>CUSTOM PRODUCTS</b> 1715 SOUTH SIBLEY AVE LITCHFIELD, MN 55355	
	TITLE WIRE HARNESS HEADLINER (SWITCHES TO ACCESSORIES)	DRWG SIZE <b>C</b>
	DRAWN CAD	DATE 01-28-09
		REV LEVEL A

NAME:CAD2 OBJECT:3-19281 DATE:29-Jul-09 09:45:57

REV.	DCR NO.	DESCRIPTION	DRAFTSMAN	DATE
A	9593	ADDED WIRING FOR REAR LIGHTS	CAD	06-17-09

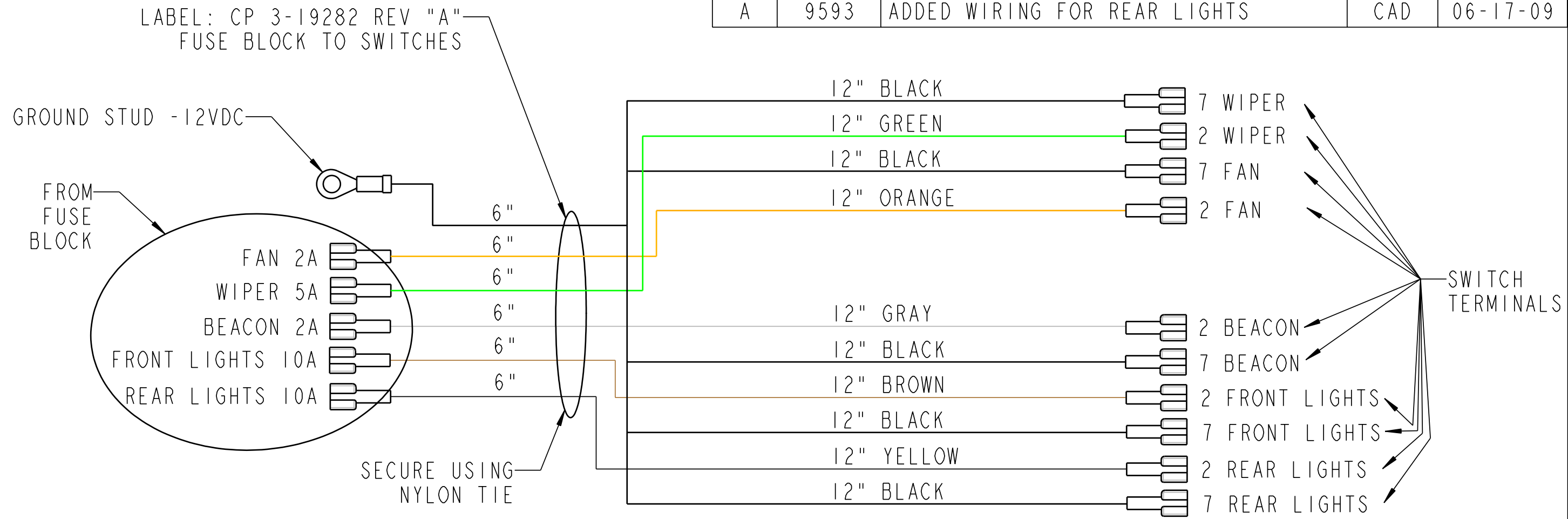

TERMINAL LEGEND

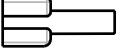
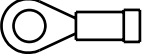
ID No.	QTY	CP P/N	DESCRIPTION
	15	3-10670	TERMINAL BLADE FEMALE 1/4" INSUL 14-16 GA
	1	3-11434	TERMINAL EYE 1/4" INSUL 14-16 GA

WIRE COLOR LEGEND

COLOR	WIRE GA	LENGTH	APPLICATION
GREEN	14	18"	FRONT WIPER
GRAY	14	18"	WARNING BEACON
BROWN	14	18"	FRONT LIGHTS
ORANGE	14	18"	FAN
BLACK	14	18" (5x)	GROUND WIRE
YELLOW	14	18"	REAR LIGHTS

THIS DOCUMENT CONTAINS CONFIDENTIAL INFORMATION AND IS THE PROPERTY OF CUSTOM PRODUCTS OF LITCHFIELD, INC. AND MAY NOT BE COPIED, REPRODUCED OR DISCLOSED IN ANY MANNER WITHOUT EXPRESSED WRITTEN CONSENT FROM CUSTOM PRODUCTS OF LITCHFIELD, INC.

<b>TOLERANCES UNLESS NOTED OTHERWISE</b>  .X ± .09 .XX ± .06 .XXX ± .03 HOLE SIZE .05/.010 ANGLE ± 5°	<b>CUSTOMER NAME &amp; MOD NO.:</b> EZ CABS		<b>MATL SPEC:</b>	
	<b>CUSTOM PRODUCTS</b> 1715 SOUTH SIBLEY AVE. LITCHFIELD, MN 55355			
<b>TITLE</b> WIRE HARNESS FUSE BLOCK TO SWITCHES		<b>DRWG SIZE</b> <b>B</b>	<b>DRWG NO.</b> 3-19282	<b>REV LEVEL</b> A
		<b>DRAWN:</b> CAD	<b>DATE:</b> 01-29-09	