



JOHN DEERE 2210 CAB MOUNTING INSTRUCTIONS



Fits 210 loaders with 2 post non-folding ROPS

A-11289

Manufactured by:



BOX 70 • LITCHFIELD, MINNESOTA 55355-0070
(320) 693-3221 Fax: (320) 693-7252

www.800cabline.com

SAFETY INSTRUCTIONS

Read operator's manual. Be thoroughly familiar with the controls, capabilities, and proper use of the equipment.

NEVER ALLOW ANY RIDERS.

IMPORTANT: This cab must only be used on tractors outfitted with a NON-FOLDING ROPS.

DO NOT place this cab on a tractor outfitted with a folding ROPS.

DO NOT remove the top half of a folding ROPS to accommodate this cab.

Thoroughly inspect cab mounting periodically.

Stay alert for hidden hazards and traffic.

Avoid sudden starts, excessive speeds, and sudden stops when operating on hillside, rough ground and most off-the-road operations.

Use extreme care when working close to fences, ditches, or on hillsides.

Wait for tractor to STOP before dismounting.

Check clearance carefully before driving under any objects.

Avoid operating sideways on a steep slope whenever possible.

ALWAYS buckle safety belt while operating tractor.

Never exceed factory recommended specifications.

DO NOT weld, cut, drill or modify ROPS in any manner unless instructed by manufacturer.

Mounting Instructions John Deere 2210

PREPARATION OF TRACTOR;

1. Park tractor and disconnect battery power.
2. Remove steering wheel.
3. Remove rear amber flashing lights from roll bar.
4. Attach amber lights to single or dual light mounting brackets #7-15827 and #7-15828. Secure lights to bracket with; (See Figure 4).
(4) 8mm x 25mm cap-screws #3-10123
(4) 5/16" lock washers #3-10077
5. Secure brackets to each side of cab using;
(4) 1/4-20unc cap screws x 3/4"lg #3-10219
(4) 1/4-20unc ser flange hex nut #3-14924
(4) 1/4" flat washers #3-10084
6. Install (2) Dual Light Wire Extension Kits #8-14726 and route wires into roll bar where factory rear light wires were routed. See Figure 6. Secure wires with (8) nylon ties, 3-16494.

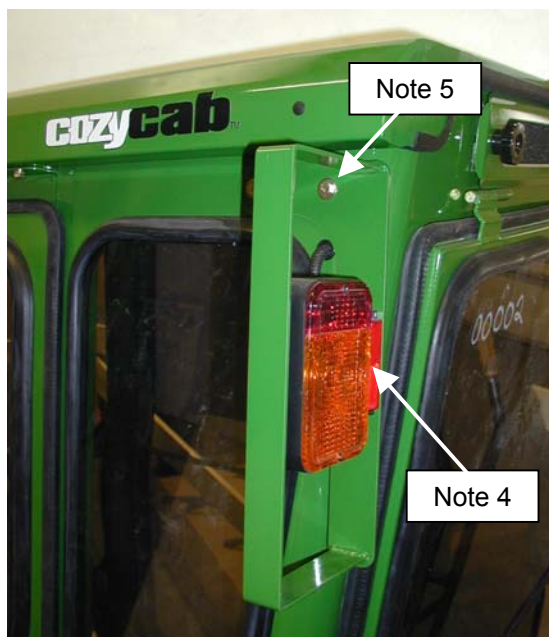

Figure 4

INSTALLING FRONT MOUNT BRACKETS

7. JD factory loader brackets **are not** required to mount the cab's front mount brackets #7-15803 and #7-15804.
8. If the tractor model **does not** have a loader, install (2) Spacers #6-43373 using (4) Metric bolts 3-17372 and (4) 1/2" lock washers 3-10079, with the cab's front mount brackets.
9. If tractor model **does** have a loader, remove (4) of the JD front loader bolts and install (4) 12mm x 40mm bolts with the front mount brackets. **Spacers are not required if tractor has factory JD loader mounts.** Install (2) rubber isolators #3-16635. NOTE: Rubber Isolators (#3-16635) with pipe bushing should be inserted from the top-side of mount. See Figure 8.

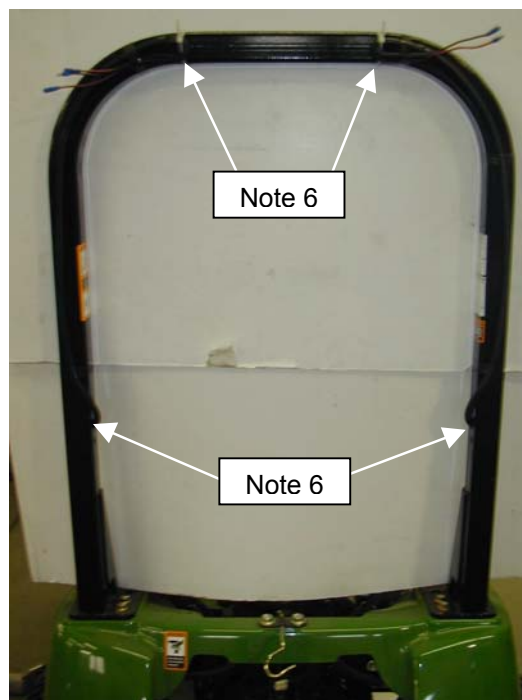

Figure 6

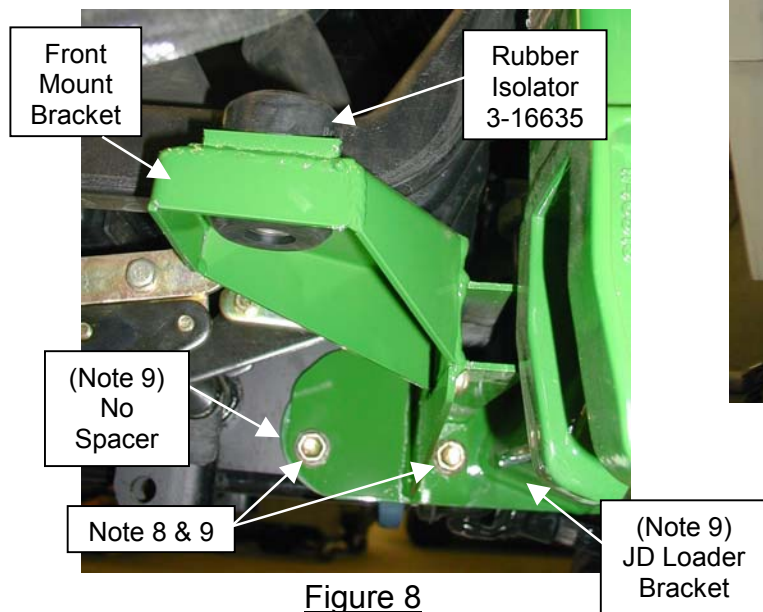

Figure 8

(Model shown has JD Loader Brackets)

Mounting Instructions John Deere 2210

INSTALLATION OF CAB

10. Install (2) lift brackets #6-42570 using (2) ¼-20 bolts x ¾" long #3-10219 and (2) ¼" flat washers #3-10084. Remove cab from shipping stand. Lower cab over roll bar until cab contacts **front** isolator bushings (See Figure 10). Support rear of cab until front mounts are secured.
11. Place rubber floor mat #3-18046 onto tractor's operator deck. Fit (2) bubble rubber retainers 3-15952, 20" long to secure floor mat. See Figure 11.
12. Secure **front** of cab to rubber bushings with;
 - (2) ½-13unc x 5.0" long Bolts #3-10412
 - (2) ½-13unc Nyloc Nuts #3-10379
 - (2) ½" Flat Washers Wide #3-16830
 With front of cab secured, the rear mounts can be installed.

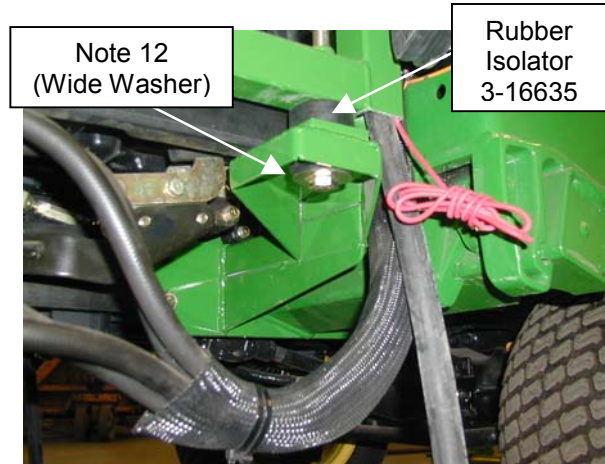

Figure 10

INSTALLING REAR MOUNT BRACKETS

13. Install (2) rubber isolator bushings to rear bracket mounts. NOTE: Isolator mounts (#3-16635) with pipe bushing should be inserted from the front side of mount. See Figure 13.
14. Secure rear mount brackets 7-15796 and 7-15797 to roll bar with;
 - (4) 3/8-16unc U-bolts #3-18000
 - (8) 3/8" ser flange hex nuts #3-17672
15. Secure **rear** of cab to rear mount brackets with;
 - (2) ½-13unc x 3.25" long Bolts #3-15057
 - (2) ½-13unc nyloc nuts #3-10379
 - (2) ½" Flat Washers Standard #3-10087
 - (2) ½" Flat-Wide Washers #3-16830

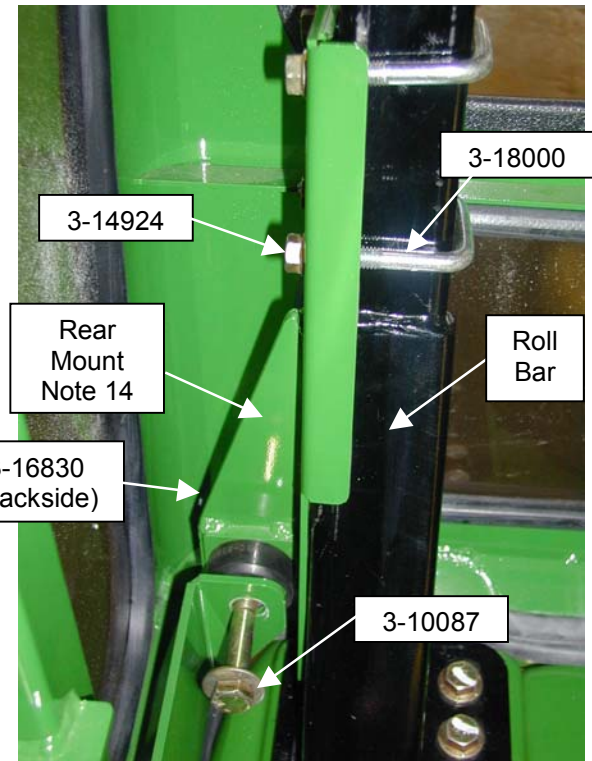
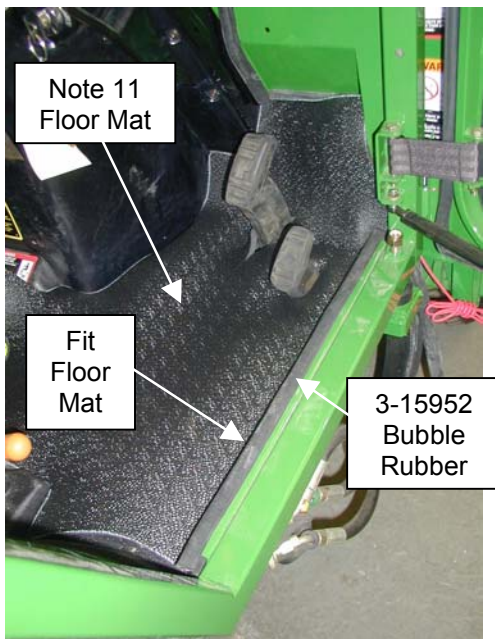

Figure 13



Mounting Instructions John Deere 2210

HOOD PANEL;

- Secure hood panel 8-14731 with;
 - (4) 1/4-20unc x 3/4" long bolts, #3-10219
 - (4) 1/4" flat washers, #3-10084
 - (4) 1/4-20unc ser flange hex nuts, #3-14924- Remount steering wheel

SMV SIGN RELOCATION;

- Remove Slow Moving Vehicle sign and bracket from tractor seat. Re-mount sign using holes located on the bottom window face panel. Bracket is not required. Use;
 - (2) Spacers #6-41217
 - (2) Hex bolts 1/4-20 x 1.75 long
 - (2) 1/4-20unc ser flange hex nuts.

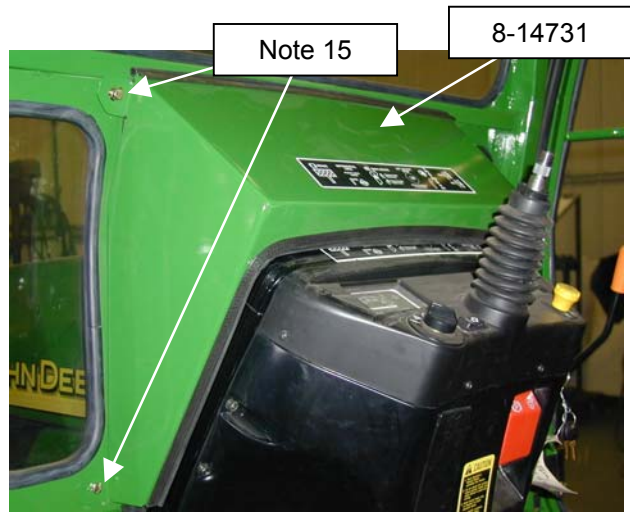

Figure 15

ELECTRICAL HOOKUP

- Open hood and remove side panels. Mount #3-17803 Universal Wire Relay Breaker Kit in the engine compartment area. See Figure 16.
- Refer to drawing #3-17803 and # 8-14376 for additional electrical connections and details.
- Make sure the cab is grounded to frame by installing cab to ground wire #8-14258. See Figure 19.



Figure 19

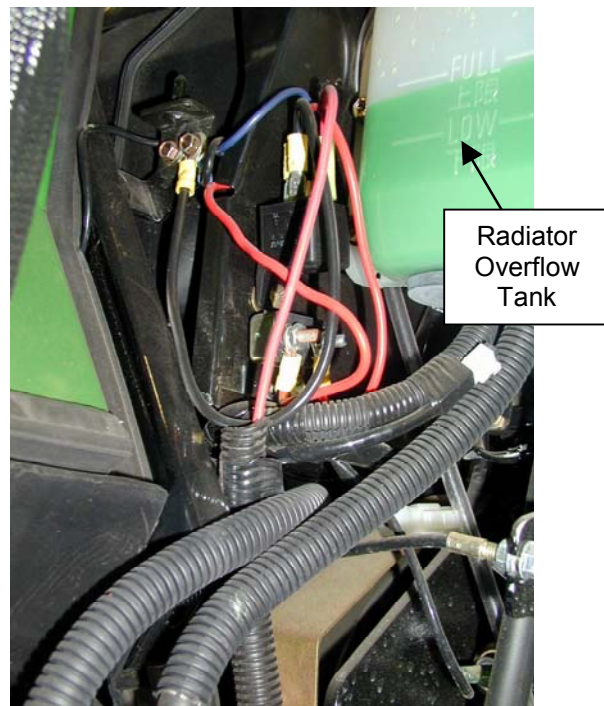

Figure 16

Mounting Instructions John Deere 2210

HEATER HOSE HOOKUP (Ref. Drawing #8-14751)

20. Drain coolant from radiator and engine block.
21. Remove temperature sensor from thermostat housing area.
22. Install aluminum fitting #3-15815 **with O-ring washer #3-16823** into thermostat housing. See Figure 21.
23. Re-install temperature sensor into the aluminum fitting just installed (Step 20).
24. Install hose to NPT fitting #3-12119 into the side port of the aluminum fitting.
25. Measure and cut the 5/8" heater hose that routes (supply line) from the left (driver side) of the cab to the thermostat-aluminum-hose nipple fitting. Plastic elbow #3-10282 should be used at the bottom of the cab tubes. See Figure 25.

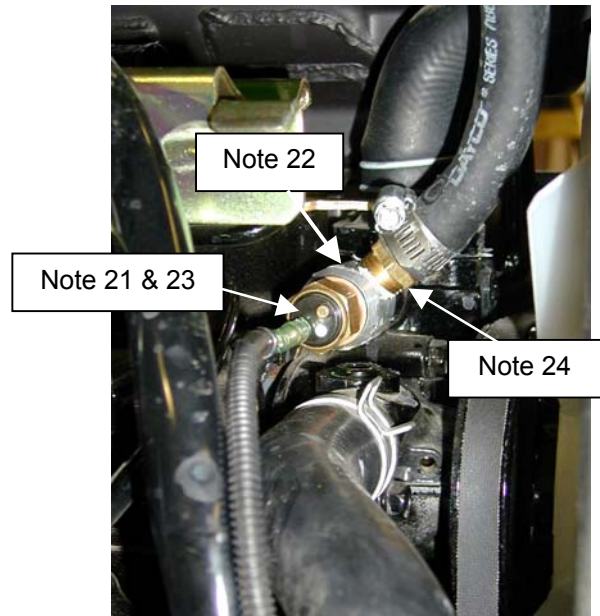

Figure 21

26. The lower radiator hose will need to be cut for installation of the lower radiator hose "T" fitting #7-11308. See Figure 25.
27. Install 5/8" hose to NPT fitting #3-12119 into the lower radiator hose "T" fitting. See Figure 25.
28. Measure and cut the 5/8" heater hose from the right side (Return Line) of the cab with the 90-degree elbow #3-10282 to the lower radiator hose "T" nipple fitting. See Figure 25.
29. Tighten all hose connections with hose clamps.
30. Re-connect Battery Power.
31. Refill radiator. Start engine and run at fast idle to purge air from coolant system. Make sure the Heat-Pull Lever is pulled out (Turned On).
32. Check for leaks.
33. Check coolant level after heater core and hoses are filled.

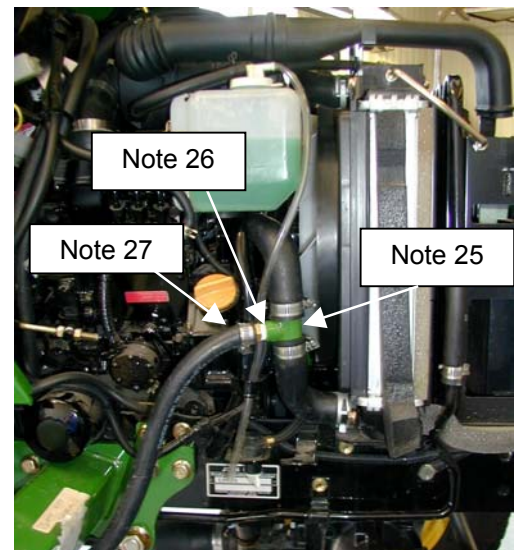

Figure 25

VERTICAL EXHAUST KIT

34. For applications that require a high exhaust system, over the head of the operator, a vertical exhaust kit may be available. Check with your local John Deere dealer.

John Deere 2210 Mounting Instructions

Drawing Index

8-14706	CAB ASSEMBLY JD 2210
8-14707	CAB MOUNTING KIT
8-14708	DOOR ASSEMBLY LH
8-14709	DOOR ASSEMBLY RH
8-14486	HEADLINER ASSEMBLY
8-14731	HOOD ASSEMBLY
8-14487	ROOF ASSEMBLY
8-14491	REAR WINDOW ASSEMBLY
8-14376	ELECTRICAL SCHEMATIC
3-17803	WIRE RELAY BREAKER HARNESS
8-14751	HEATER HOOK UP KIT

John Deere 2210
Replacement Parts A-11289
8-14706 Cab Assembly

<u>ITEM</u>	<u>QTY</u>	<u>PART NO.</u>	<u>DESCRIPTION</u>
1	1	7-15800	CAB WELDMENT JD 2210
2	1	8-14707	MOUNT KIT FOR JD 2210
3	1	8-14708	DOOR ASSEMBLY LH
4	1	8-14709	DOOR ASSEMBLY RH
5	1	8-14486	HEADLINER ASSEMBLY
6	1	8-14487	ROOF ASSEMBLY
7	1	8-14491	REAR WINDOW ASSEMBLY
8	1	3-17942	FILTER
9	1	6-43134	FILTER RETAINER PLATE
10	4	3-13473	HEX HEAD CAP SCREW 3/8-16UNC x 3 LG
11	2	6-41531	NYLON LOOP DOOR STRAP
12	2	3-15407	STRIKER DOOR STUD LONG
13	2	3-10166	FLAT WASHER, 7/16"
14	2	3-10472	NYLOCK NUT, 7/16-14UNC
15	8	3-14387	NUTSERT 1/4-20UNC
16	8	3-10076	LOCK WASHER 1/4"
17	8	3-10220	HEX HEAD CAP SCREW 1/4-20UNC x 1 LG
18	4	3-10073	NYLOCK NUT, 3/8-16UNC
19	2	3-11821	BALL STUD FOR GAS DOOR SPRING
20	2	3-10077	LOCK WASHER 5/16"
21	2	3-10064	HEX NUT 5/16-18UNC
22	2	3-13024	GAS SPRING 20 LBS x 6" STROKE
23	4	3-11822	GAS SPRING RETAINER CLIP
24	1	3-11099	WIPER MOTOR 12VDC SINGLE SPEED
25	2	3-10083	FLAT WASHER NO. 10
26	2	3-10135	MACHINE SCREW NO. 10 TRUSS HD SL
27	2	3-10308	NYLOCK NUT 10-24UNC
28	1	3-15776	WIPER ARM WWF 16"
29	1	3-15763	WIPER BLADE 16"
30	4	3-10085	FLAT WASHER 3/16"
31	2	3-15573	KNOB 1.75 DIA x 5/16-18UNC
32	1	3-18036	FRONT WINDOW TEMPERED
33	2	3-18039	FRONT PEEK WINDOW TEMPERED
34	1	3-17586	REAR LOWER WINDOW TEMPERED
35-36	2	3-17580	SIDE REAR WINDOW TEMPERED
37,38,47,48	1	3-10610	WINDOW RUBBER FOR 1/8" GLASS
39,40,45	1	3-15952	BUBBLE RUBBER FOR 14 GA 90 DEG
40,41,43,44	1	3-10778	EDGE TRIM LARGE
46	2	3-14441	HOLE GROMMET .562
49	1	3-17171	SERIAL NUMBER TAG

REV.	DCR NO.	DESCRIPTION	DRAFTSMAN	DATE
A1	-	CHANGE OUT GLASS PEEK WITH LEXAN	CAD	9-23-03
A2	-	ADDED (2) GROMMETS 3-14441	CAD	9-23-03
A3	-	UPDATED BRUBBER	CAD	9-25-03

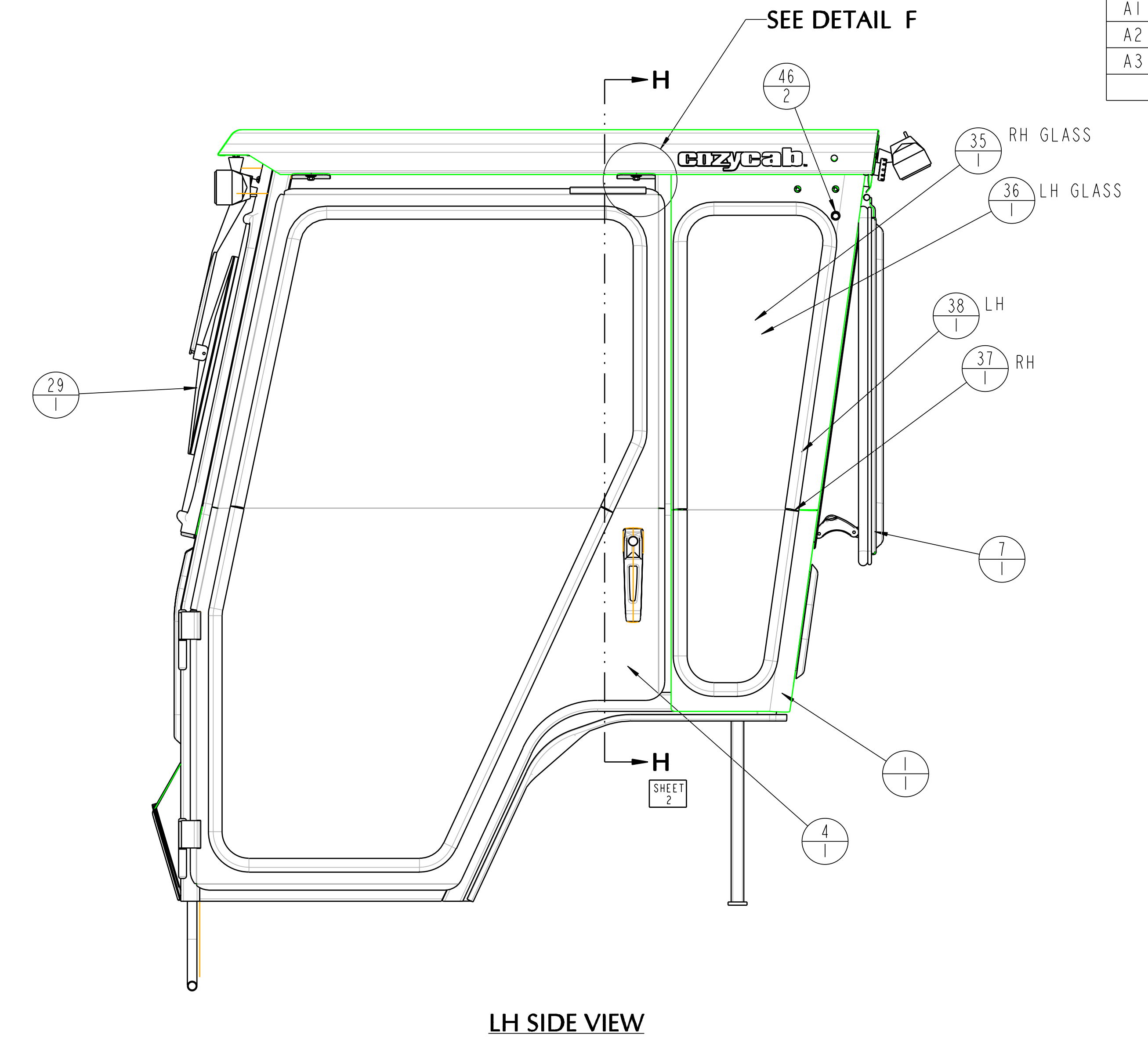
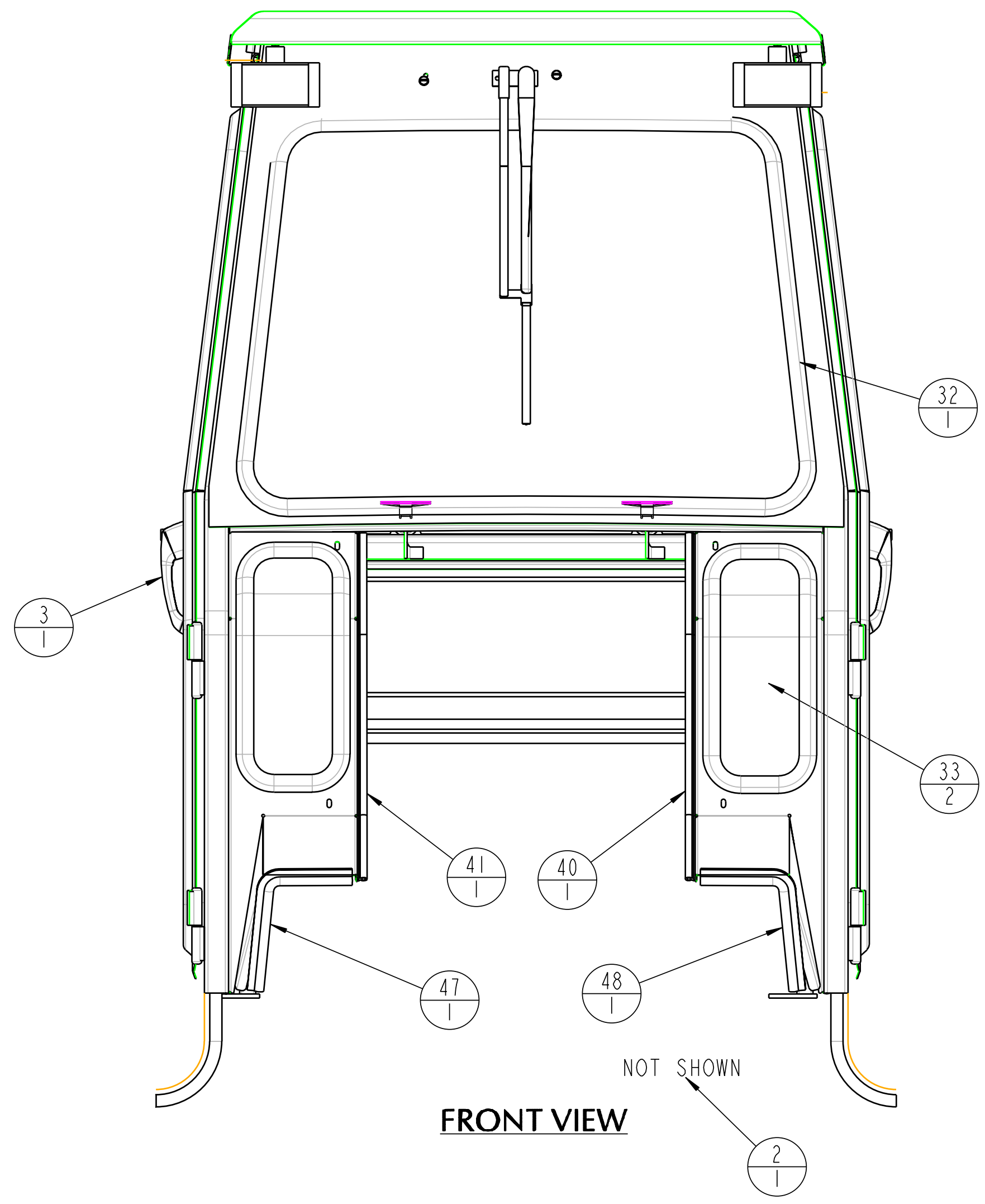

WINDOW RUBBER AND BUBBLE RUBBER SCHEDULE

SCALE 0.150

PART NUMBER	DESCRIPTION	LENGTH (FT)
3-16669	FRONT WINDOW 1/8" GLASS	9.17
3-16669	FRONT PEEK 1/8" GLASS	3.16 (2 EA)
3-16669	DOOR 1/8" GLASS	12.33 (2 EA)
3-16669	CAB SIDE 1/8" GLASS	7.60 (2 EA)
3-10649	REAR WINDOW ASY 1/4" GLASS	8.50
3-10649	REAR LOWER 1/4" GLASS	6.57
3-15952	REAR WINDOW ASY B-RUBBER	10.25
3-15952	DOOR B-RUBBER	14.25 (2 EA)
3-15952	FENDER B-RUBBER	2.77 (2 EA)
3-10610	REAR LOWER B-RUBBER	3.08
3-15952	SIDE HOOD B-RUBBER	1.50 (2 EA)
3-15068	FRONT B-RUBBER	1.82
3-15068	HOOD SEAL B-RUBBER	3.47
3-10778	REAR WINDOW TRIM SEAL	9.67
3-16521	ROOF REAR B-RUBBER	3.50
3-16521	ROOF SIDE B-RUBBER	3.82 (2 EA)
3-15068	ROOF FRONT SHORT B-RUBBER	0.33 (2 EA)
3-10610	FRONT LOWER B-RUBBER	1.1 (2 EA)
3-15952	DOOR MAT B-RUBBER	20.00 (2 EA)

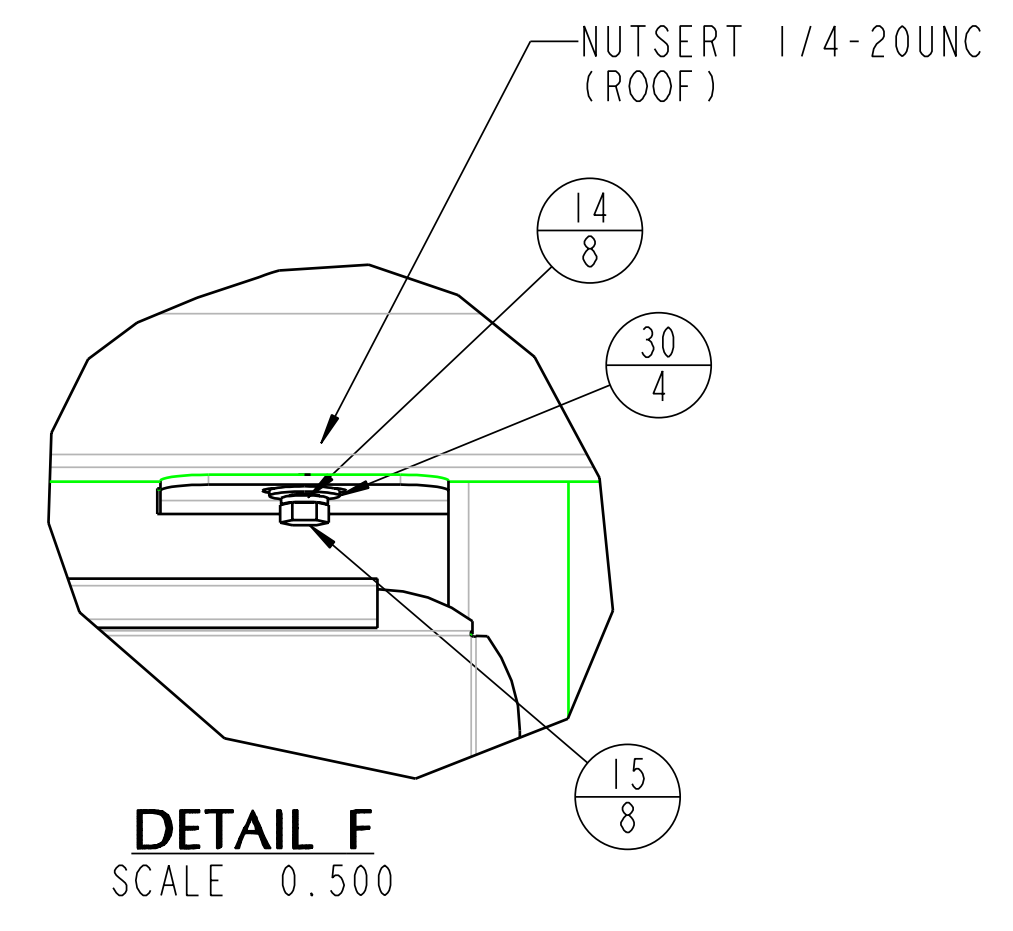

- NOTES:
- WIPER SETTING: 100 DEGREES
 - FINISH:
SEAL WITH WHITE MAJESTIC SEALANT 3-11219, .13 PT
PRIME COAT: PRIMER, RED OXIDE 3-15315, .73 GAL
WITH ACTIVATOR 3-15316, .375 GAL
THINNER 3-15317 (THINNER ADD 10%) .12 GAL
TOP COAT: PAINT, JD GREEN, 3-11006 1.0 GAL
 - ADHESIVE SPRAY FOR POLYFOAM LT ORANGE 3-16326, .1 GAL
 - LIGHTS ARE STANDARD EQUIPMENT
 - CAB TO BE SHIPPED ON PALLET P-414
 - MOUNT KIT COMPONENTS SHOWN FOR REFERENCE ONLY

- KIT OPTIONS:
- 4-14424 REAR WIPER
 - 4-14426 TOP FLASHING WARNING LIGHT

BALLOON INFORMATION
ITEM NO. 011

THIS DOCUMENT CONTAINS CONFIDENTIAL INFORMATION AND IS THE PROPERTY OF CUSTOM PRODUCTS OF LITCHFIELD, INC. AND MAY NOT BE COPIED, REPRODUCED OR DISCLOSED IN ANY MANNER WITHOUT EXPRESSED WRITTEN CONSENT FROM CUSTOM PRODUCTS OF LITCHFIELD, INC.

TOLERANCES UNLESS NOTED OTHERWISE	CUSTOMER NAME & MOD NO.	JOHN DEERE 2210	MATL SPEC.	SEE BOM
	CUSTOM PRODUCTS	1715 SOUTH SIBLEY AVE	LITCHFIELD, MN 55355	
	TITLE	CAB ASSEMBLY	DRWG NO.	8-14706
			REV LEVEL	A
			DRWG SIZE	D
			DATE	7-18-03

ANGLE ± 5°

REV.	DCR NO.	DESCRIPTION	DRAFTSMAN	DATE
-	-	PRODUCTION RELEASE	CAD	9-24-03

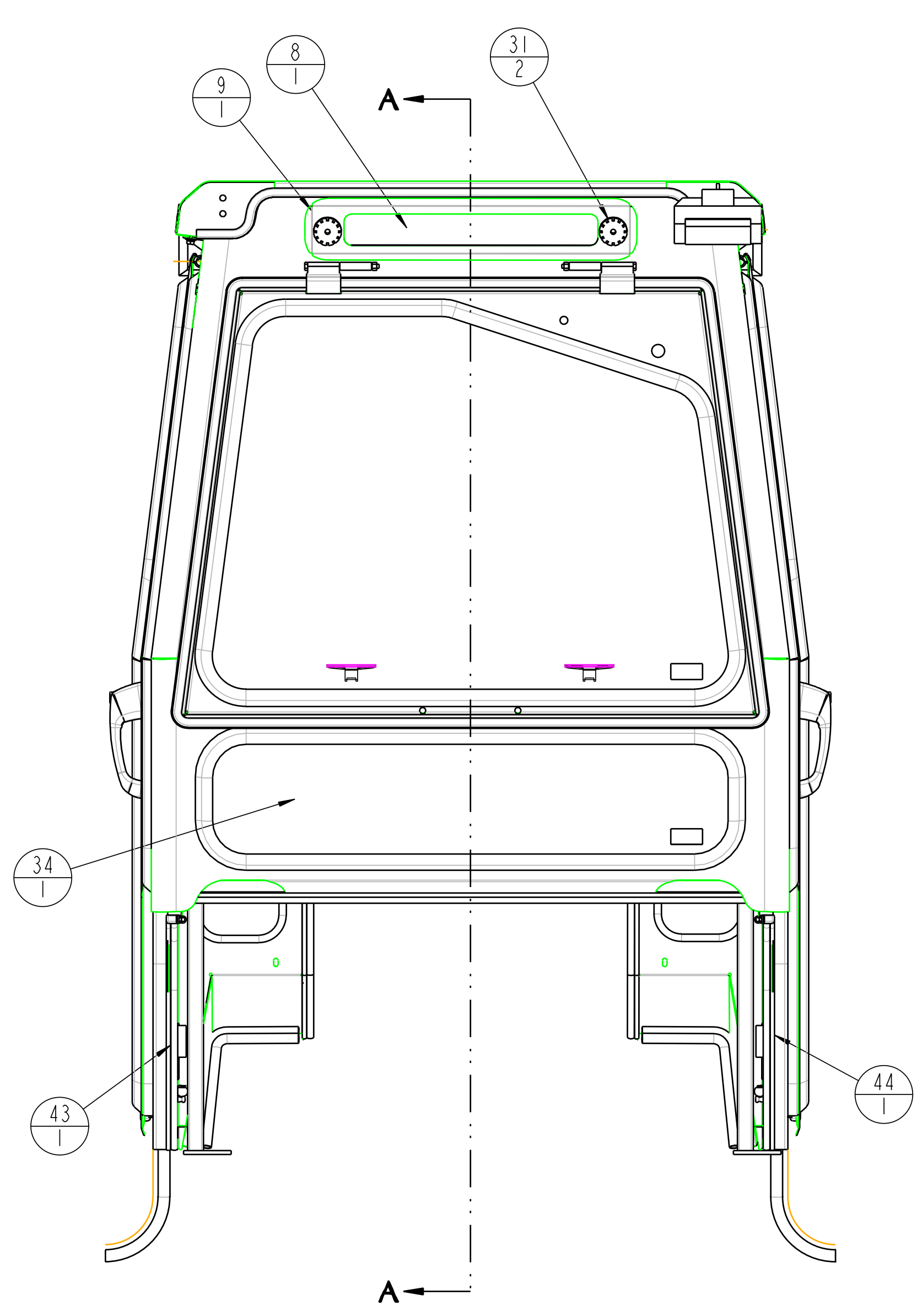

REAR VIEW

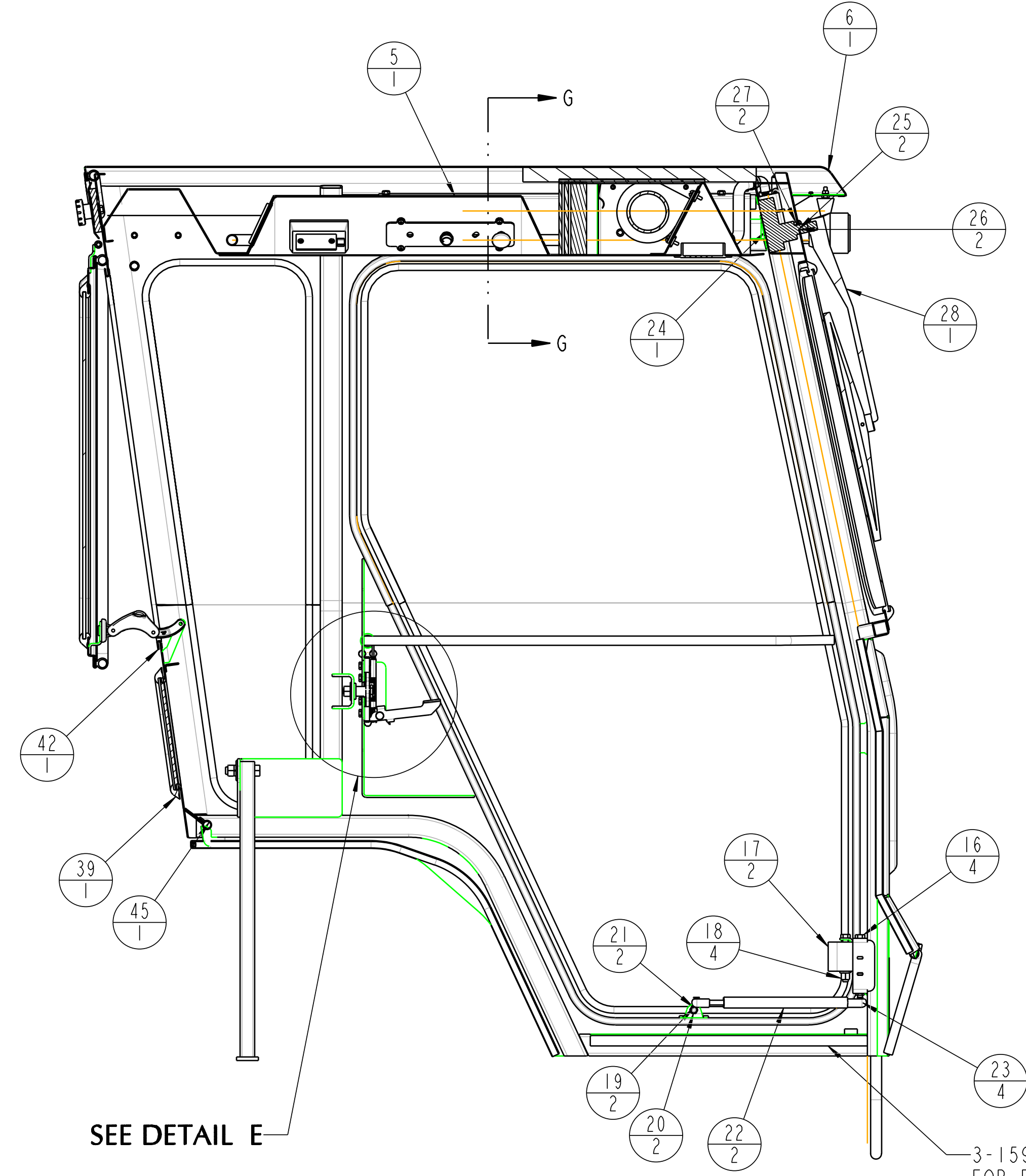

SECTION A-A

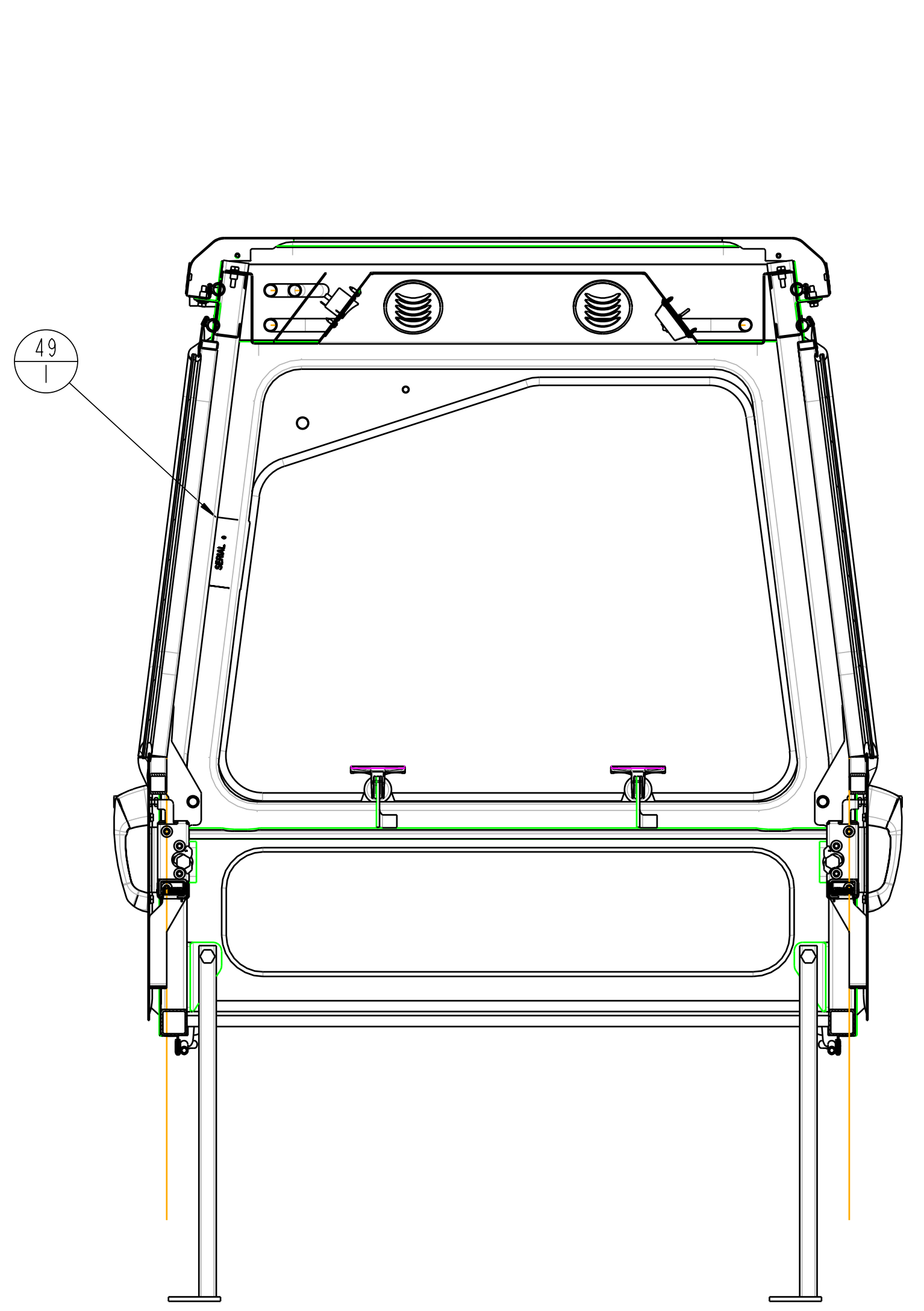

SECTION H-H
SCALE 0.150 SHEET 1

3-15952 BUBBLE RUBBER FOR FLOOR MAT RETAINING 20.00" LONG -BOTH SIDES

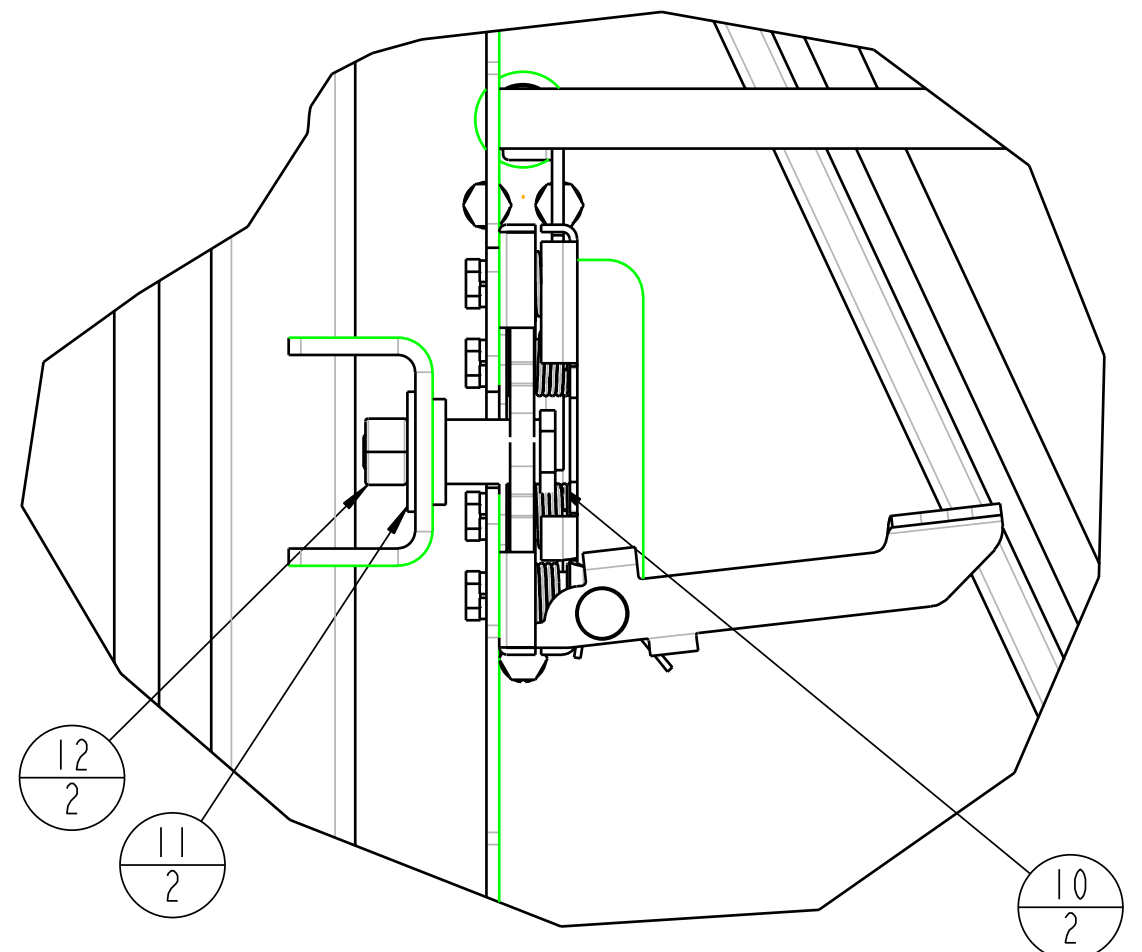

DETAIL E
SCALE 0.500

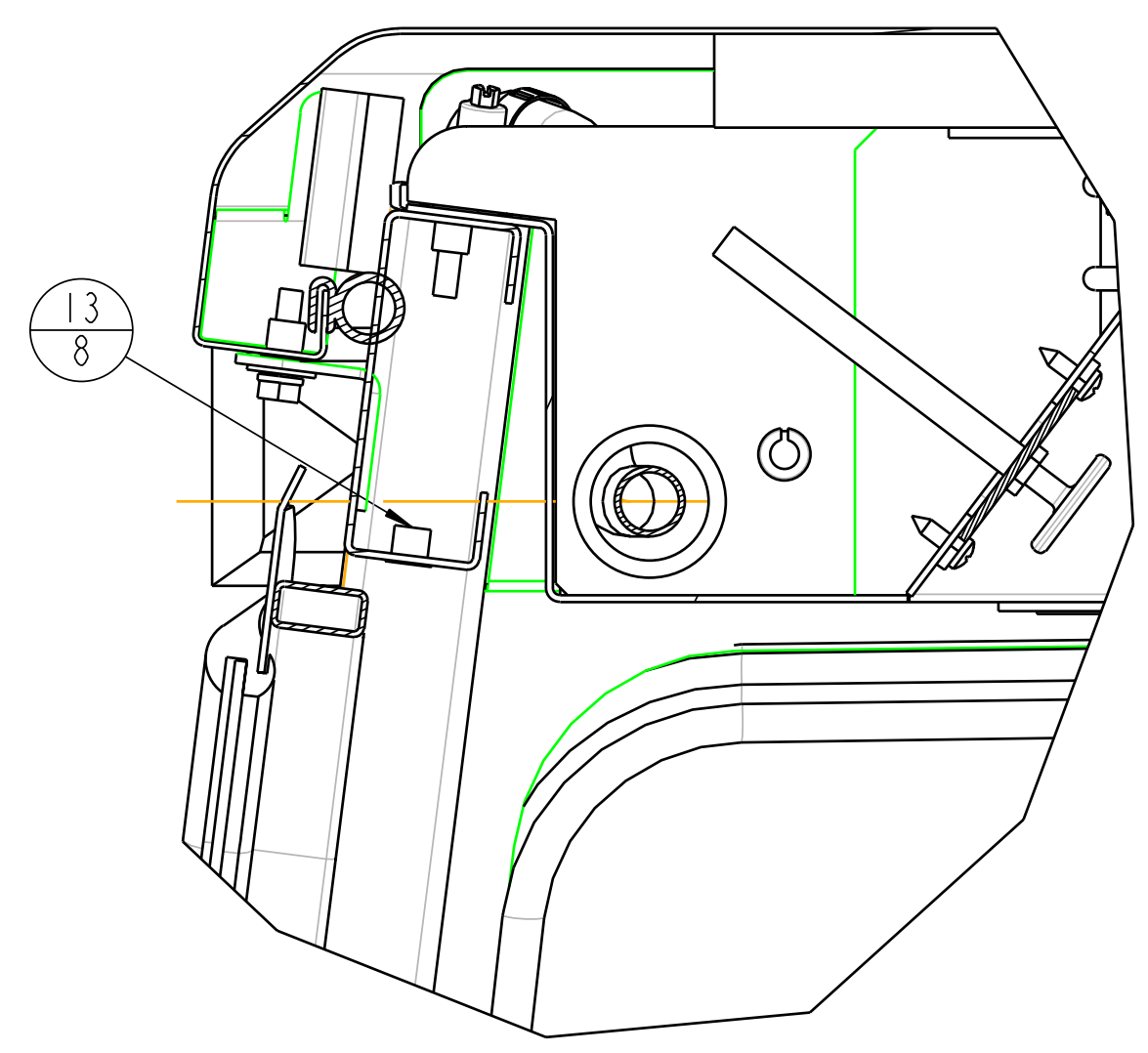

SECTION G-G
SCALE 0.500

BALLOON INFORMATION
ITEM NO.
QTY

THIS DOCUMENT CONTAINS CONFIDENTIAL INFORMATION AND IS THE PROPERTY OF CUSTOM PRODUCTS OF LITCHFIELD, INC. AND MAY NOT BE COPIED, REPRODUCED OR DISCLOSED IN ANY MANNER WITHOUT EXPRESSED WRITTEN CONSENT FROM CUSTOM PRODUCTS OF LITCHFIELD, INC.

TOLERANCES UNLESS NOTED OTHERWISE	CUSTOMER NAME & MOD NO.	JD 2210	MATL SPEC	SEE SHEET 1
.X ± .09 .XX ± .06 .XXX ± .03 HOLE SIZE 05/00 ANGLE ± 5°	CUSTOM PRODUCTS	1715 SOUTH SIBLEY AVE LITCHFIELD, MN 55355	DRWG NO.	8-14706 2 of 2
TITLE		CAB ASSEMBLY	DRWG NO.	REV LEVEL
DRAWN		CAD	DATE	7-18-03

John Deere 2210
Replacement Parts A-11289
8-14707 Cab Mounting Kit

<u>ITEM</u>	<u>QTY</u>	<u>PART NO.</u>	<u>DESCRIPTION</u>
2	1	7-15796	REAR MOUNT RH
3	1	7-15797	REAR MOUNT LH
4	1	7-15803	FRONT MOUNT RH
5	1	7-15804	FRONT MOUNT LH
6	4	3-18000	U-BOLT SQ 2x3x2
7	2	6-43373	FRONT MOUNT SPACER
8	2	3-10412	HEX HEAD CAP SCREW 1/2-13UNC x 5.00" LG
9	4	3-16635	RUBBER MOUNT
10	2	3-15057	HEX HEAD CAP SCREW 1/2-13UNC x 3.25" LG
11	4	3-10379	NYLOCK NUT 1/2-13UNC
12	4	3-16830	FLAT WASHER, 1/2" WIDE
13	2	3-10087	FLAT WASHER, 1/2" STANDARD
14	1	7-15827	LIGHT BRACKET LH
15	1	7-15828	LIGHT BRACKET RH
16	8	3-17622	HEX NUT SER FLANGE, 3/8-16UNC
17	10	3-10219	HEX HEAD CAP SCREW, 1/4-20UNC x 3/4" LG
18	1	3-17803	WIRE RELAY BREAKER KIT
19	1	8-14258	CAB TO GROUND WIRE ASSEMBLY
20	2	8-14726	REAR LIGHT WIRE EXTENSION KIT
21	1	8-14751	HEATER KIT FOR JD 2210
22	1	05-10433	INSTRUCTION MANUAL FOR JD 2210 CAB
23	1	8-14731	HOOD ASSEMBLY
24	10	3-14924	HEX NUT SER FLANGE, 1/4-20UNC
25	10	3-10084	FLAT WASHER, 1/4" STANDARD
26	2	6-42570	LIFTING EAR
27	4	3-10123	METRIC HEX HD CAPSCREW, M8 x 25 x 1.25C
28	4	3-17372	METRIC HEX HD CAPSCREW, M12 x 40 x 1.75C
29	4	3-10077	LOCK WASHER, 5/16"
30	4	3-10079	LOCK WASHER, 1/2"
31	2	6-41217	SMV SPACER
32	2	3-10383	HEX HEAD CAPSCREW, 1/4-20UNC x 1.75 LG
33	1	3-16265	(REFERENCE) ZIP LOCK BAG
34	8	3-16494	NYLON TIE, BLACK, 8.875 LG
35	1	3-18046	FLOOR MAT FOR JD2210
36	2	3-15952	BUBBLE RUBBER, 20" LG

REV.	DCR NO.	DESCRIPTION	DRAFTSMAN	DATE
A	-	HEATER KIT 4-14751 WAS 4-14593	CAD	8-5-03
B	-	PROTOTYPE RELEASE	CAD	9-23-03
C	-	PRODUCTION RELEASE	CAD	10-1-03
D	8119	FASTENER 3-17372 WAS 3-12356	CAD	5-5-04

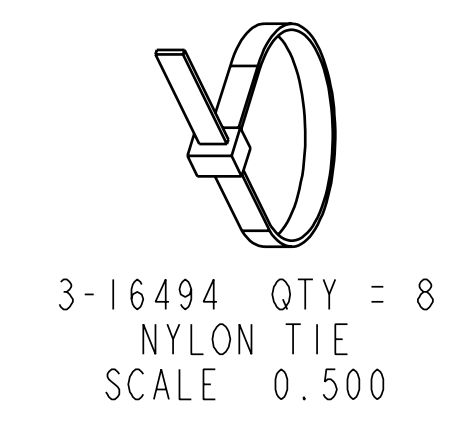
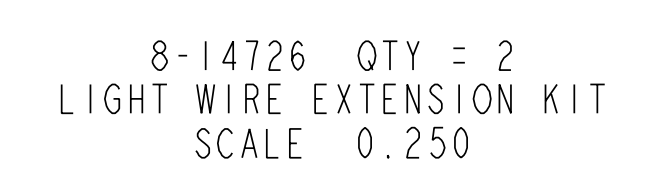
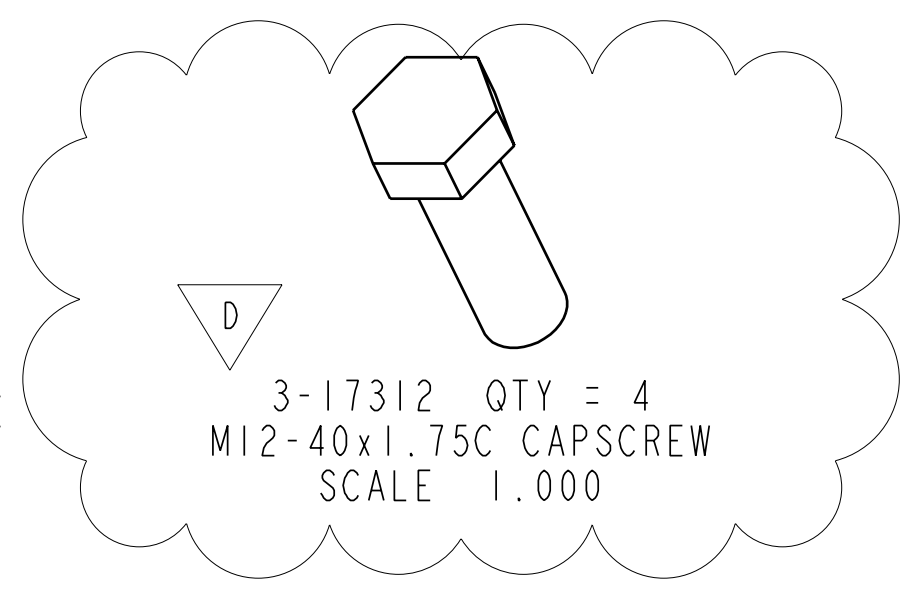
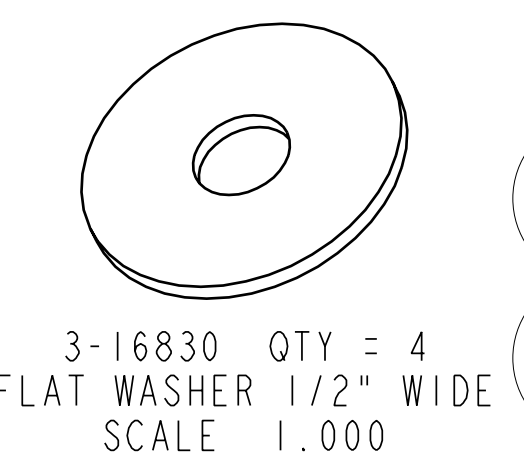
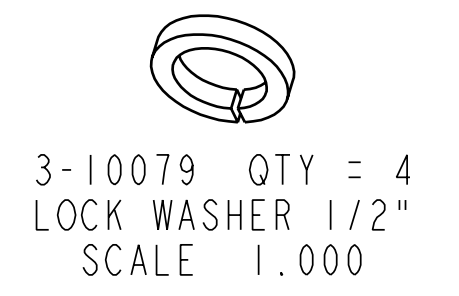
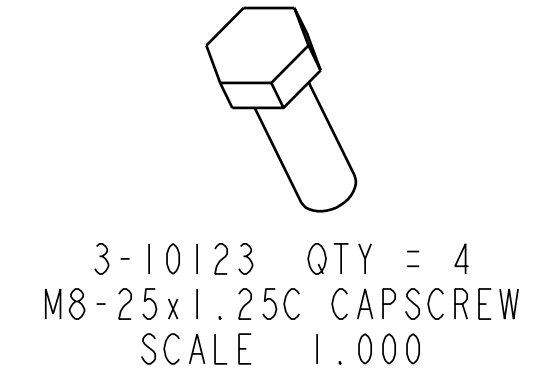
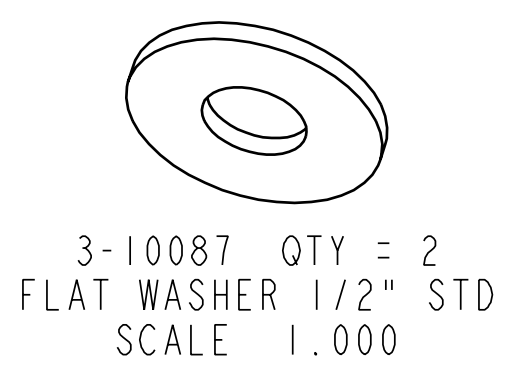
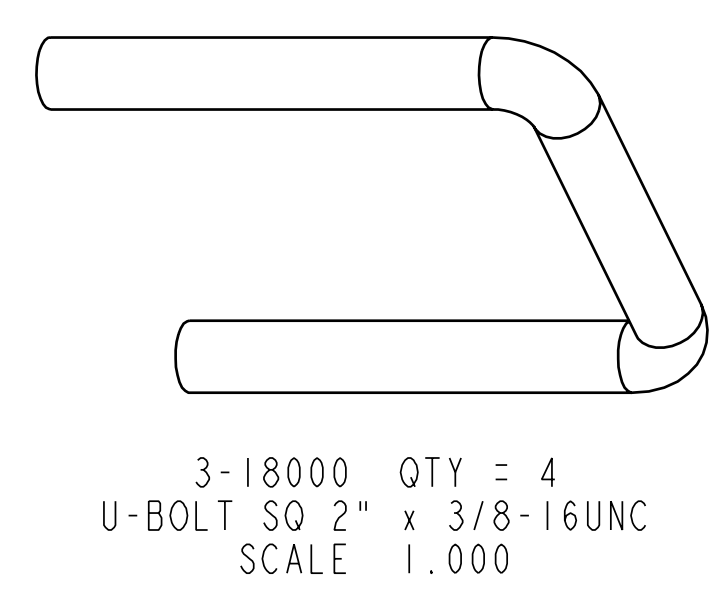
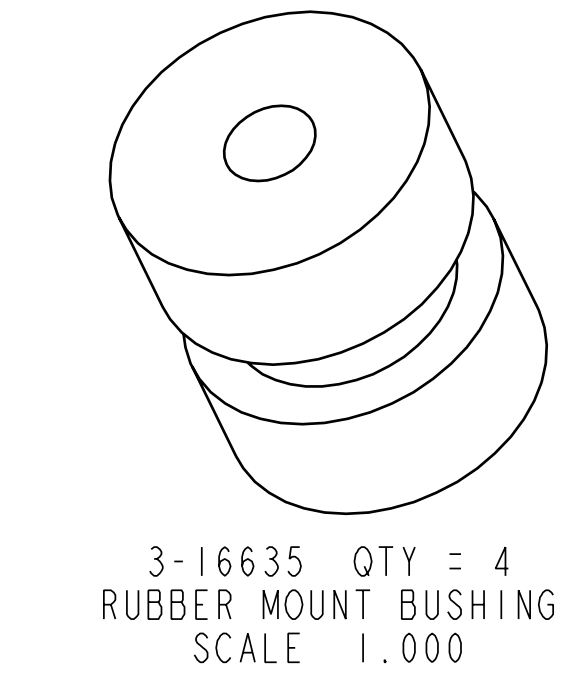
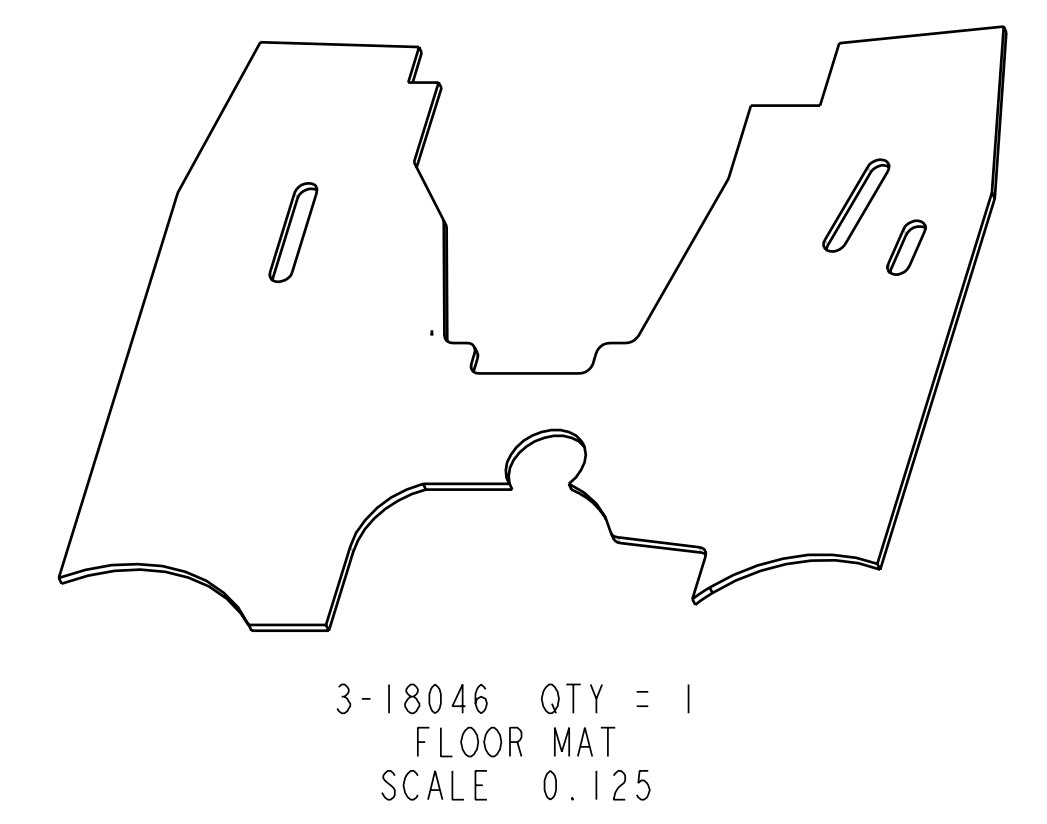
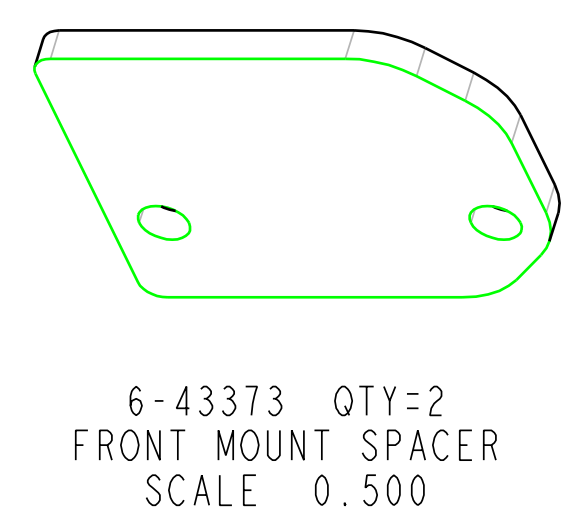
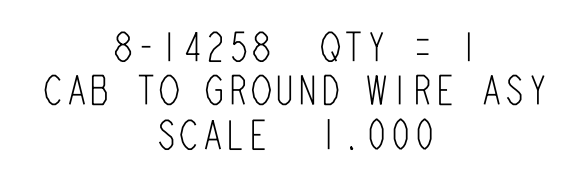
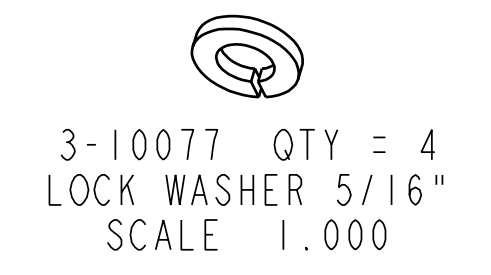
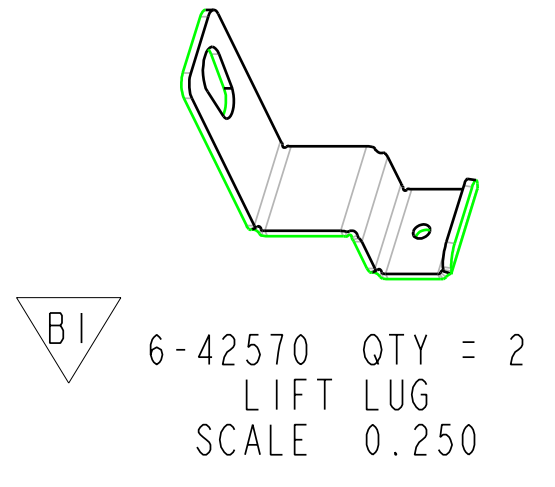
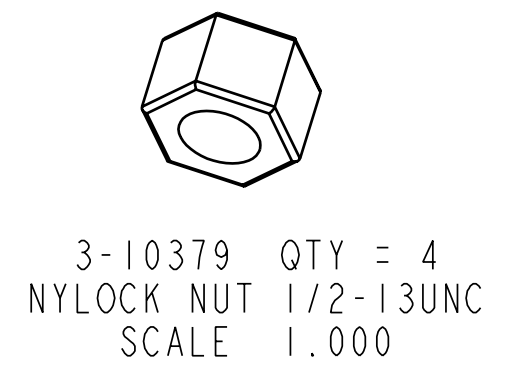
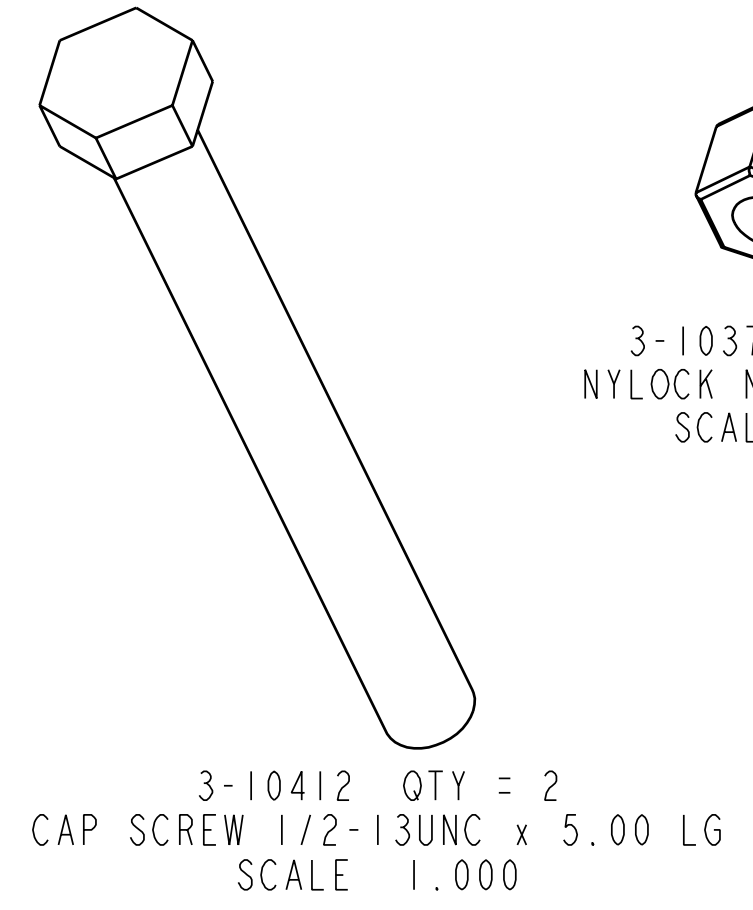
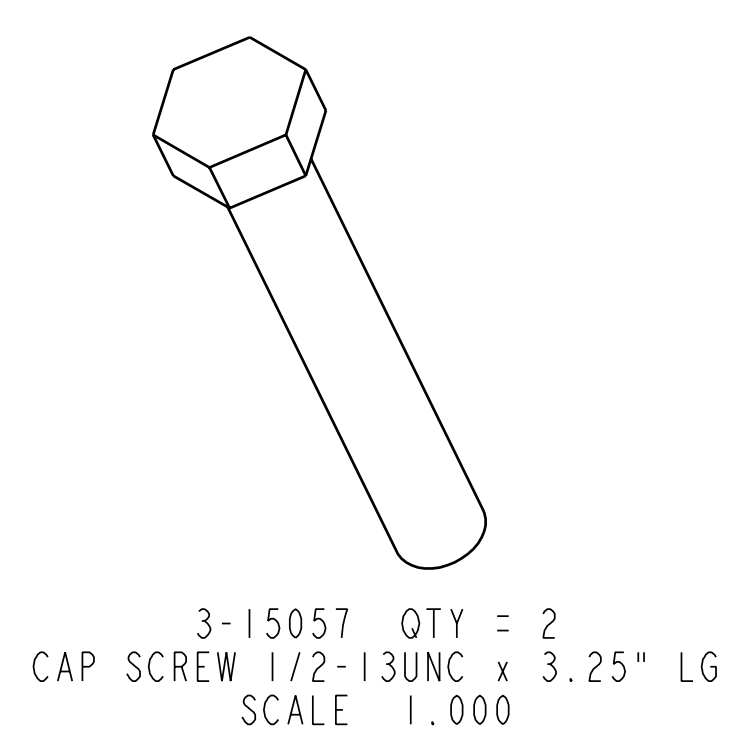
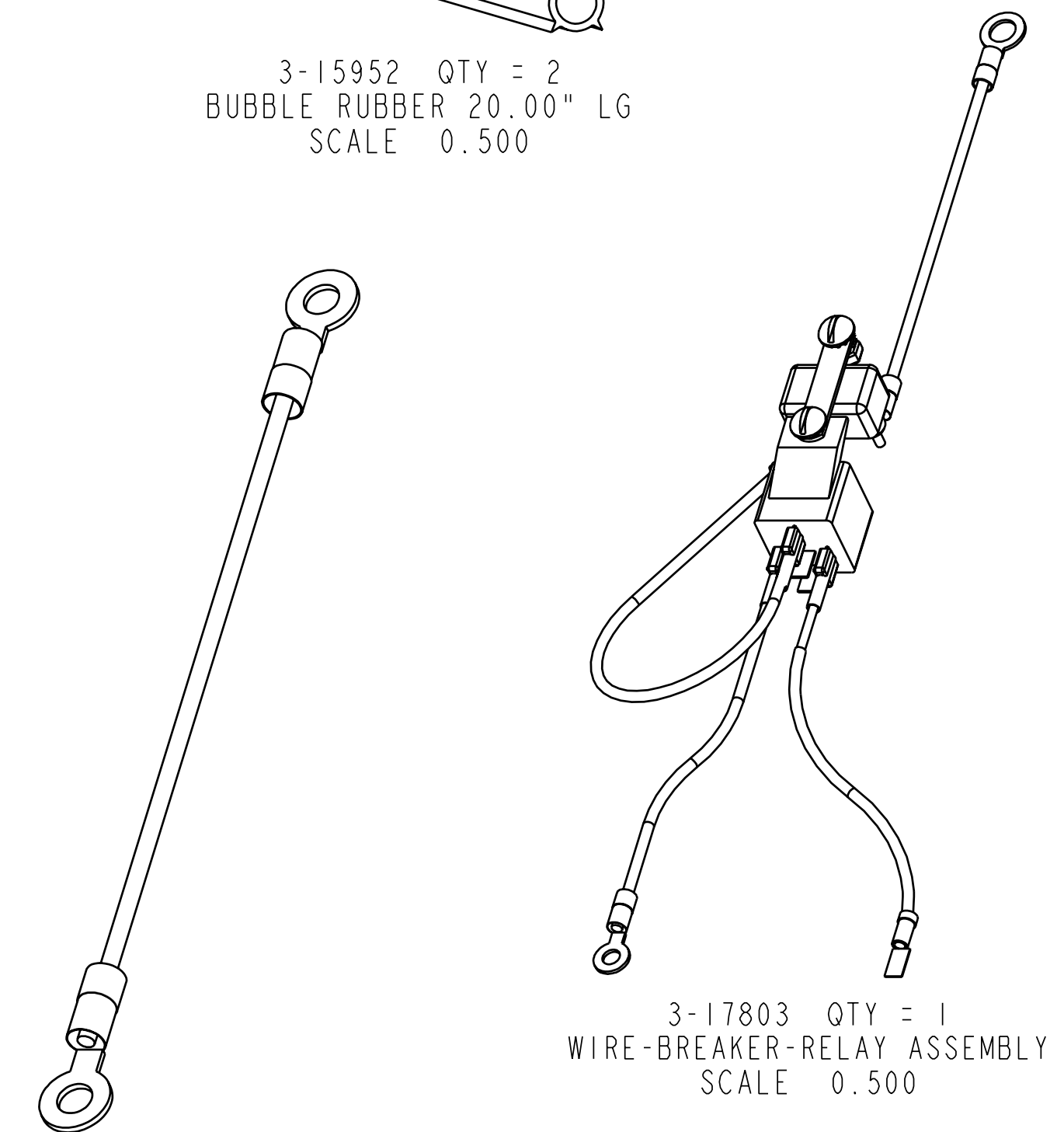
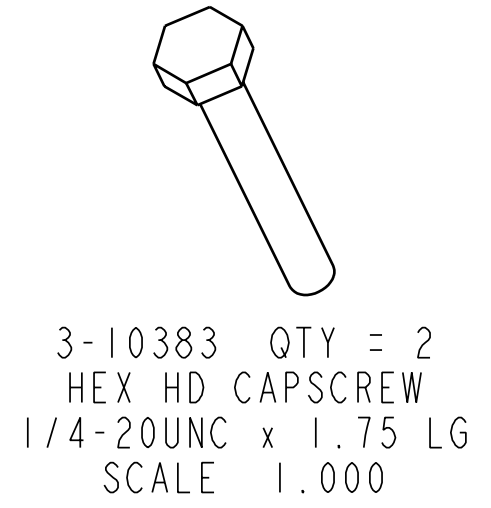
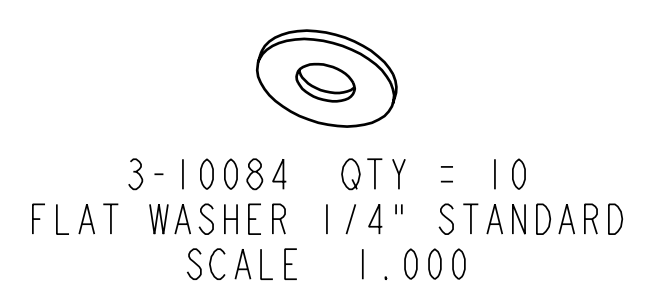
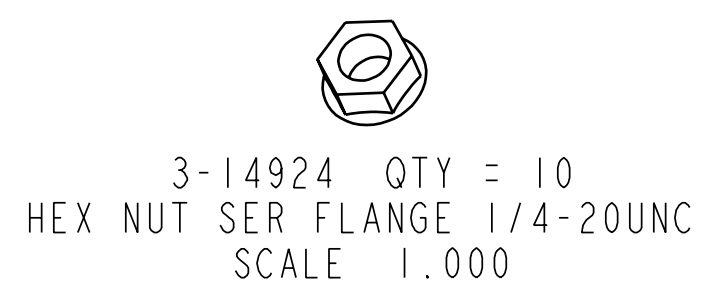
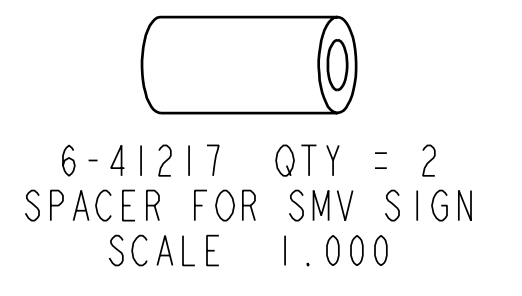
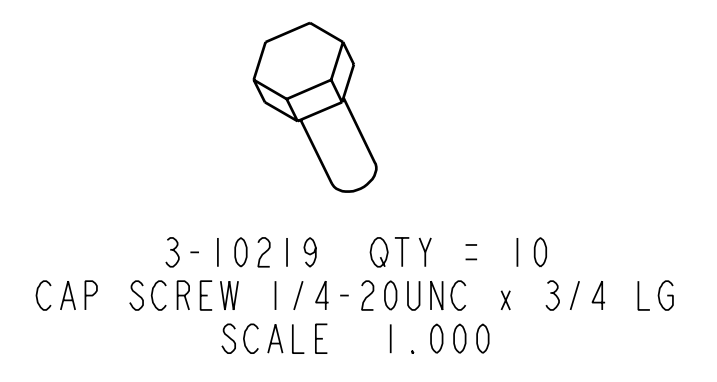
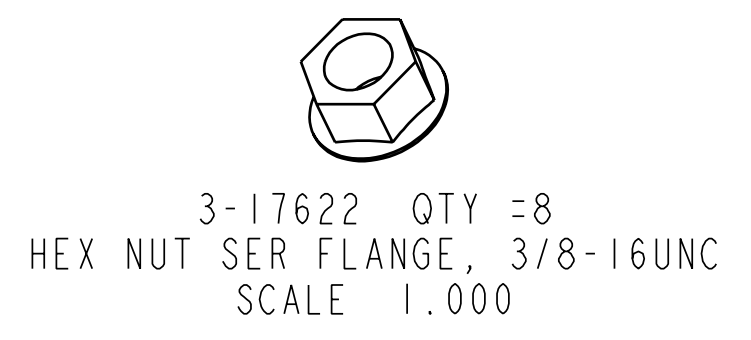
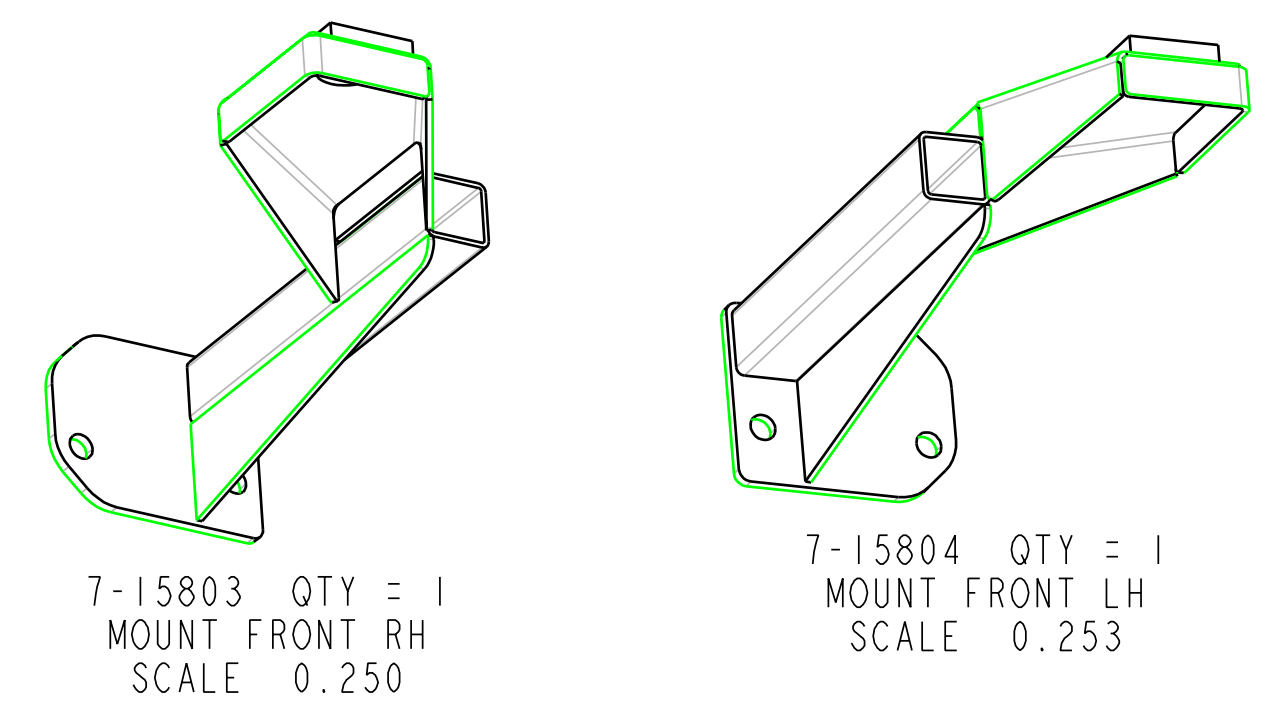
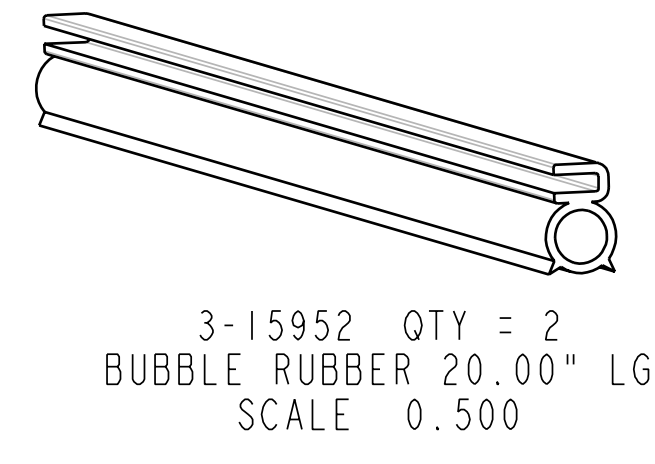
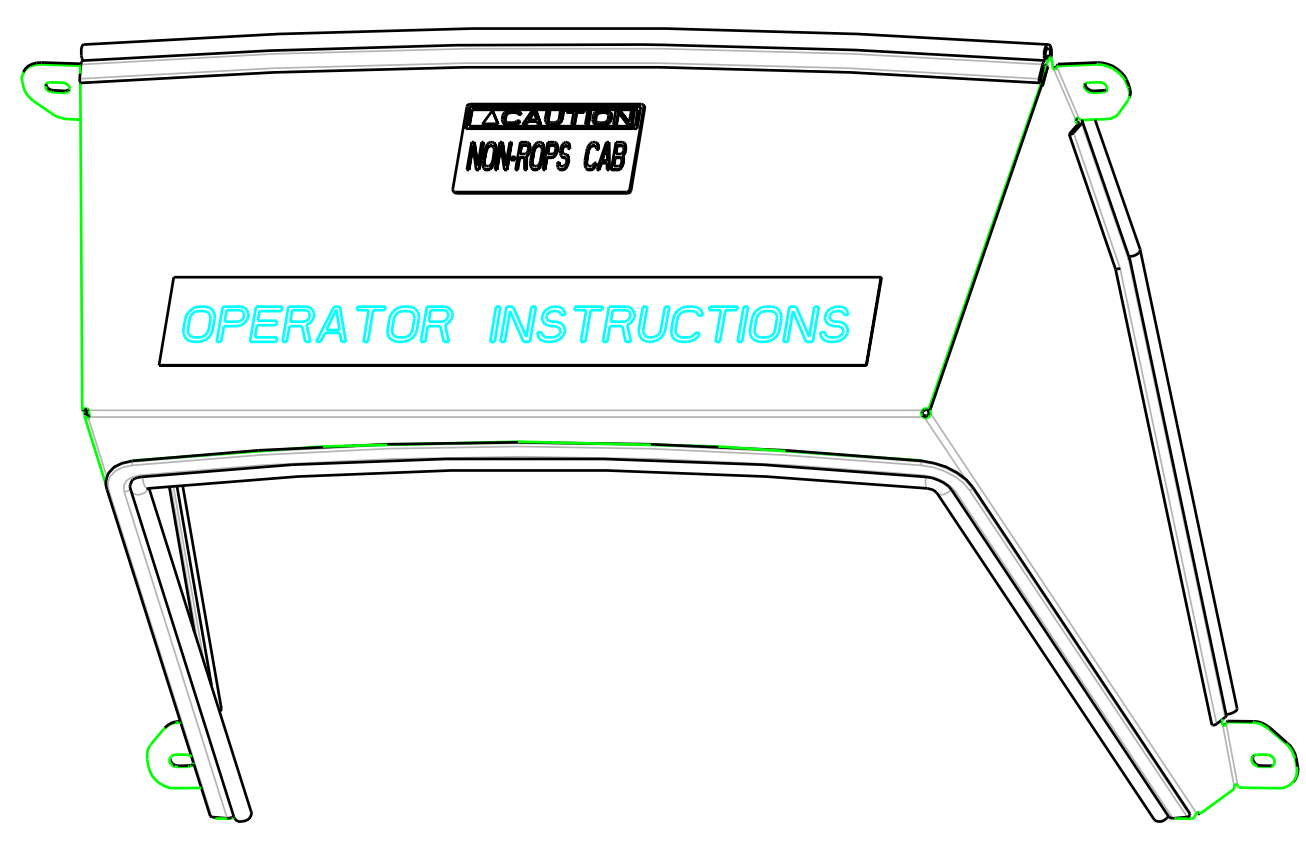
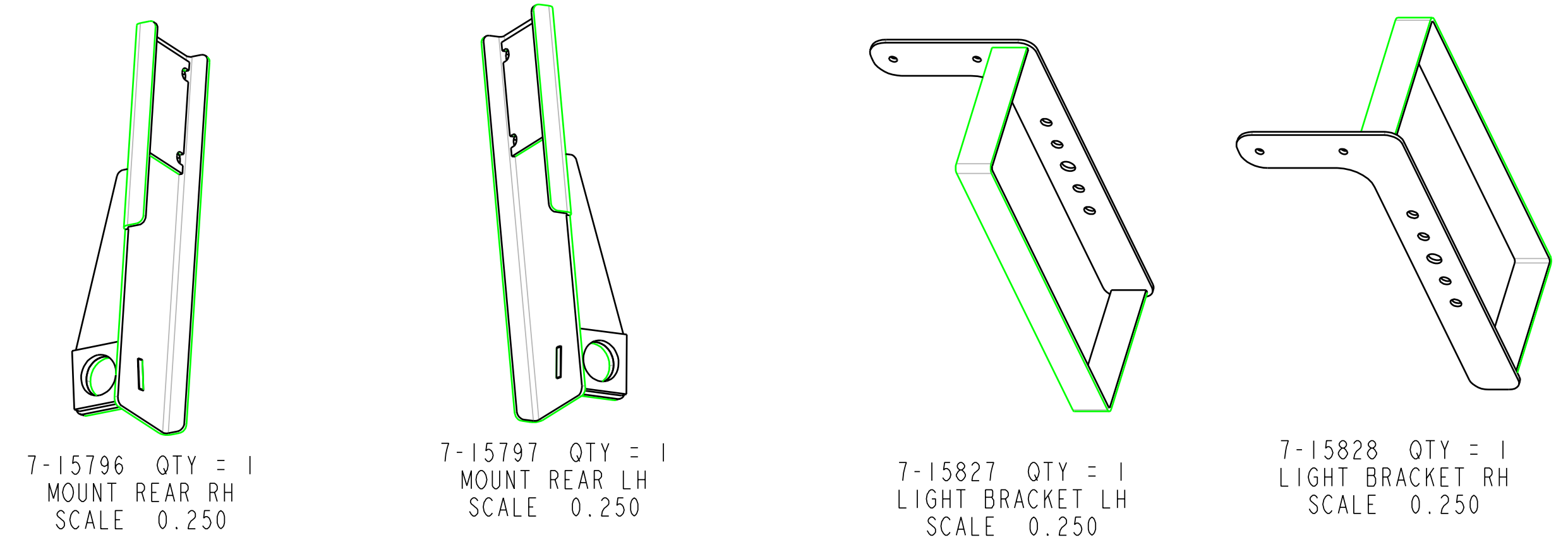

REF HEATER KIT 8-14751 (NOT SHOWN)
REF MOUNTING INSTRUCTIONS MANUAL 05-10433 (NOT SHOWN)
REF BOX 3-17260 (NOT SHOWN) 10 x 30 x 32

THIS DOCUMENT CONTAINS CONFIDENTIAL INFORMATION AND IS THE PROPERTY OF CUSTOM PRODUCTS OF LITCHFIELD, INC. AND MAY NOT BE COPIED, REPRODUCED OR DISCLOSED IN ANY MANNER WITHOUT EXPRESSED WRITTEN CONSENT FROM CUSTOM PRODUCTS OF LITCHFIELD, INC.

TOLERANCES UNLESS NOTED OTHERWISE	CUSTOMER NAME & MOD NO.	MATL SPEC.	SEE BOM
	CUSTOM PRODUCTS 1715 SOUTH SIBLEY AVE LITCHFIELD, MN 55355		
X ± .09 XX ± .06 XXX ± .03 HOLE SIZE .05/.00 ANGLE ± 5°	TITLE MOUNT KIT JD 2210	DRWG NO. D	REV LEVEL 8-14707 1 of 1 D
	DRAWN CAD	DATE 4-24-03	

John Deere 2210
Replacement Parts A-11289
8-14486 HEADLINER ASSEMBLY

<u>ITEM</u>	<u>QTY</u>	<u>PART NO.</u>	<u>DESCRIPTION</u>
1	1	7-15491	HEADLINER WELDMENT
2	1	3-16232	DOME LIGHT 12VDC
3	2	3-16984	MACHINE SCREW NO.6-32UNC
4	2	3-12638	LOCK WASHER NO. 6
5	2	3-12637	HEX NUT NO.6-32UNC
6	1	6-40504	BLOWER SW MOUNT PLATE
7	10	3-11812	SELF TAP SCREW NO.10-24 x 5/8" LG
8	1	3-15432	BLOWER SWITCH 3 SP
9	1	3-11173	BLOWER KNOB
10	1	3-11149	PUSH PULL H-VALVE CABLE LEVER
11	1	6-40505	FUSE ACCESS COVER PANEL
12	1	3-15926	FUSE BLOCK 10-SLOT
13	2	3-10099	MACHINE SCREW 10-24UNC ROUND HD SL
14	2	3-10308	NYLOCK NUT 10-24UNC
15	1	3-16580	FUSE 30 AMP
16	1	3-16851	FUSE 7.5 AMP
17	1	3-16852	FUSE 2 AMP
18	2	3-16057	FUSE 10 AMP
19	1	6-40506	ROCKER SWITCH MOUNT PLATE
20	3	3-16274	ROCKER SWITCH 12VDC
21	2	3-16677	ROCKER SWITCH HOLE PLUG
22	4	3-10729	MACHINE SCREW PHIL HD
23	2	3-10730	GROMMET 1.375 DIA
24	3	3-15594	LOUVER 3" ROUND SNAP-FIT
26	2	3-15928	LOUVER 3" ROUND WIRE-CLIP
27	1	3-15935	BLOWER UNIT
27A	2	3-11202	BLOWER GASKET
28	1	3-10105	MACHINE SCREW NO.10 x 3/4" LG
29	1	3-16572	HEATER CORE
30	2	3-16672	RETAINING CLIP
31	1	3-16692	H-VALVE
32-37	1	3-11172	HEATER HOSE, 5/8" ID
38	2	3-10282	HOSE ELBOW, 90 DEG
39	10	3-10858	HOSE CLAMP NO. 10
40	1	6-41511	POLYFOAM
41	1	6-41512	POLYFOAM
42	1	6-41513	POLYFOAM
43	1	6-41514	POLYFOAM
44	1	6-41515	POLYFOAM
45	1	6-43189	BLOWER SEAL PANEL
46	4	3-16600	NUTSERT 10-24UNC
47	1	6-43190	POLYFOAM FOR BLOWER SEAL PANEL
48	4	3-14927	SERRATED FLANGED SCREW NO.10-24x.625
49	1	8-14376	WIRE SCHEMATIC DIAGRAM

REV.	DCR NO.	DESCRIPTION	DRAFTSMAN	DATE
A	7635	ADDED 3-10834, 2 STRIPS .3125 X 1.00 X 17.00"	JLT	5/31/02
B	7636	REPLACED 3-10088 WITH 3-12638 (2)	JLT	6/05/02
C	-	ADDED ITEMS 45-49	CAD	7/17/03
D	8270	ADDED HOSE NOTES	CAD	11/8/04

NOTE: HOT-PRESSURE TO TOP OF H-VALVE
FROM FRONT RIGHT CAB TUBE A-11289 JD 2210 OR
FROM FRONT LEFT CAB TUBE A-11219 KUBOTA

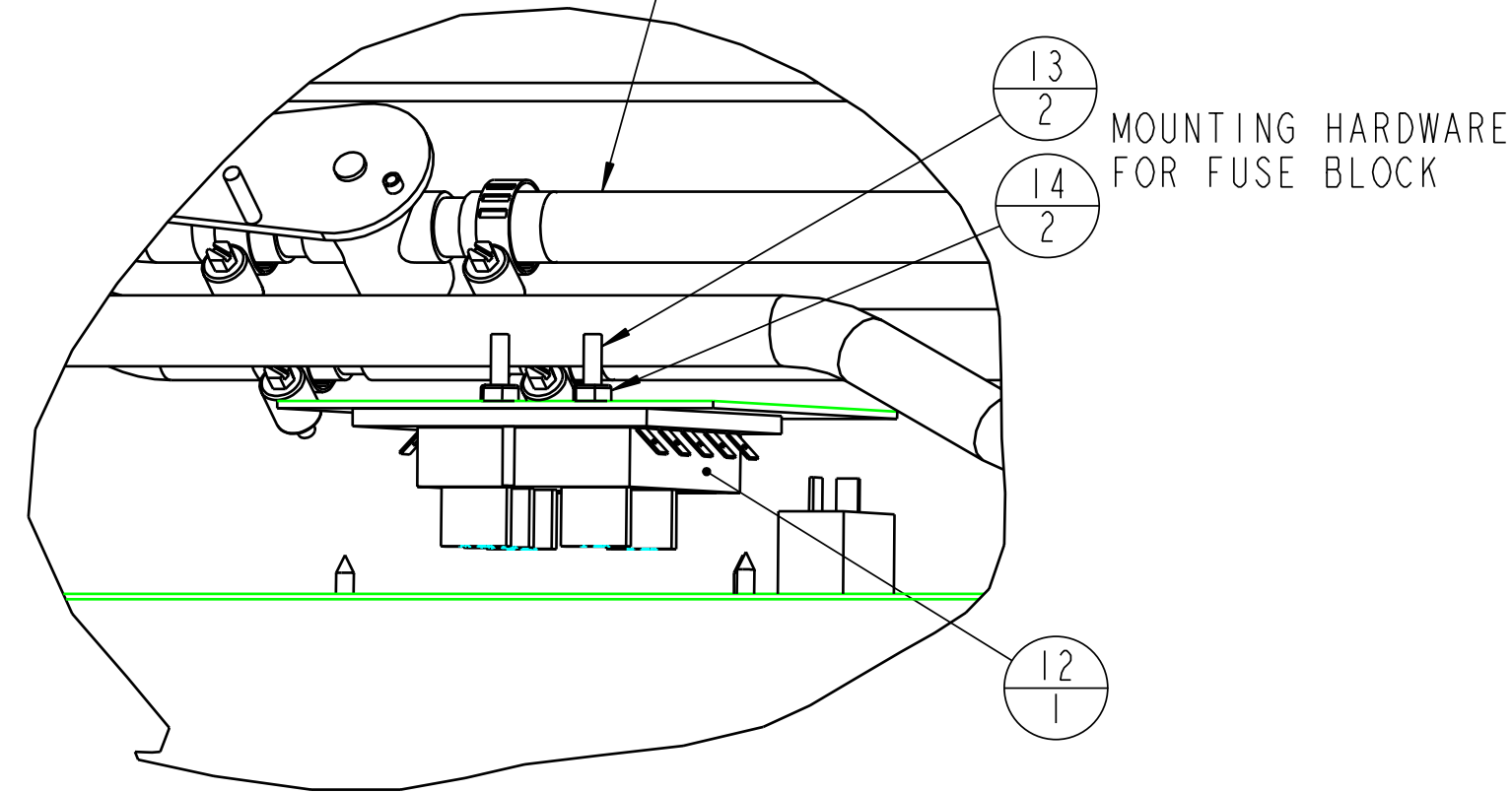

DETAIL A
SCALE 0.500

HOT-PRESSURE (TOP H-VALVE TO TOP OF HEATER CORE)

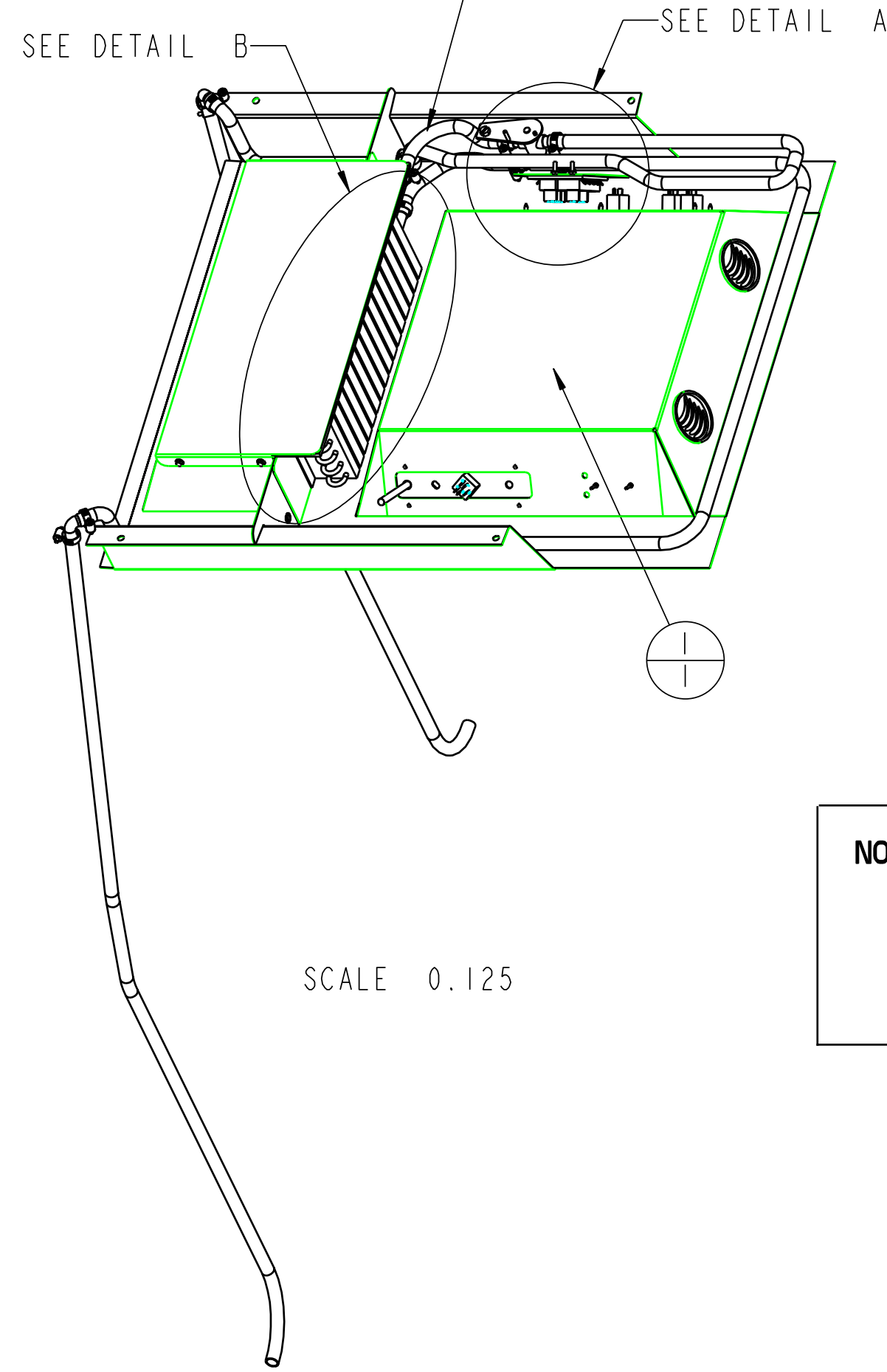

SCALE 0.125

NOTE:
APPLY 3-10834, 2 STRIPS
.3125 X 1.00 X 17.00"
BETWEEN HEADLINER AND
HEATER CORE.

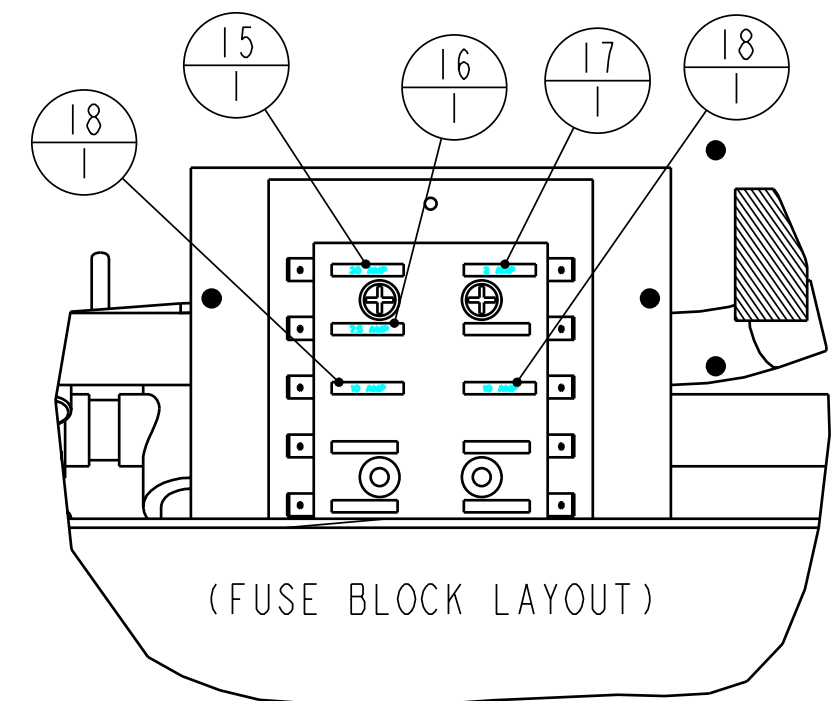

SECTION H-H
SCALE 0.500

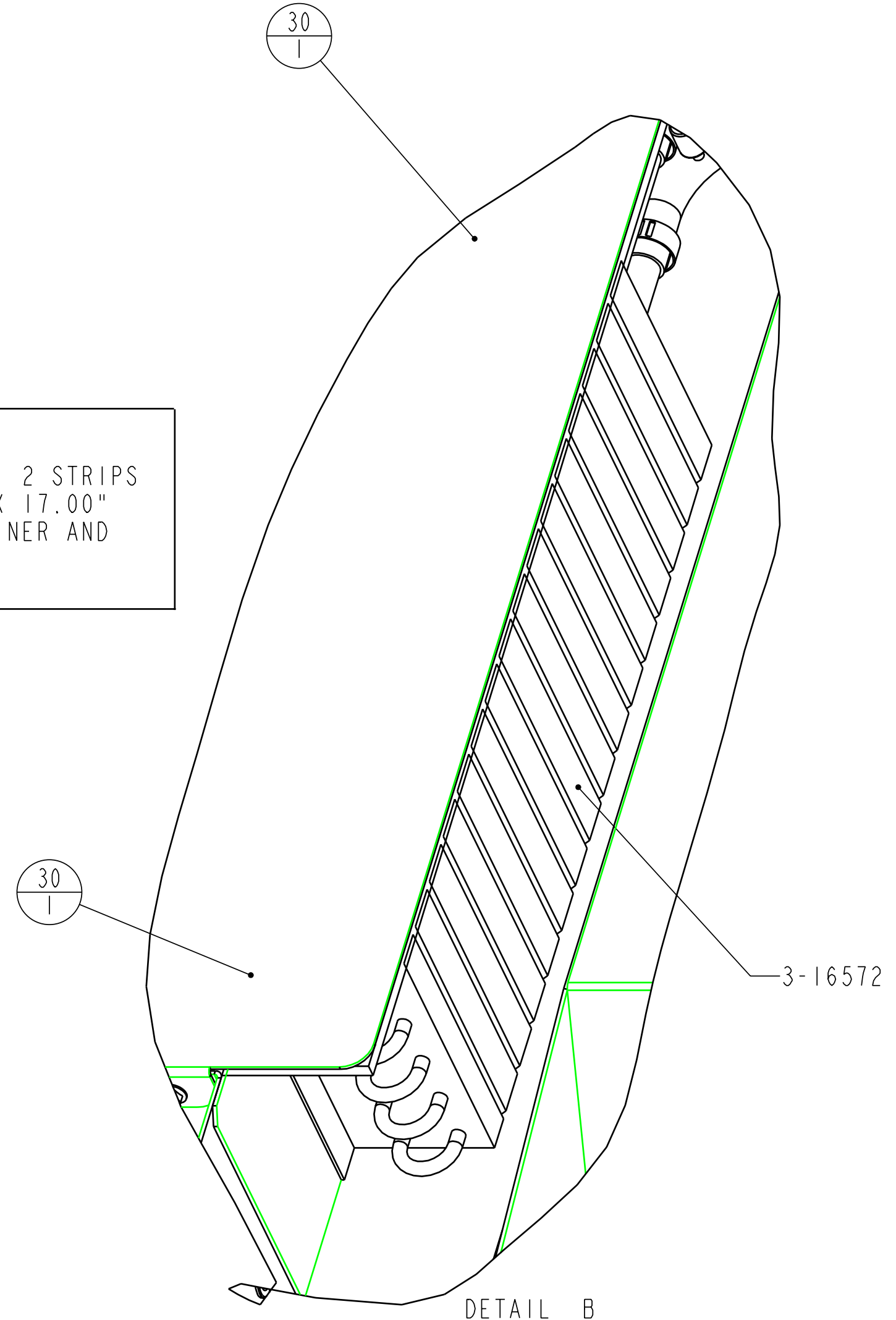

DETAIL B
SCALE 0.500

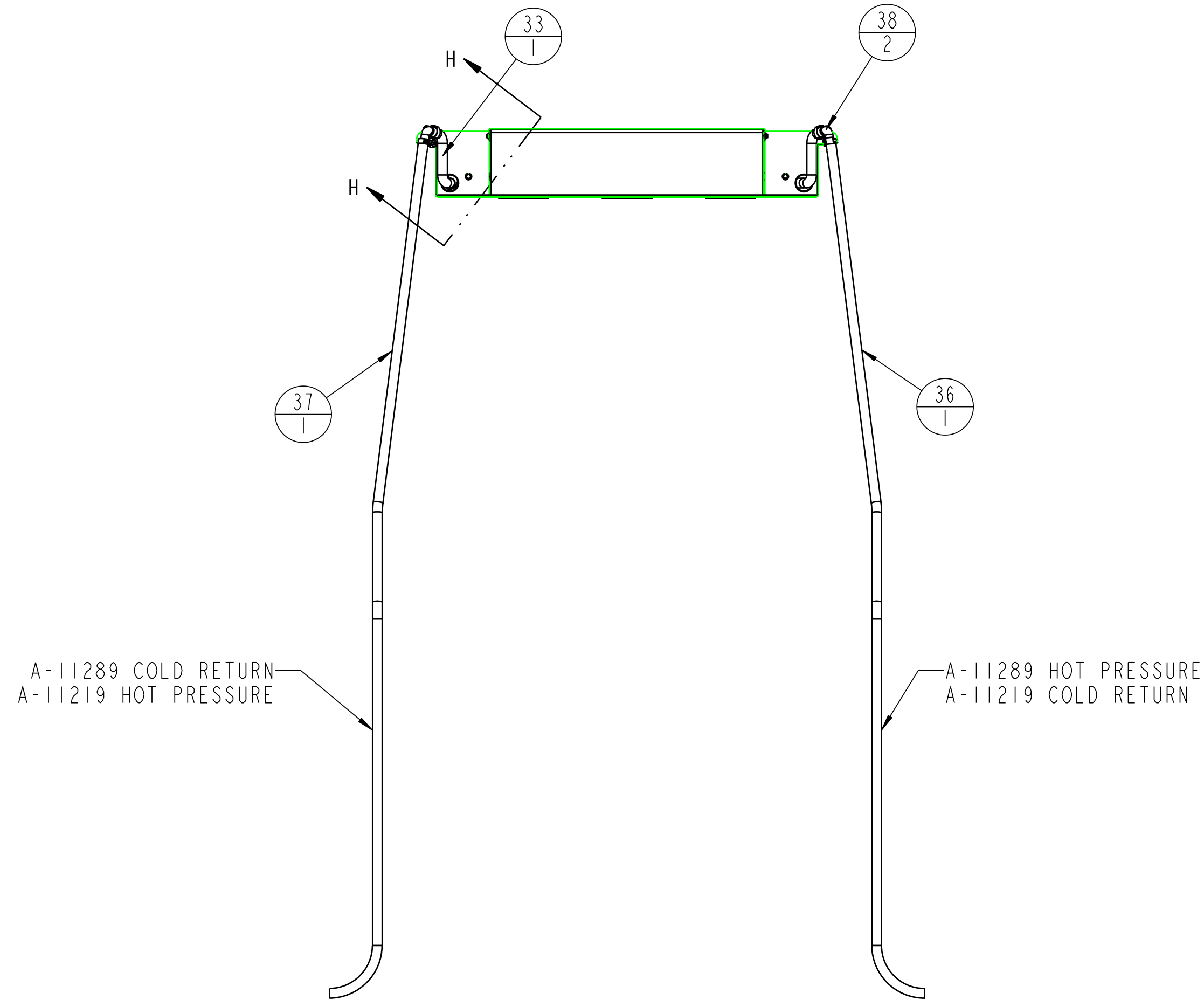

A-11289 COLD RETURN
A-11219 HOT PRESSURE

A-11289 HOT PRESSURE
A-11219 COLD RETURN

SCALE 0.125

NOTES:
REFER TO DRAWING 4-14376 FOR ELECTRICAL DETAILS
REF LONG WIRE HARNESS 3-17503
REF SHORT WIRE HARNESS 3-17504

ID NUMBER	CUSTOMER-MODEL	QTY REQ'D
A-11219	KUBOTA BX	1
A-11289	JD 2210 CAB	1

BALLOON INFORMATION

ITEM NO.	QTY

TOLERANCES UNLESS NOTED OTHERWISE		CUSTOMER NAME & MOD NO: COMMON		MATERIAL SPEC:	
X ± .09 XX ± .06 XXX ± .03 HOLE SIZE 1/16" ± .00 ANGLE ± 5°		CUSTOM PRODUCTS 1715 SOUTH SIBLEY AVE LITCHFIELD, MN 55355		DRAWN: TEO DATE: 6/25/01 1 of 2	
TITLE: ASSEMBLY, HEADLINER		DRWG NO: D	8-14486	REV LEVEL: D	

NAME: CAD2 OBJECT: 8-14486_1 DATE: 09-Nov-04 10:07:48

REV.	DCR NO.	DESCRIPTION	DRAFTSMAN	DATE
A	7635	SEE SHEET 1	JLT	5/31/02
B	7636	REPLACE 3-10088 WITH 3-12638 (2)	JLT	6/05/02
C	-	SEE SHEET 1	CAD	7-18-03
D	8270	SEE SHEET 1	CAD	11-8-04

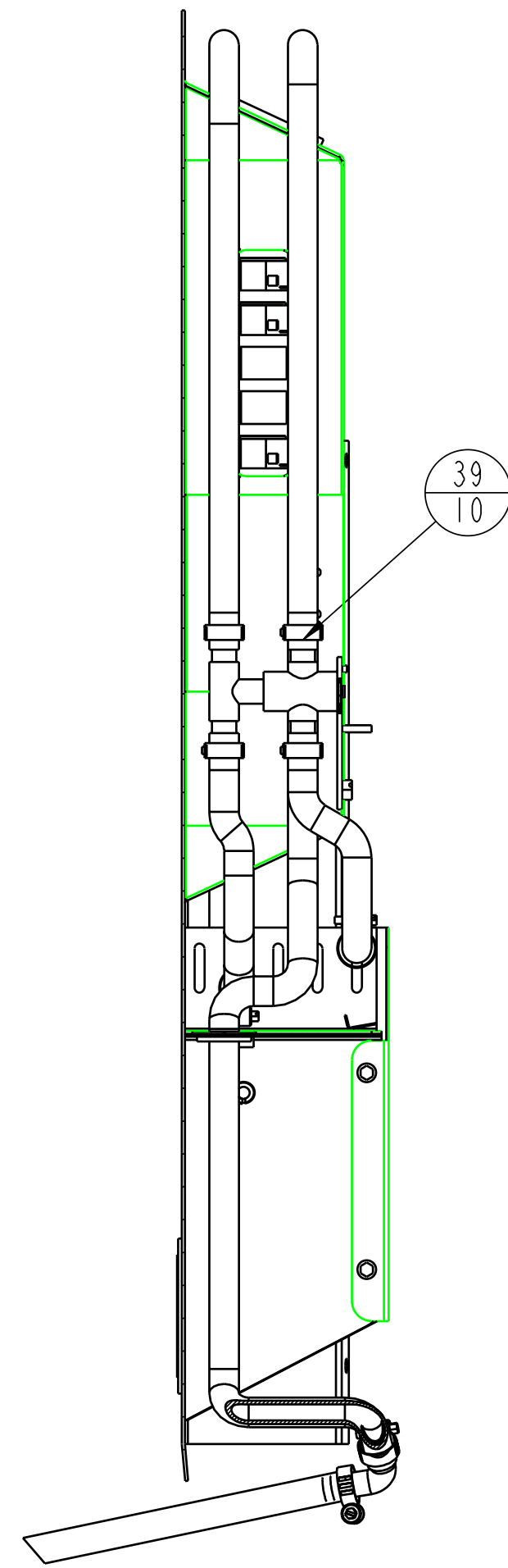

SECTION B-B
SCALE 0.250

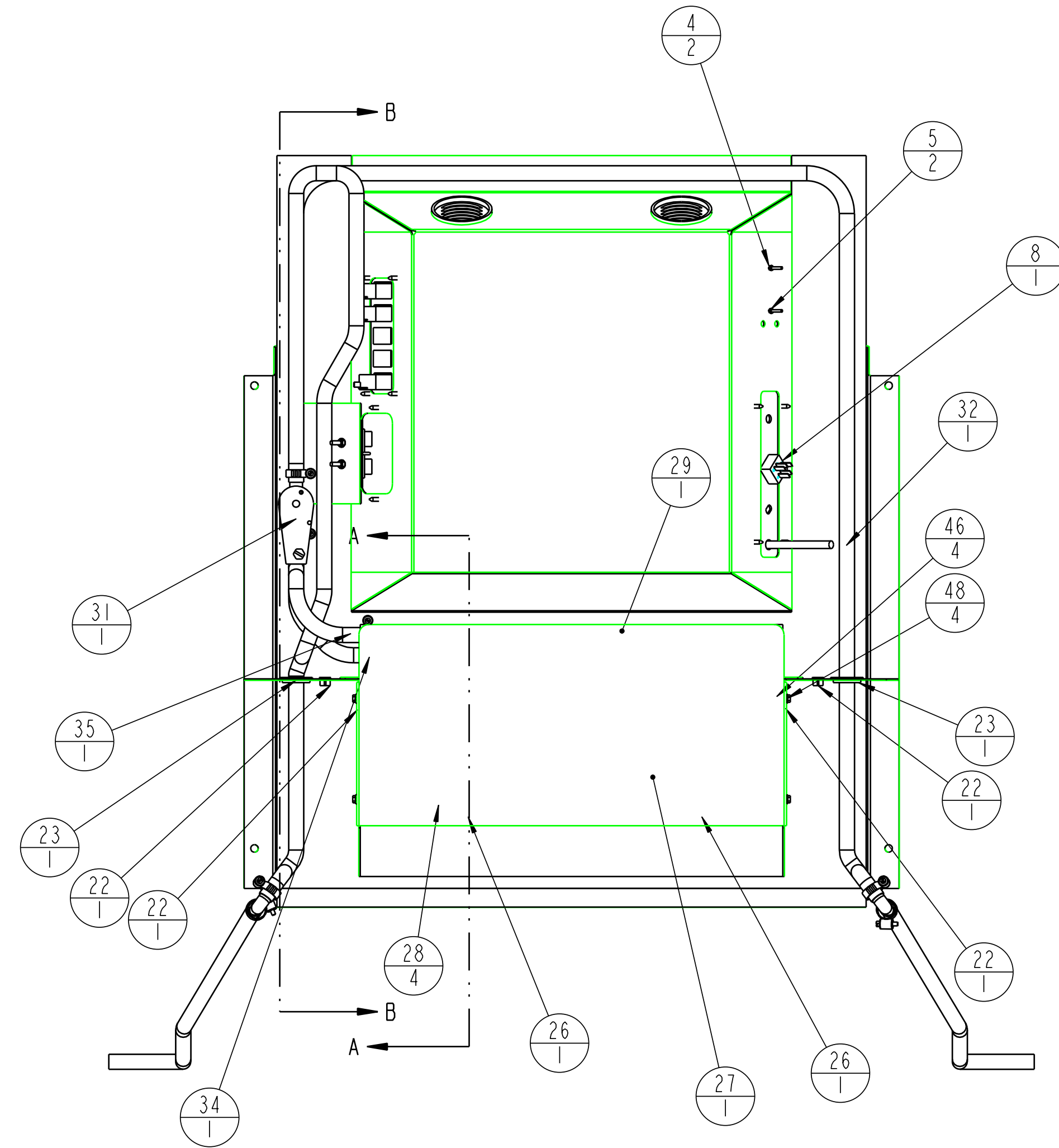

NOTE REF:
 A-11289 JD 2210 LH FRONT TUBE HOSE ROUTES TO TOP OF H-VALVE
 A-11219 KUBOTA RH FRONT TUBE HOSE ROUTES TO TOP OF H-VALVE

SCALE 0.188

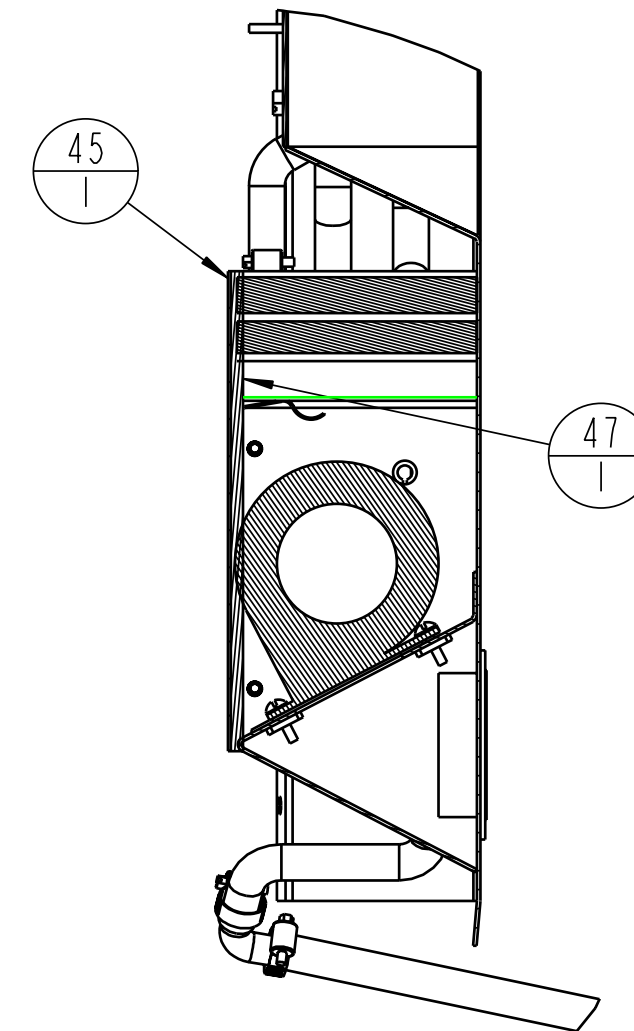

SECTION A-A
SCALE 0.250

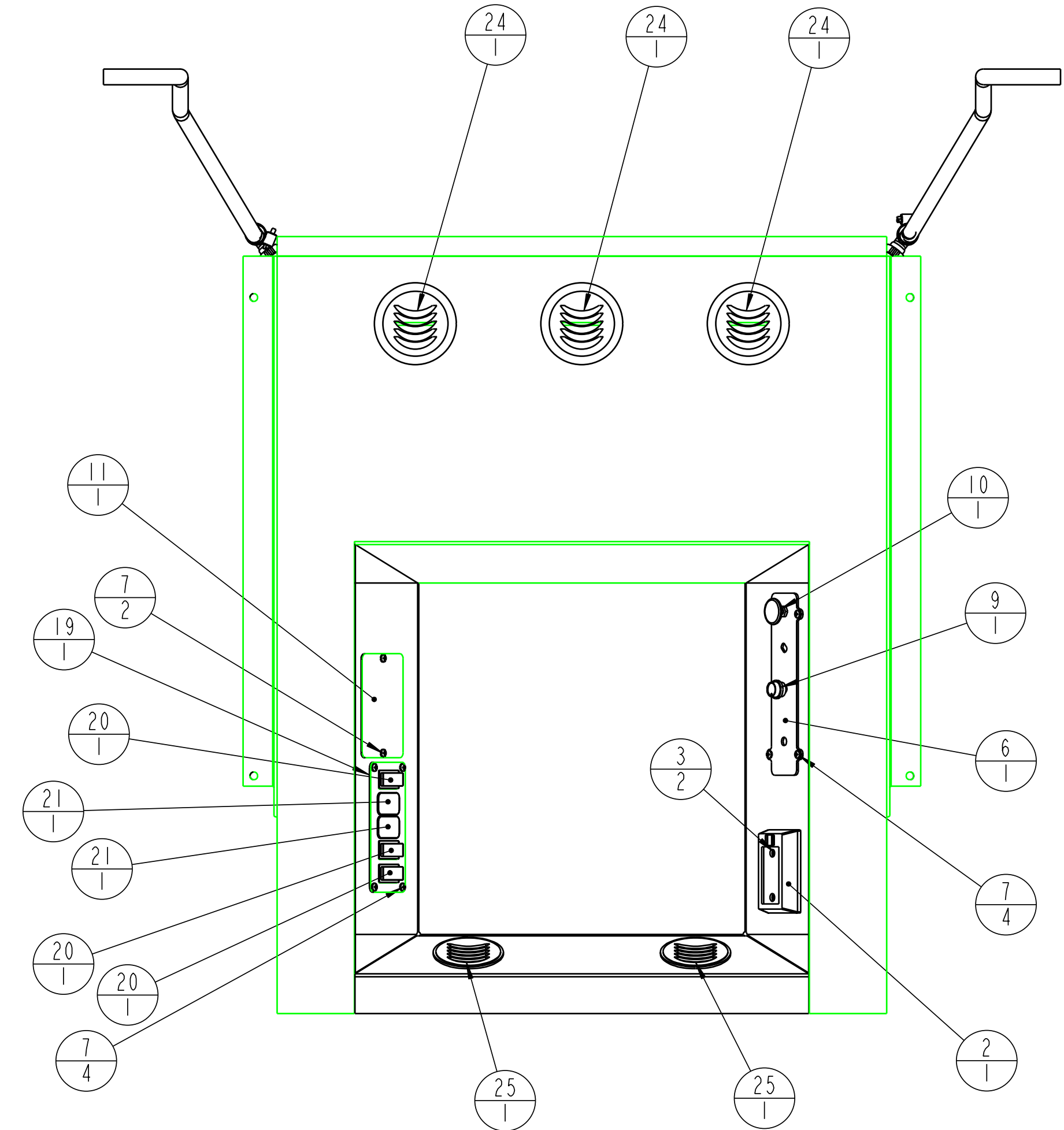

SCALE 0.188

NAME: CAD2 OBJECT: 8-14486-2 DATE: 09-Nov-04 10:09:41

THIS DOCUMENT CONTAINS CONFIDENTIAL INFORMATION AND IS THE PROPERTY OF CUSTOM PRODUCTS OF LITCHFIELD, INC. AND MAY NOT BE COPIED, REPRODUCED OR DISCLOSED IN ANY MANNER WITHOUT EXPRESSED WRITTEN CONSENT FROM CUSTOM PRODUCTS OF LITCHFIELD, INC.

TOLERANCES UNLESS NOTED OTHERWISE: X ± .09 JXX ± .06 JXXX ± .03 HOLE SIZE 1/64 ± .00 ANGLE ± 5°	CUSTOMER NAME & MOD NO: see sht 1		MATL SPEC:	
	CUSTOM PRODUCTS 1715 SOUTH SIBLEY AVE LITCHFIELD, MN 55355		DRAWING SIZE: D	DRAWING NO: 4-14486
TITLE: ASSEMBLY, HEADLINER			REV LEVEL: D	DRAWN: TEO DATE: 6/25/01 2 of 2

John Deere 2210
Replacement Parts A-11289
8-14708 DOOR ASSEMBLY LH

<u>ITEM</u>	<u>QTY</u>	<u>PART NO.</u>	<u>DESCRIPTION</u>
1	1	7-15799	DOOR WELDMENT LH
2	4	3-13630	HEX HEAD CAP SCREW M6x1x1
3	7	3-10076	LOCK WASHER, 1/4"
4	3	3-13630	HEX HEAD CAP SCREW M6x15x1
5	1	3-11821	BALL STUD FOR GAS SPRING
6	1	3-10077	LOCK WASHER 5/16"
7	1	3-10064	HEX NUT 5/16-18 UNC
8	1	3-17579	DOOR WINDOW TEMPERED
9	1	3-15952	BUBBLE RUBBER 90 DEG
10	1	3-17742	GRAB HANDLE EXTERIOR
11	1	3-18002	ROTARY LATCH WITH TRIP HANDLE LH
12	1	3-10220	HEX HEAD CAP SCREW 1/4-20UNC x 1 LG
13	1	3-10063	HEX NUT 1/4-20 UNC
14	1	3-16669	WINDOW RUBBER FOR 1/8" GLASS

John Deere 2210
Replacement Parts A-11289
8-14709 DOOR ASSEMBLY RH

<u>ITEM</u>	<u>QTY</u>	<u>PART NO.</u>	<u>DESCRIPTION</u>
1	1	7-15798	DOOR WELDMENT RH
2	4	3-13630	HEX HEAD CAP SCREW M6x1x1
3	7	3-10076	LOCK WASHER, 1/4"
4	3	3-13630	HEX HEAD CAP SCREW M6x15x1
5	1	3-11821	BALL STUD FOR GAS SPRING
6	1	3-10077	LOCK WASHER 5/16"
7	1	3-10064	HEX NUT 5/16-18 UNC
8	1	3-17579	DOOR WINDOW TEMPERED
9	1	3-15952	BUBBLE RUBBER 90 DEG
10	1	3-17742	GRAB HANDLE EXTERIOR
11	1	3-18003	ROTARY LATCH WITH TRIP HANDLE RH
12	1	3-10220	HEX HEAD CAP SCREW 1/4-20UNC x 1 LG
13	1	3-10063	HEX NUT 1/4-20 UNC
14	1	3-16669	WINDOW RUBBER FOR 1/8" GLASS

REV.	DCR NO.	DESCRIPTION	DRAFTSMAN	DATE
-	-	-	-	-

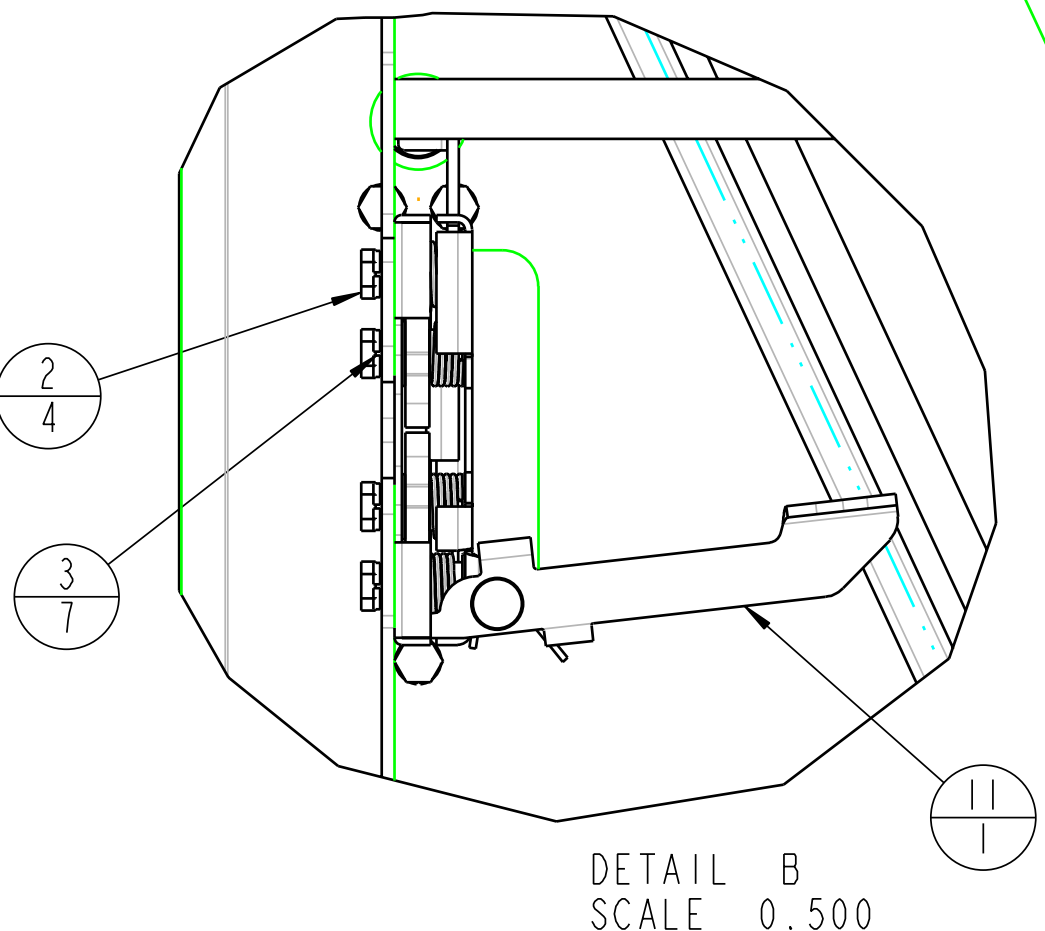
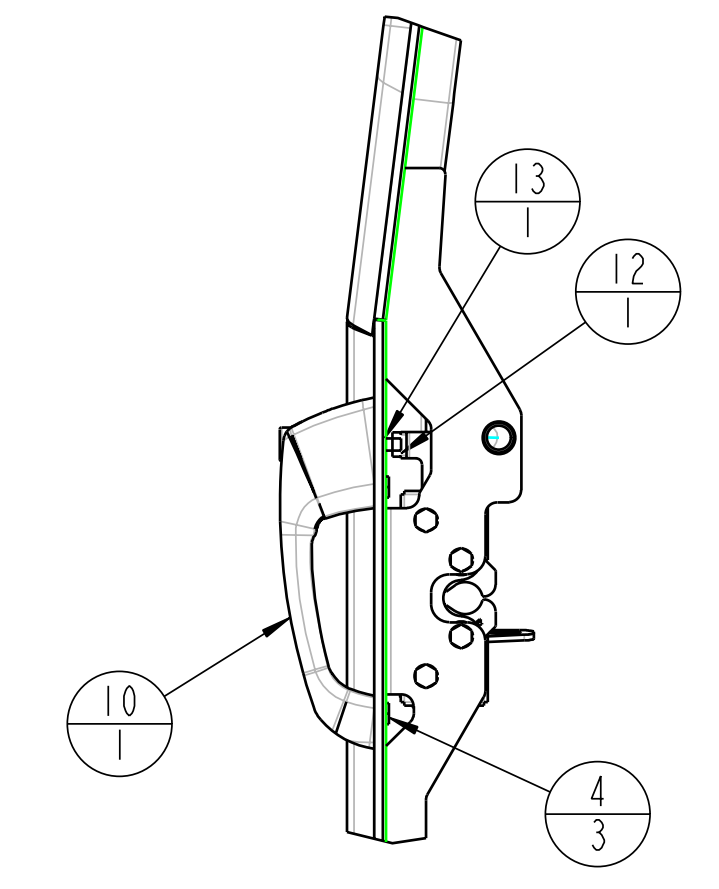
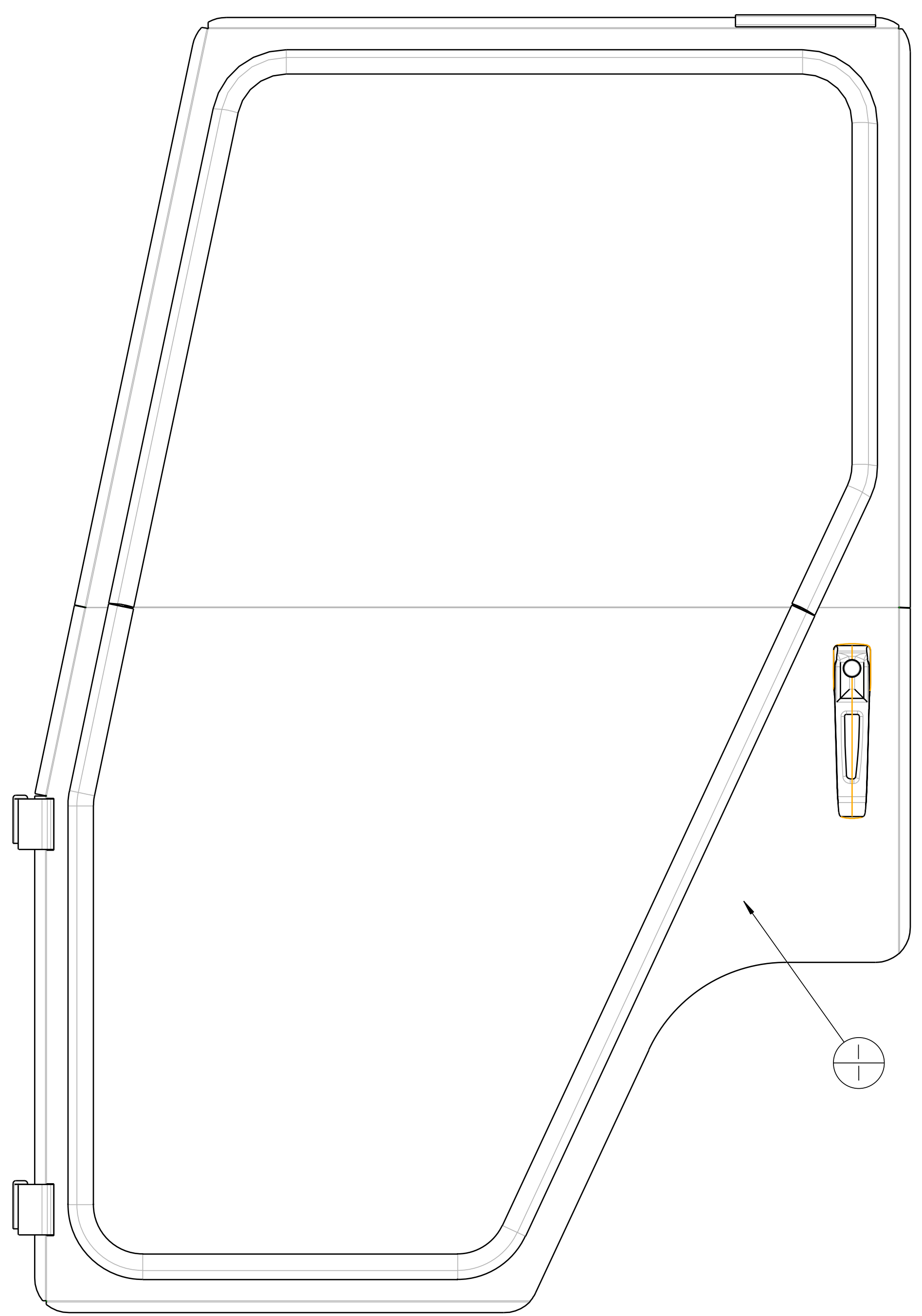
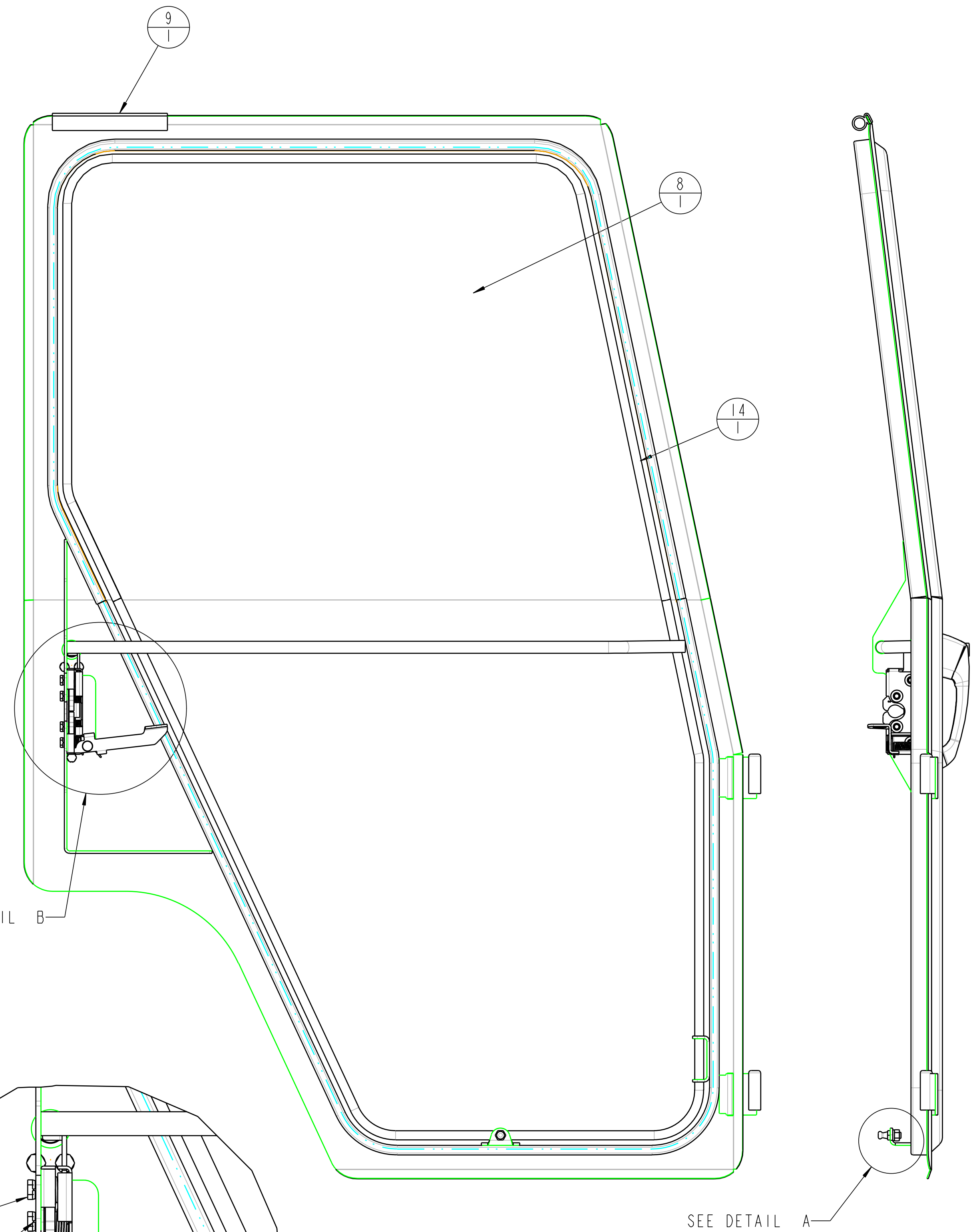

DETAIL B
SCALE 0.500

SEE DETAIL A

SCALE 0.250

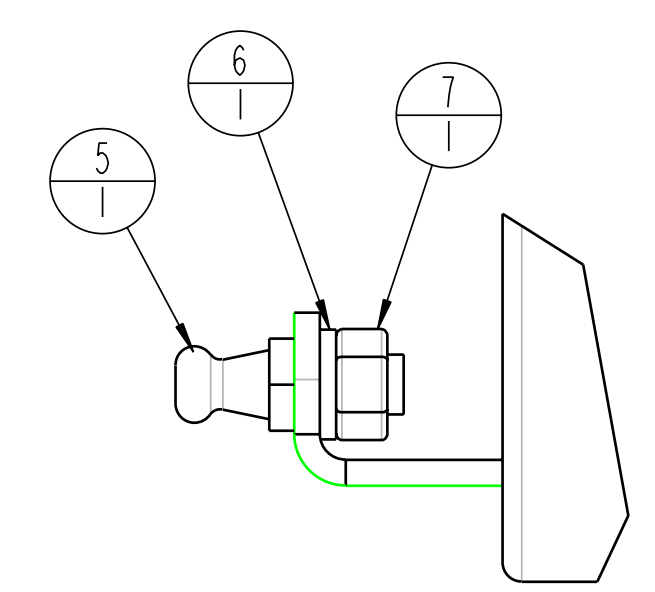

DETAIL A
SCALE 1.000

BALLOON INFORMATION

ITEM NO.	QTY

THIS DOCUMENT CONTAINS CONFIDENTIAL INFORMATION AND IS THE PROPERTY OF CUSTOM PRODUCTS OF LITCHFIELD, INC. AND MAY NOT BE COPIED, REPRODUCED OR DISCLOSED IN ANY MANNER WITHOUT EXPRESSED WRITTEN CONSENT FROM CUSTOM PRODUCTS OF LITCHFIELD, INC.

TOLERANCES UNLESS NOTED OTHERWISE	CUSTOMER NAME & MOD NO.	JD 2210	MATL SPEC.	SEE BOM
	CUSTOM PRODUCTS	1715 SOUTH SIBLEY AVE	LITCHFIELD, MN 55355	
X ± .09 XX ± .06 XXX ± .03 HOLE SIZE /05/.00 ANGLE ± 5°	TITLE	DRWG SIZE	DRWG NO.	REV LEVEL
	DOOR ASSEMBLY LH	D	8-14708 1 of 1	-
	DRAWN	CAD	DATE	7-18-03

REV.	DCR NO.	DESCRIPTION	DRAFTSMAN	DATE
-	-	-	-	-

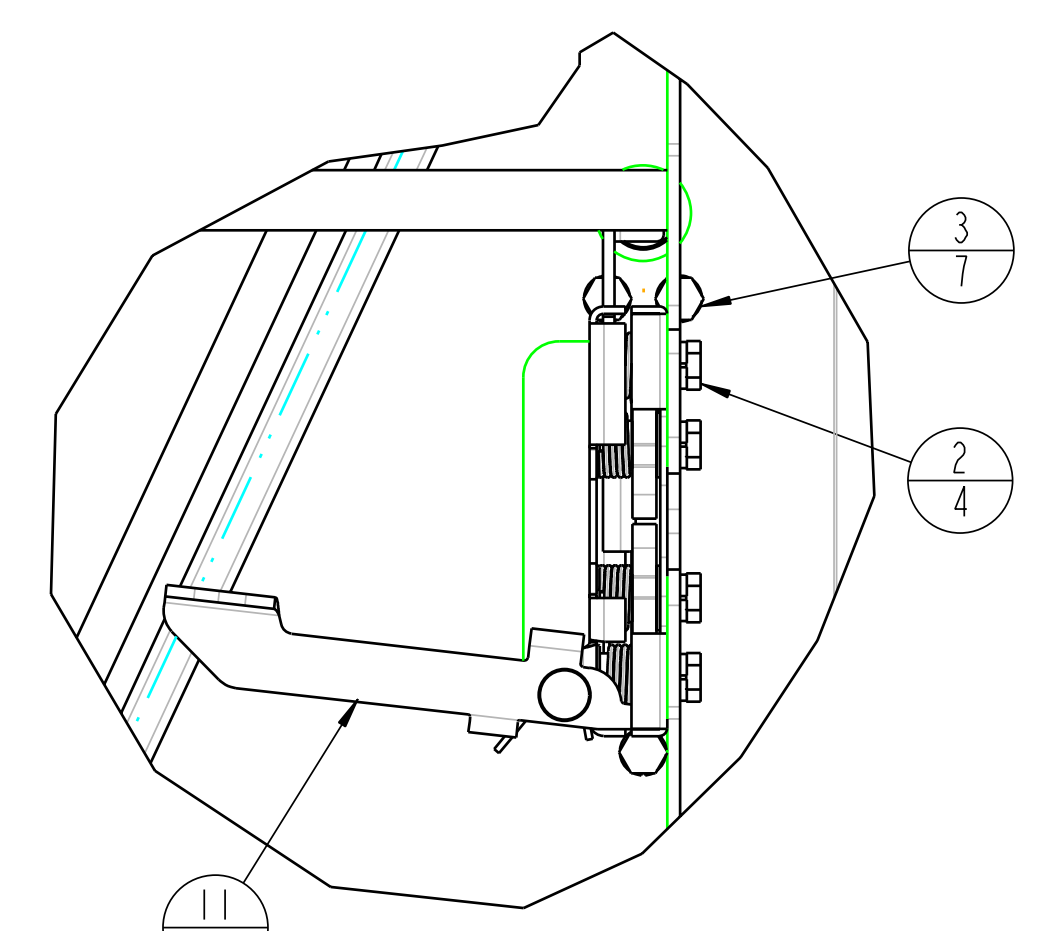
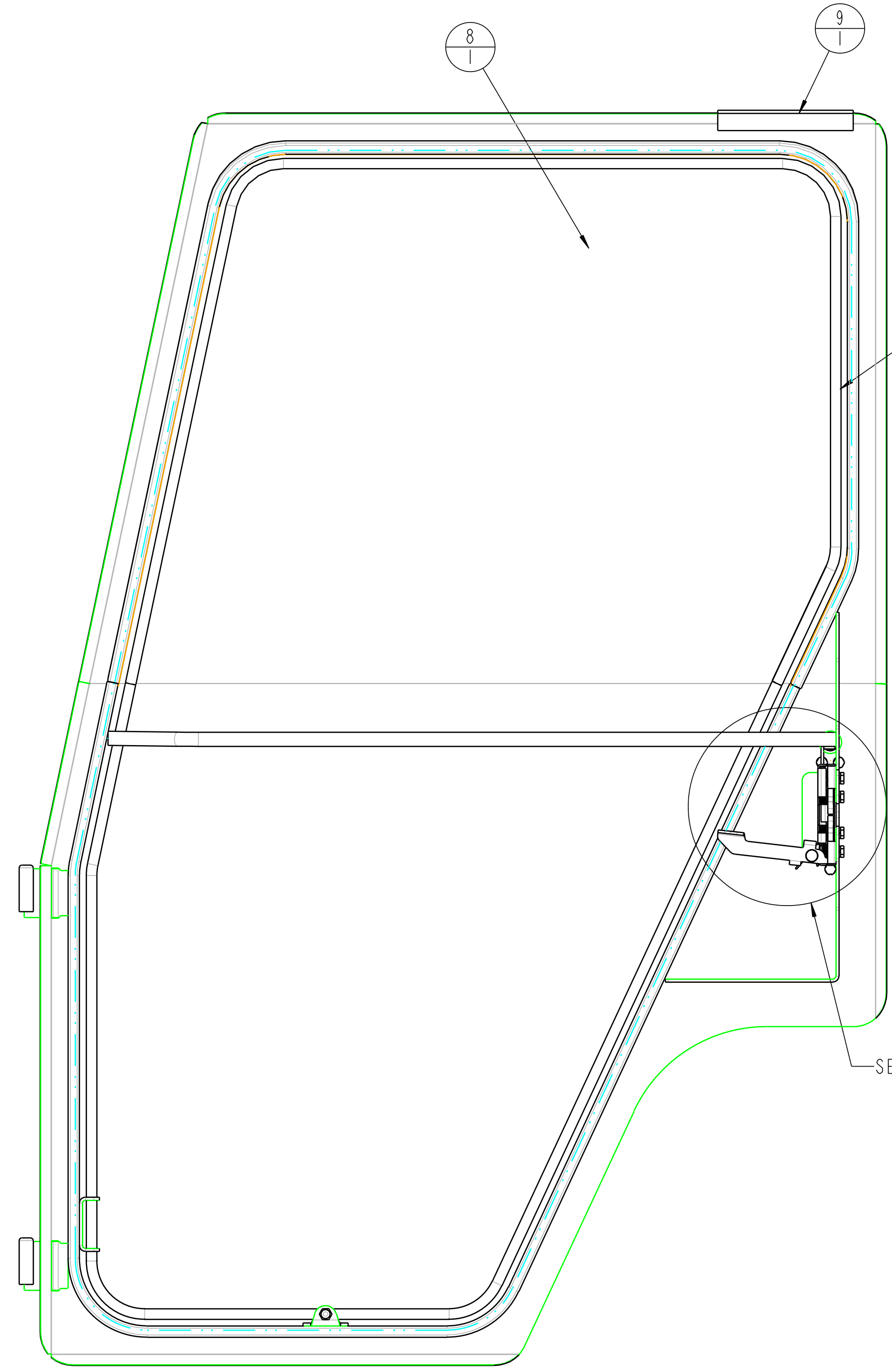
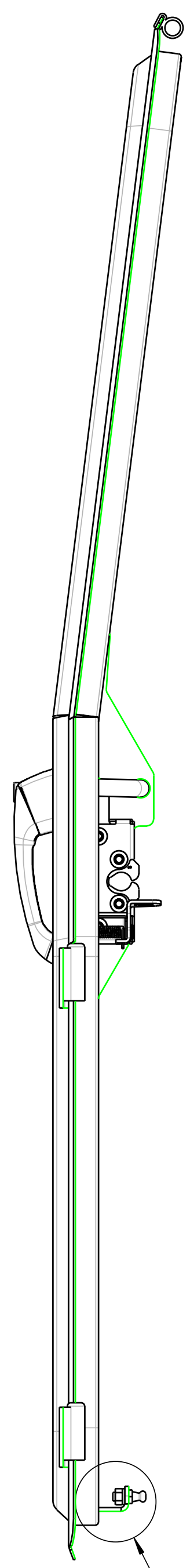
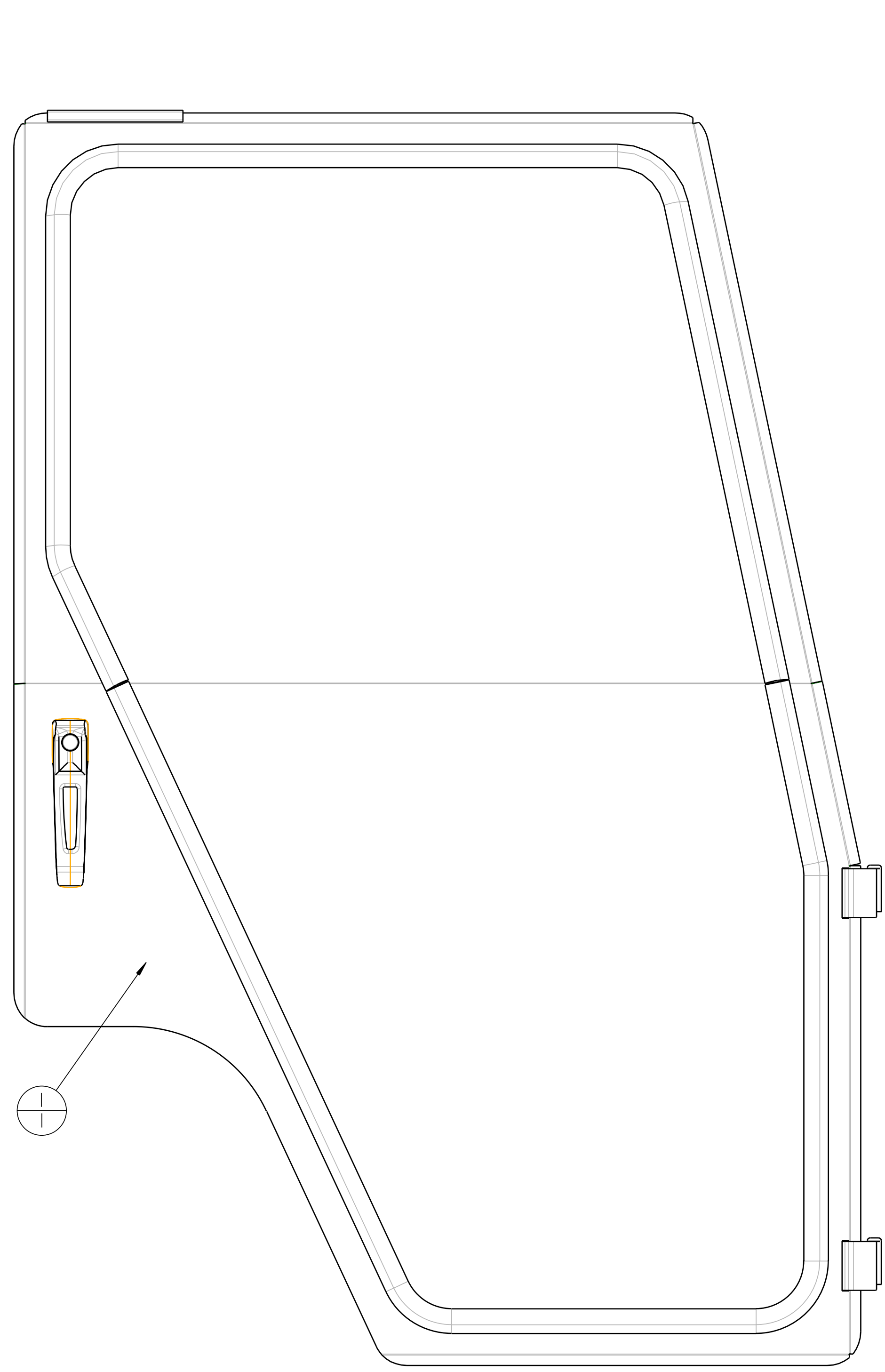

DETAIL B
SCALE 0.500

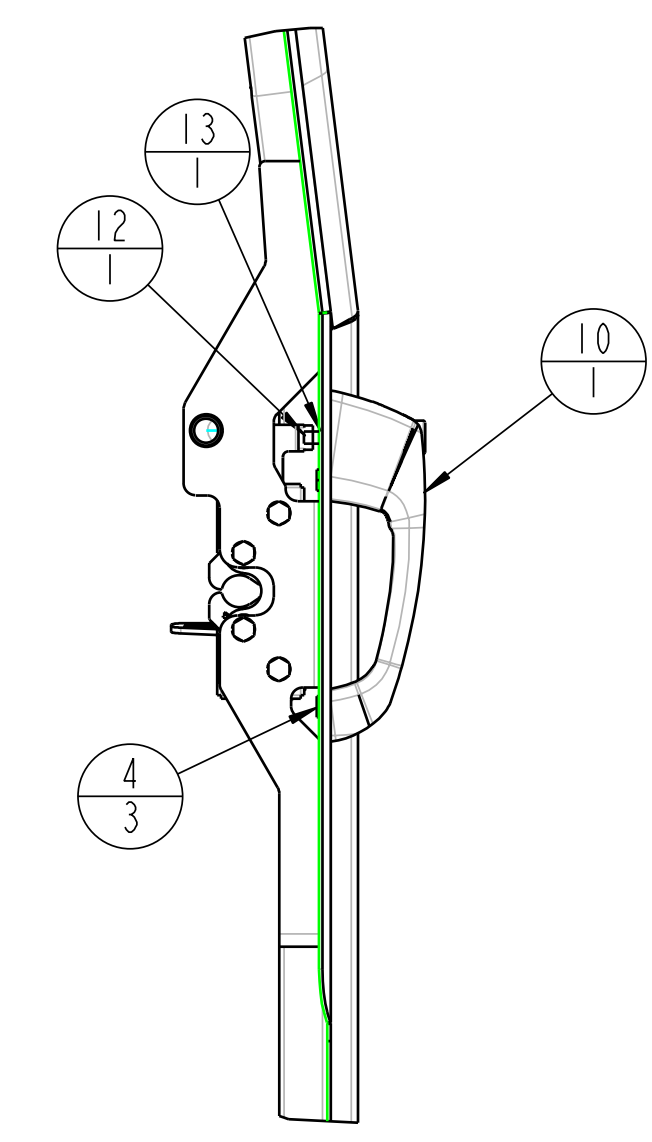

SEE DETAIL B

SEE DETAIL A

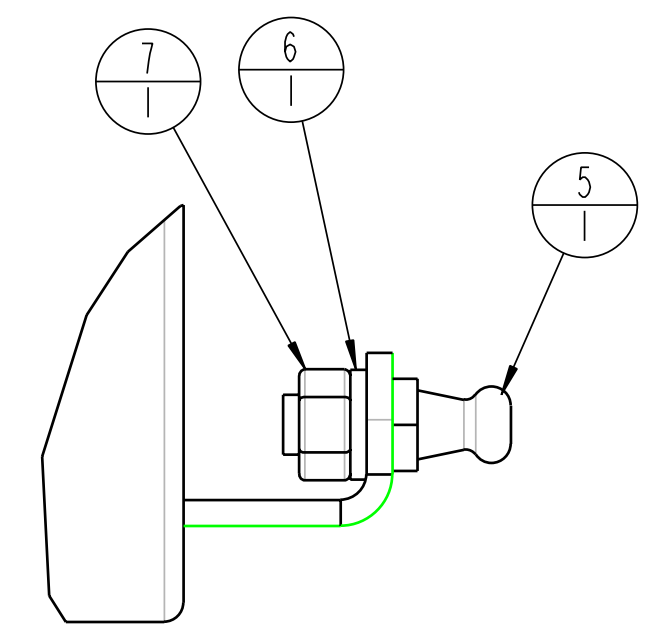

DETAIL A
SCALE 1.000

BALLOON INFORMATION
ITEM NO.
QTY

SCALE 0.250

THIS DOCUMENT CONTAINS CONFIDENTIAL INFORMATION AND IS THE PROPERTY OF CUSTOM PRODUCTS OF LITCHFIELD, INC. AND MAY NOT BE COPIED, REPRODUCED OR DISCLOSED IN ANY MANNER WITHOUT EXPRESSED WRITTEN CONSENT FROM CUSTOM PRODUCTS OF LITCHFIELD, INC.

TOLERANCES UNLESS NOTED OTHERWISE	CUSTOMER NAME & MOD. NO.	JD 2210	MATL. SPEC.	SEE BOM
	CUSTOM PRODUCTS	1715 SOUTH SIBLEY AVE	LITCHFIELD, MN 55355	
X ± .08 .XX ± .06 .XXX ± .03 HOLE SIZE DIA ± .00 ANGLE ± 5°	TITLE	DRWG. SIZE	DRWG. NO.	REV. LEVEL
	DOOR ASSEMBLY RH	D	8-14709 1 of 1	-
	DRAWN	CAD	DATE	7-18-03

John Deere 2210
Replacement Parts A-11289
8-14731 HOOD FOR JD 2210

<u>ITEM</u>	<u>QTY</u>	<u>PART NO.</u>	<u>DESCRIPTION</u>
1	1	7-15824	HOOD WELDMENT
2,3,6 &7	1	3-15068	BUBBLE RUBBER 180 DEG
4	1	3-18071	OPERATIONS DECAL
5	1	3-16678	NON-ROPS DECAL

John Deere 2210
Replacement Parts A-11289
8-14487 ROOF ASSEMBLY

<u>ITEM</u>	<u>QTY</u>	<u>PART NO.</u>	<u>DESCRIPTION</u>
1	1	7-15492	ROOF WELDMENT
2	4	3-14387	NUTSERT ¼-20UNC
3	3	3-10727	GROMMET FOR ¼" HOLE
4 & 5	3	3-16658	HALOGEN LIGHT
6	3	3-12692	HEX HEAD CAP SCREW M6x15x1
7	3	3-10076	LOCK WASHER ¼"
8	3	3-10215	HEX NUT METRIC M6
9	1	6-41756	POLYFOAM
10	2	3-17559	DECAL COZYCAB
11 & 12	1	3-16521	BUBBLE RUBBER 90 DEG
13	2	3-15068	BUBBLE RUBBER 180 DEG
14	2	3-15014	HOLE PLUG 5/16" DIA

John Deere 2210
Replacement Parts A-11289
8-14491 REAR WINDOW ASSEMBLY

<u>ITEM</u>	<u>QTY</u>	<u>PART NO.</u>	<u>DESCRIPTION</u>
1	1	7-15496	REAR WINDOW FRAME WELDMENT
2	1	3-17585	REAR WINDOW ¼" TEMPERED
3	2	3-13931	HEX HEAD CAP SCREW ¼-20UNC x 4.50 LG
4	2	3-10070	NYLOCK HEX NUT ¼-20UNC
5	1	3-10721	HOLE PLUG 3/8"
6	1	3-15234	HOLE PLUG .687"
7	2	3-18022	T-HANDLE SMALL
8	2	3-15576	ROLL PIN
9	1	3-10649	WINDOW RUBBER FOR ¼" GLASS
10	1	3-15952	BUBBLE RUBBER 90 DEG

REV.	DCR NO.	DESCRIPTION	DRAFTSMAN	DATE
			CAD	10-2-03

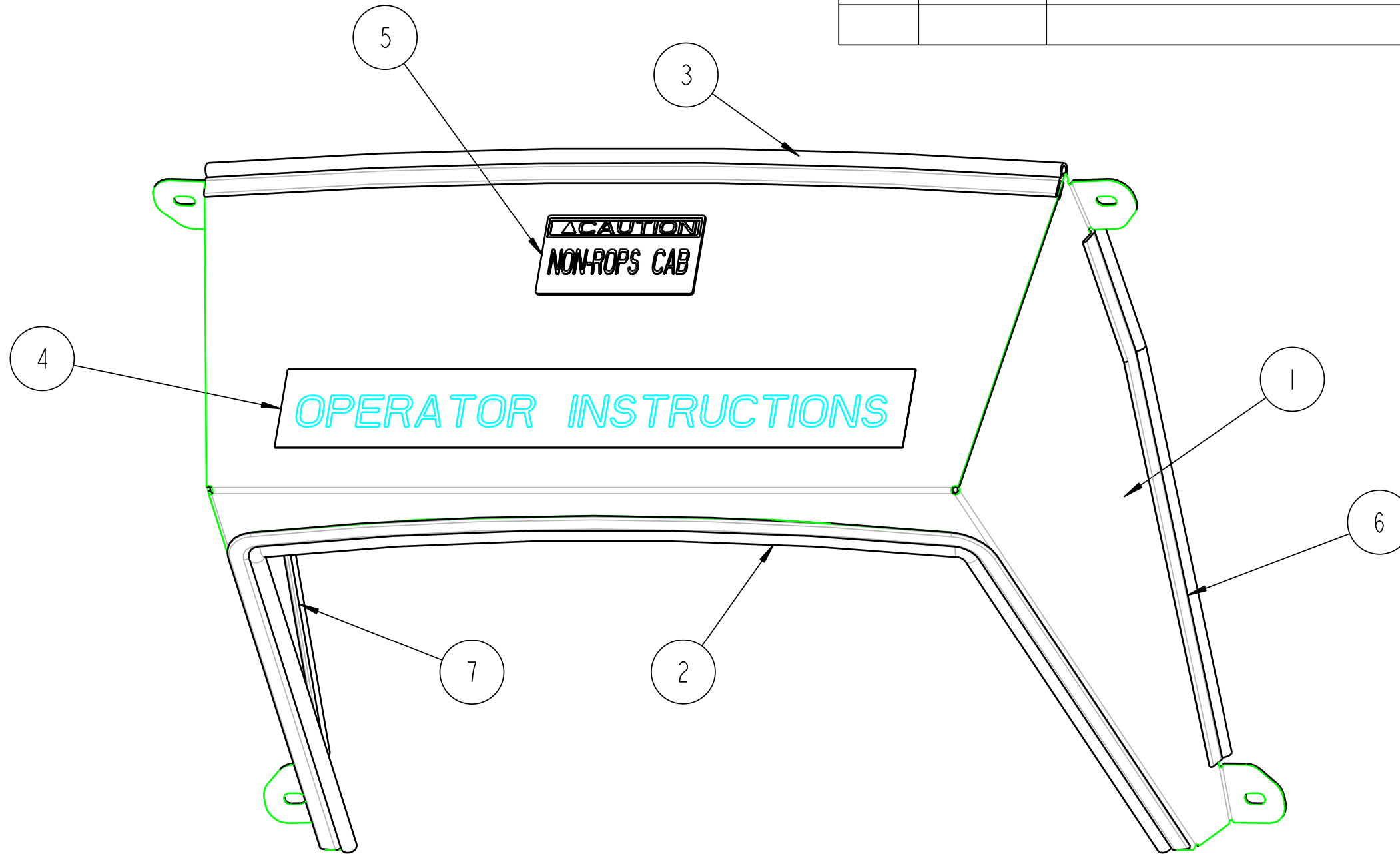

THIS DOCUMENT CONTAINS CONFIDENTIAL INFORMATION AND IS THE PROPERTY OF CUSTOM PRODUCTS OF LITCHFIELD, INC. AND MAY NOT BE COPIED, REPRODUCED OR DISCLOSED IN ANY MANNER WITHOUT EXPRESSED WRITTEN CONSENT FROM CUSTOM PRODUCTS OF LITCHFIELD, INC.

TOLERANCES UNLESS NOTED OTHERWISE	CUSTOMER NAME & MOD NO.:	JD 2210	MATL SPEC:		SEE BOM
	CUSTOM PRODUCTS 1715 SOUTH SIBLEY AVE. LITCHFIELD, MN 55355				
.X ± .09 .XX ± .06 .XXX ± .03 HOLE SIZE +0.015/-0.010 ANGLE ± .5°	TITLE:	HOOD PANEL ASSEMBLY	DRWG SIZE	DRWG NO.	REV LEVEL
			B	8-14731	-
	DRAWN:	CAD	DATE:	7-18-03	

SCALE 0.333

REV.	DCR NO.	DESCRIPTION	DRAFTSMAN	DATE
A	7856	ADDED (2) 3-15014 HOLE PLUGS	CAD	7-1-03

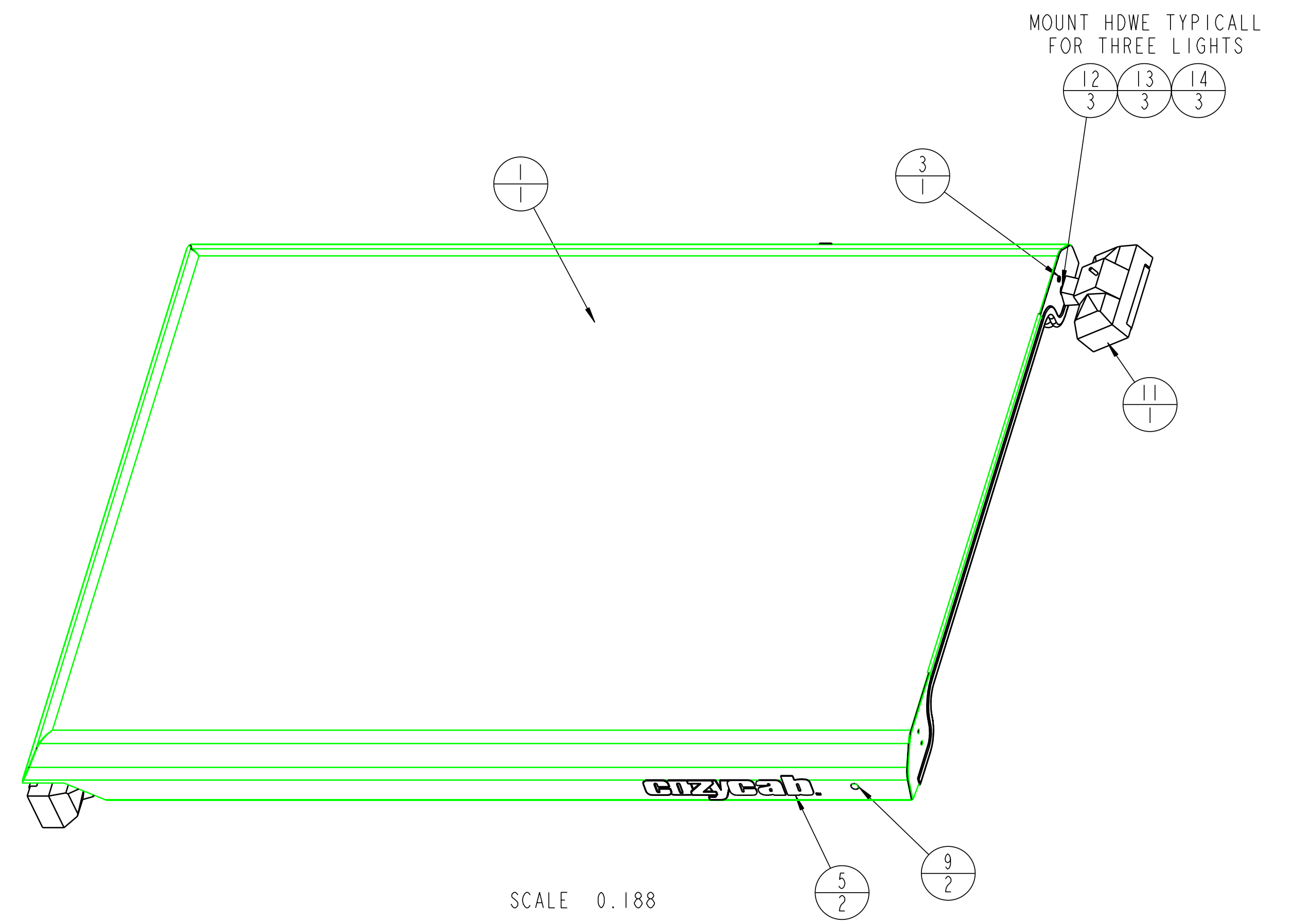
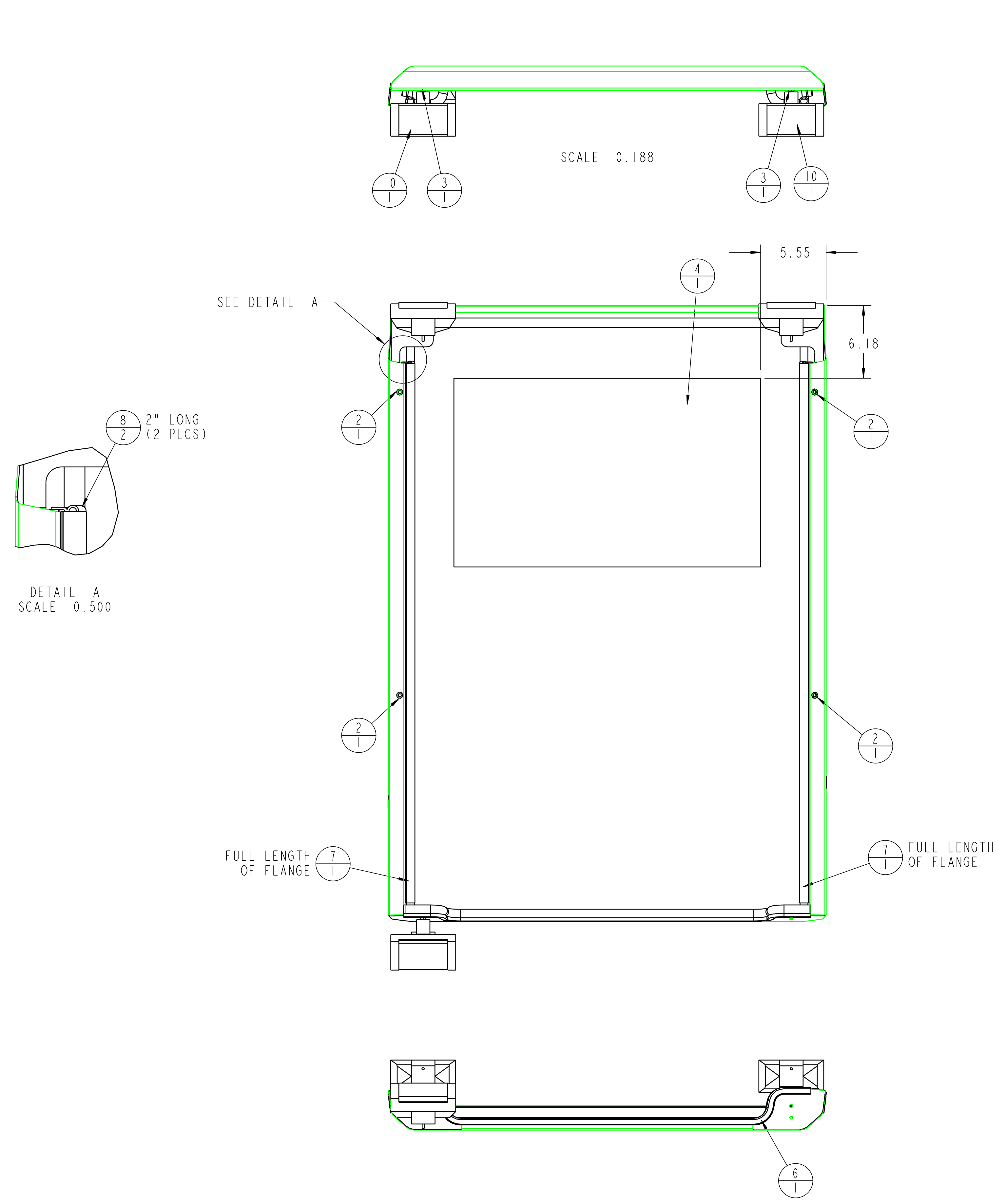

BALLOON INFORMATION
 (ITEM NO.)
 QTY

SHEET 1 of 1

THIS DOCUMENT CONTAINS CONFIDENTIAL INFORMATION AND IS THE PROPERTY OF CUSTOM PRODUCTS OF LITCHFIELD, INC. AND MAY NOT BE COPIED, REPRODUCED OR DISCLOSED IN ANY MANNER WITHOUT EXPRESSED WRITTEN CONSENT FROM CUSTOM PRODUCTS OF LITCHFIELD, INC.

TOLERANCES UNLESS NOTED OTHERWISE	CUSTOMER NAME & MOD NO.: COMMON	MATL SPEC:
	CUSTOM PRODUCTS 1715 SOUTH SIBLEY AVE LITCHFIELD, MN 55355	
X ± .09 XX ± .06 XXX ± .03 HOLE SIZE /05/00 ANGLE ± .5°	TITLE ROOF ASSEMBLY	DRWG SIZE D
	DRWG NO. 8-14487	REV LEVEL A
	DATE 6/25/01	

REV.	DCR NO.	DESCRIPTION	DRAFTSMAN	DATE
A1	-	CHANGE T-HANDLE 3-16831 LONG TO SHORT 3-18022	CAD	8-1-03
A2	-	OMITTED QUICK RELEASE PIN 3-16832	CAD	8-1-03

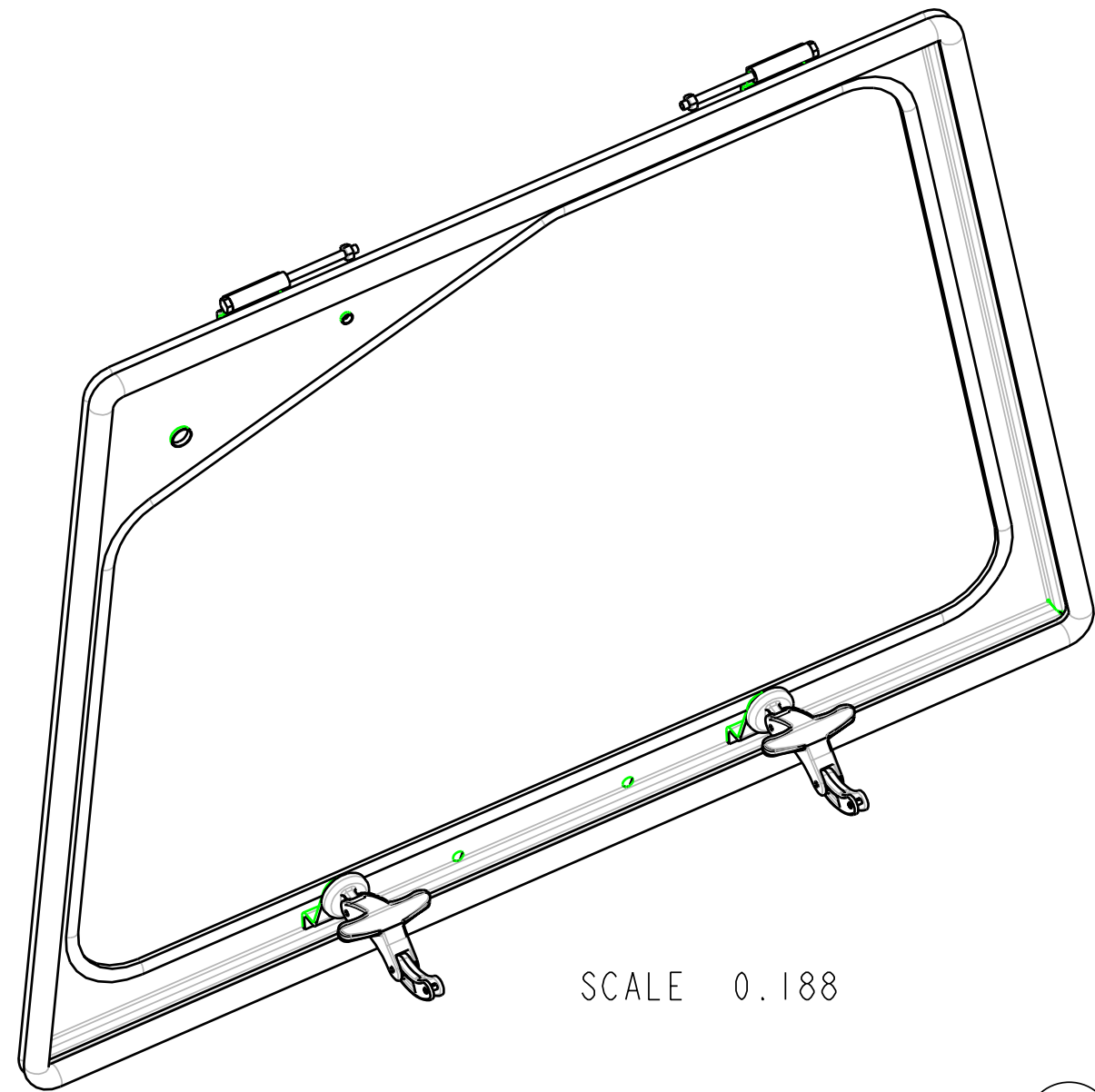

SCALE 0.188

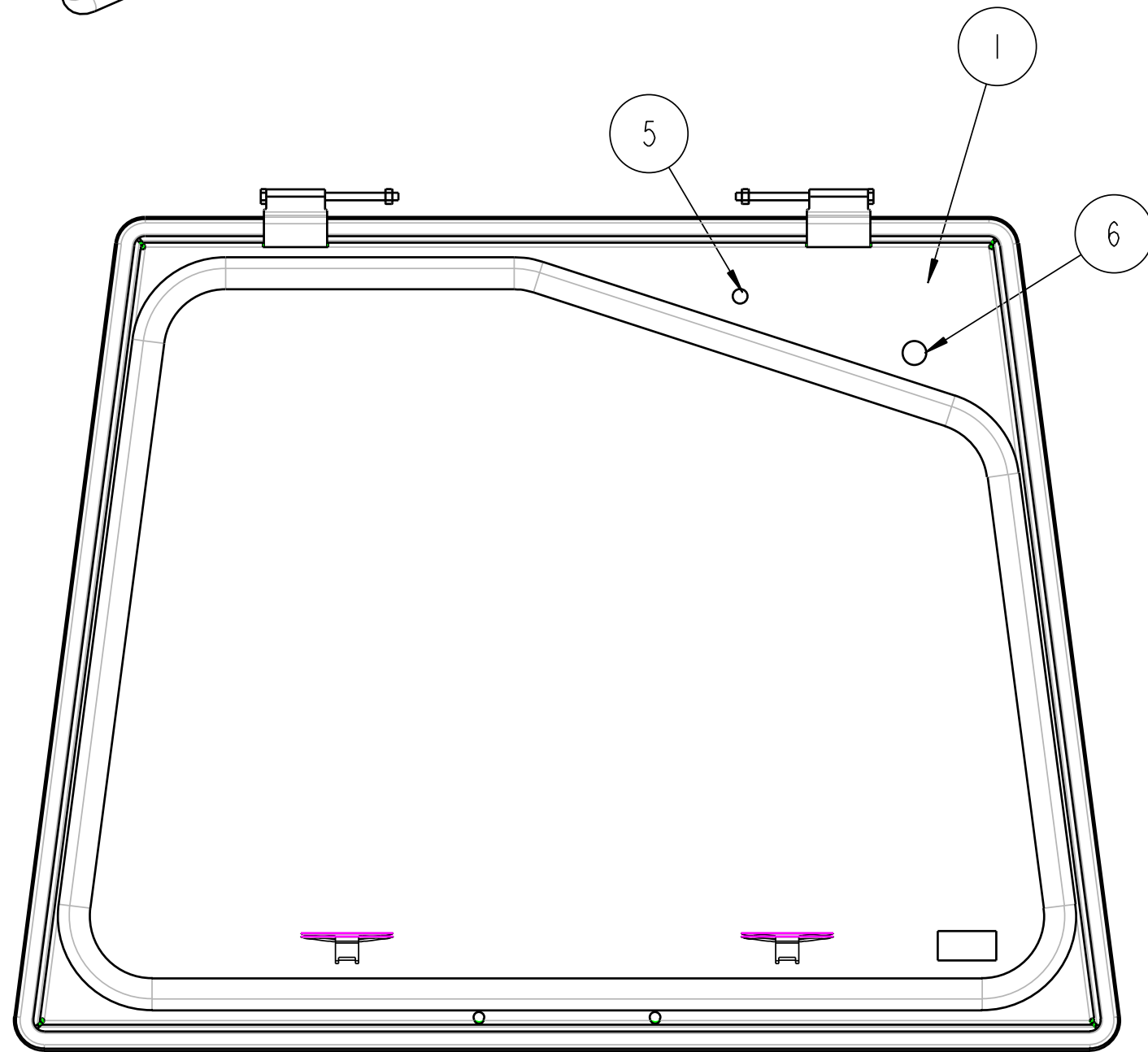

SCALE 0.188

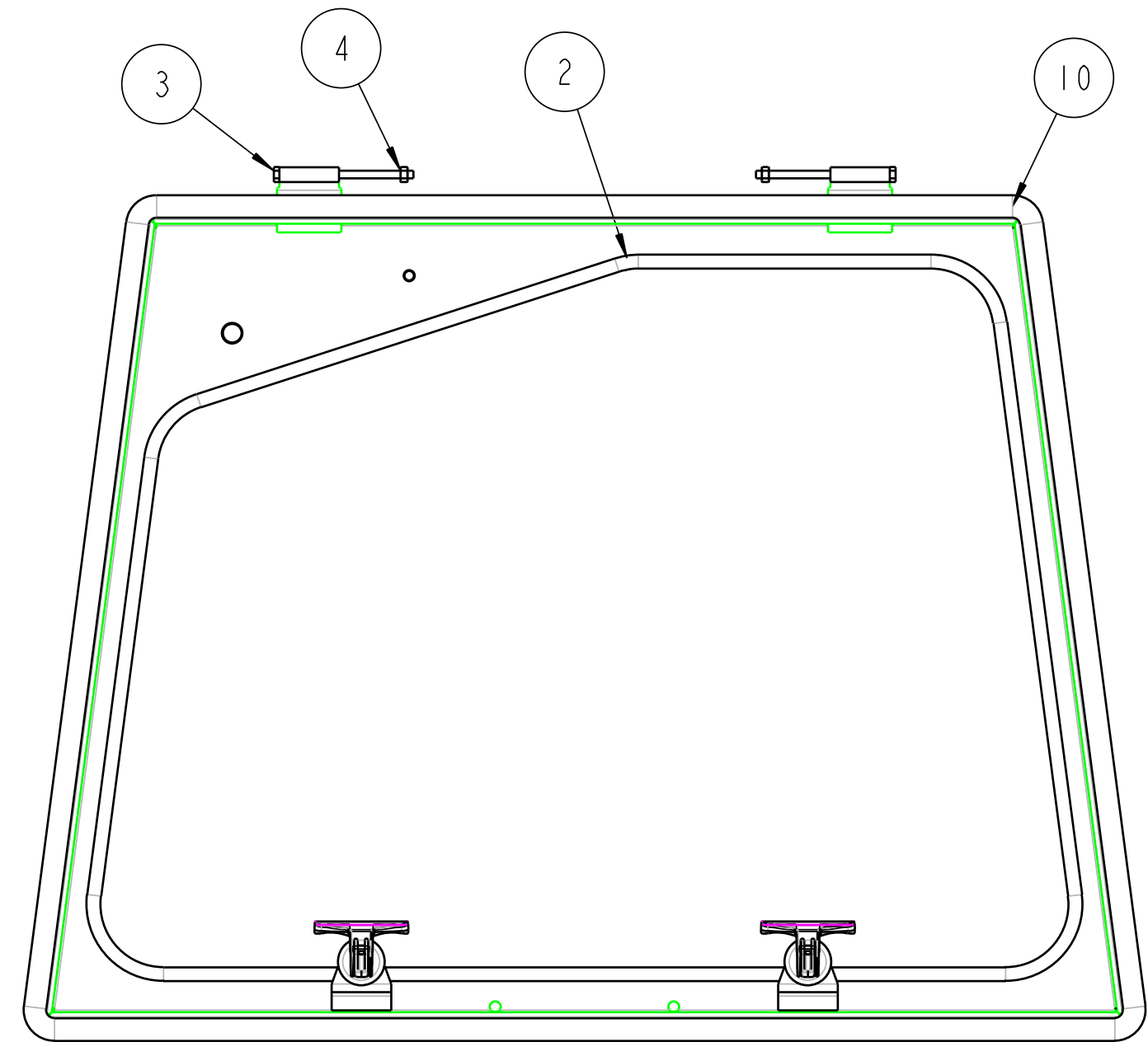
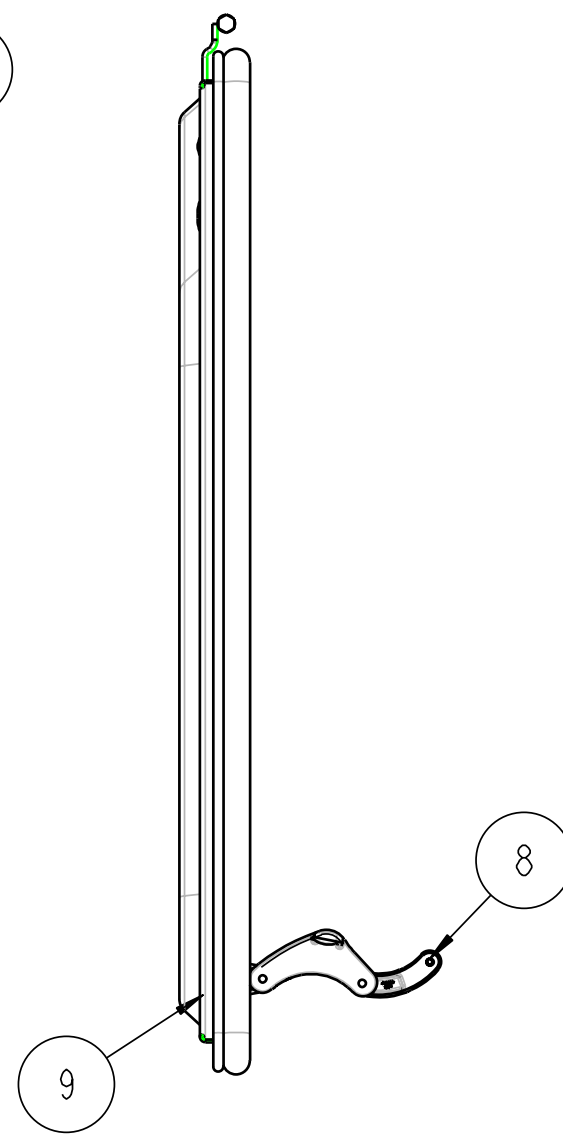

TOLERANCES UNLESS NOTED OTHERWISE X ± .09 XX ± .06 XXX ± .03 HOLE SIZE .015/.010 ANGLE ± 5°	CUSTOMER NAME & MOD NO: COMMON CUSTOM PRODUCTS 1715 SOUTH SIBLEY AVE. LITCHFIELD, MN 55355		MATERIAL SPEC:	
	TITLE ASSEMBLY REAR HINGED WINDOW		DRAWING SIZE C	DRAWING NO. 8-14491
DRAWN: TEO			DATE: 6/25/01	

John Deere 2210
Replacement Parts A-11289
8-14751 HEATER HOOK-UP KIT

<u>ITEM</u>	<u>QTY</u>	<u>PART NO.</u>	<u>DESCRIPTION</u>
1	1	7-11308	RADIATOR LOWER HOSE TEE
2	2	3-10282	HOSE ELBOW FOR 5/8" HOSE
3	8	3-10725	NYLON TIE
4	12 FT	3-11172	HEATER HOSE 5/8"
5	6	3-10858	HOSE CLAMP 5/8"
6	1	3-16265	(REFERENCE) ZIPLOC BAG
7	2	3-12119	HOSE NIPPLE 3/8-18 NPT TO 5/8" HOSE BARB
8	1	3-16823	BUNA N "O-RING"
9	2	3-13442	LARGE HOSE CLAMP
10	1	3-17262	LONG ALUMINUM FITTING

REV.	DCR NO.	DESCRIPTION	DRAFTSMAN	DATE
			CAD	9-25-03

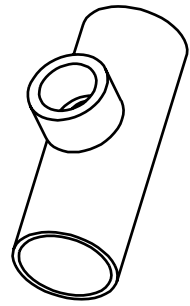

ITEM 1 #7-11308
RADIATOR HOSE TEE
(1 REQ'D)



ITEM 8 #3-16823
BUNA N "O"-RING
(1 REQ'D)

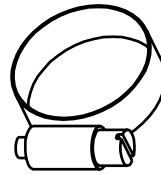

ITEM 9 #3-13442
LARGE HOSE CLAMP
(2 REQ'D)

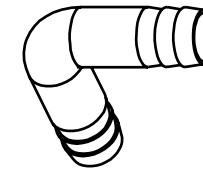

ITEM 2 #3-10282
HOSE ELBOW 5/8"
(2 REQ'D)



ITEM 5 #3-10858
HOSE CLAMP 5/8"
(6) REQ'D

CUSTOMER TO USE PIPE SEALANT
OR TEFLON TAPE AT INSTALLATION
STANDARD PIPE THREAD



ITEM 7 #3-12119
3/8-18 NPT
TO 5/8" ID HOSE NIPPLE
(2) REQ'D

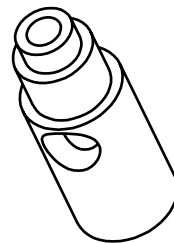

ITEM 10 #3-17262
LONG ALUMINUM ADAPTER
(1 REQ'D)

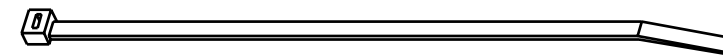

ITEM 3 #3-10725
NYLON WIRE TIE 7.50"
(8 REQ'D)

ITEM 4 (NOT SHOWN) - #3-11172, HOSE, HEATER 5/8" x 12 FEET LG
ITEM 6 (NOT SHOWN) #3-16265 BAG, 10 x 12, ZIPLOCK

THIS DOCUMENT CONTAINS CONFIDENTIAL INFORMATION AND IS THE PROPERTY OF CUSTOM PRODUCTS OF LITCHFIELD, INC. AND MAY NOT BE COPIED, REPRODUCED OR DISCLOSED IN ANY MANNER WITHOUT EXPRESSED WRITTEN CONSENT FROM CUSTOM PRODUCTS OF LITCHFIELD, INC.

TOLERANCES UNLESS NOTED OTHERWISE .X ± .09 .XX ± .06 .XXX ± .03 HOLE SIZE +.015/-0.010 ANGLE ± .5°	CUSTOMER NAME & MOD NO.: JD 2210		MATL SPEC:	
	CUSTOM PRODUCTS 1715 SOUTH SIBLEY AVE. LITCHFIELD, MN 55355			
TITLE: HEATER KIT COMPONENTS		DRWG SIZE: B	DRWG NO.: 8-14751	REV LEVEL: -
		DRAWN: CAD	DATE: 8-5-03	

REV.	DCR NO.	DESCRIPTION	DRAFTSMAN	DATE
A		RELEASED FOR VENDOR PROCESSING	CAD	5-20-03
B		ADDED DETAIL A	CAD	8-5-03

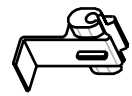

ITEM 16 QTY=1
(SHIPPED LOOSE)

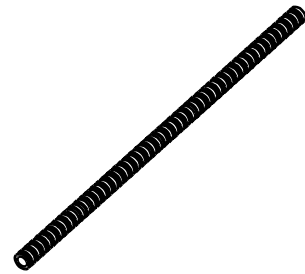

ITEM 17 QTY=1
24" LONG
(SHIPPED LOOSE)



ITEM 18 QTY=1
1/4" INSL BLADE
(SHIPPED LOOSE)

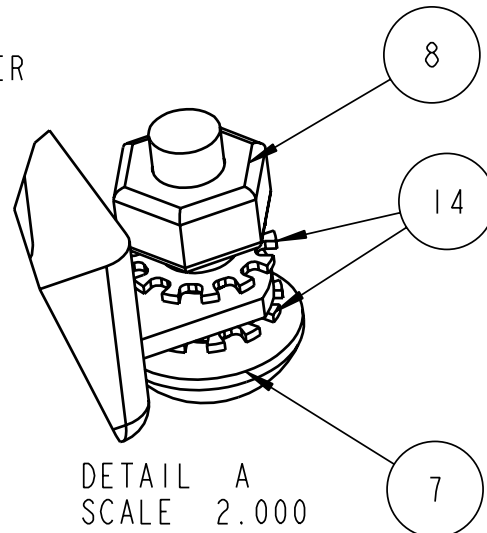
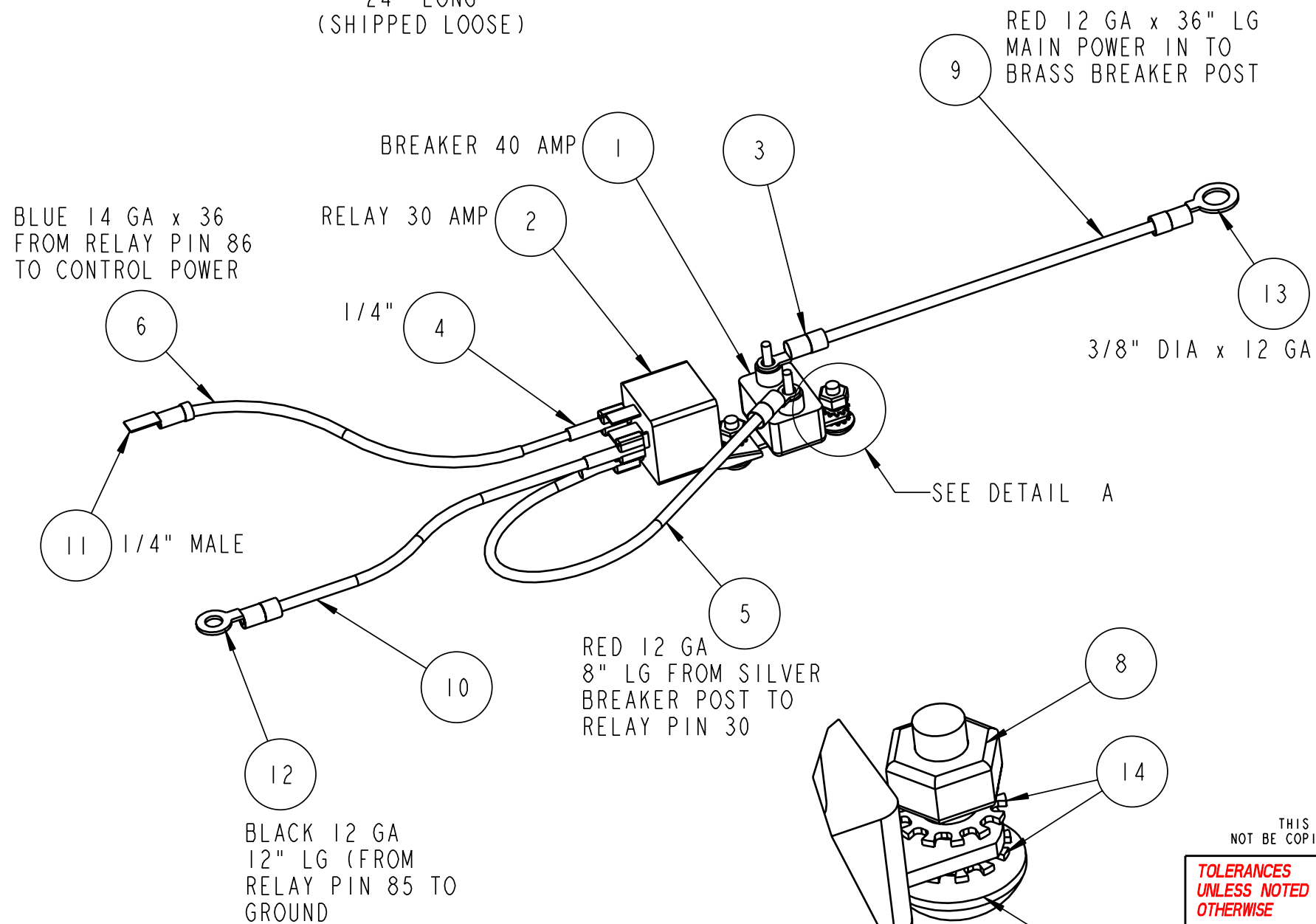

ITEM #	DESCRIPTION	QTY
1	3-11317_BREAKER_40_AMP	1
2	3-12955_RELAY_30_AMP_	1
3	3-10305_TERMINAL EYE 10-12 SMALL	2
4	3-10670_SLIDE FEM CON 14 GA	3
5	3-10351_WIRE_12GA_RED_X_8_	1
6	3-10314_WIRE_14GA_BLUE_X_20_	1
7	3-10104_MSCR_NO10_X_63_THSL	2
8	3-10308_1024_NYLOCK_	2
9	3-10351_WIRE_12GA_RED_X_20_	1
10	3-10340_WIRE_12GA_BLACK_X_12_	1
11	3-11428_TERMINAL_MALE STR	1
12	3-10673_TERMINAL EYE 10-12 GA MED	1
13	3-10674_TERMINAL EYE 10-12 LARGE	1
14	3-13083_WASHER_LOCK_EXT_T	4
15	3-16265_BAG_ZIP_10_X_12	SEE BOM
16	3-10982_SPLICE CONNECTOR 3-WAY BLUE	1
17	3-10704_PLASTIC WIRE DUCT .350 x 24" LG	1
18	3-14553_BLADE CON 1/4" INSL 14-16 GA	1
19	3-16265_PLASTIC BAG ZIP 10x12	1

BOM NOTES:

ITEM 19 - (NOT SHOWN) ALL PARTS TO BE PLACED IN THIS BAG

THIS DOCUMENT CONTAINS CONFIDENTIAL INFORMATION AND IS THE PROPERTY OF CUSTOM PRODUCTS OF LITCHFIELD, INC. AND MAY NOT BE COPIED, REPRODUCED OR DISCLOSED IN ANY MATTER WITHOUT EXPRESSED WRITTEN CONSENT FROM CUSTOM PRODUCTS OF LITCHFIELD, INC.

CUSTOMER NOTE:

- 12 GA RED WIRE -FROM RELAY PIN 87 ROUTES TO FUSE BLOCK TERMINAL STUD
- 3-WAY SPLICE (ITEM 16) MAY BE USED INSTEAD OF BLADE CONNECTOR (ITEM 11)

TOLERANCES
UNLESS NOTED
OTHERWISE

.X ± .09
.XX ± .06
.XXX ± .03
HOLE SIZE
1:015/-010
ANGLE ± .5°

CUSTOMER NAME & MOD NO.: UNIVERSAL RELAY-BREAKER HARNESS		MATL SPEC:	
CUSTOM PRODUCTS 1715 SOUTH SIBLEY AVE. LITCHFIELD, MN 55355			
TITLE: UNIVERSAL WIRE RELAY BREAKER HARNESS	DRWG SIZE: B	DRWG NO.: 3-17803	REV LEVEL: B
DRAWN: CAD	DATE: 4-5-02		

REV	DCR/ECO NO.	DESCRIPTION	DRAFTSMAN	DATE
A		UPDATED TO PRO E	CAD	8-26-02

