

COZYcab™

JOHN DEERE 4500, 4510, 4600, 4610, 4700 and 4710 CAB MOUNTING INSTRUCTIONS



Fits with 460 loader and over 2 post
Non-Folding and Folding ROPS Models

A-11202

Manufactured by:

CUSTOM PRODUCTS
OF LITCHFIELD, INC.

BOX 70 • LITCHFIELD, MINNESOTA 55355-0070
(320) 693-3221 Fax: (320) 693-7252
www.800cabline.com

SAFETY INSTRUCTIONS

Read operator's manual. Be thoroughly familiar with the controls, capabilities, and proper use of the equipment.

NEVER ALLOW ANY RIDERS.

IMPORTANT: This cab must only be used on tractors outfitted with a NON-FOLDING OR FOLDING ROPS.

DO NOT remove the top half of a folding ROPS to accommodate this cab.

Thoroughly inspect cab mounting periodically.

Stay alert for hidden hazards and traffic.

Avoid sudden starts, excessive speeds, and sudden stops when operating on hillside, rough ground and most off-the-road operations.

Use extreme care when working close to fences, ditches, or on hillsides.

Wait for tractor to STOP before dismounting.

Check clearance carefully before driving under any objects.

Avoid operating sideways on a steep slope whenever possible.

ALWAYS buckle safety belt while operating tractor.

Never exceed factory recommended specifications.

DO NOT weld, cut drill or modify ROPS in any manner unless instructed by manufacturer.

John Deere 4500, 4510, 4600, 4610, 4700 and 4710 MOUNTING INSTRUCTIONS

Preparation of tractor

- 1) Remove grab handles from fenders.
- 2) Open mounting kit box and layout parts.
- 3) Remove warning lights from roll bar. Attach warning lights to dual light mount brackets 7-15661 & 7-15662, using hardware provided: (4) 8mm x 25mm cap screws & (4) 5/16" lock-washers.
- 4) Remove side engine panels.
- 5) Attach rear mount using (4) 1/2"x 2" bolts, (8) 1/2" flat washers, and (4) 1/2" nylock nuts. Set the rear mount bracket on top of the tractor's rear mount location (Figures 1 & 2).

NOTE: If the tractor is equipped with a mid-mount mower, use the bracket on the bottom of the rear mount assembly to attach the outer side of the mower pivot bracket, as shown in Figure 2.



Figure 1

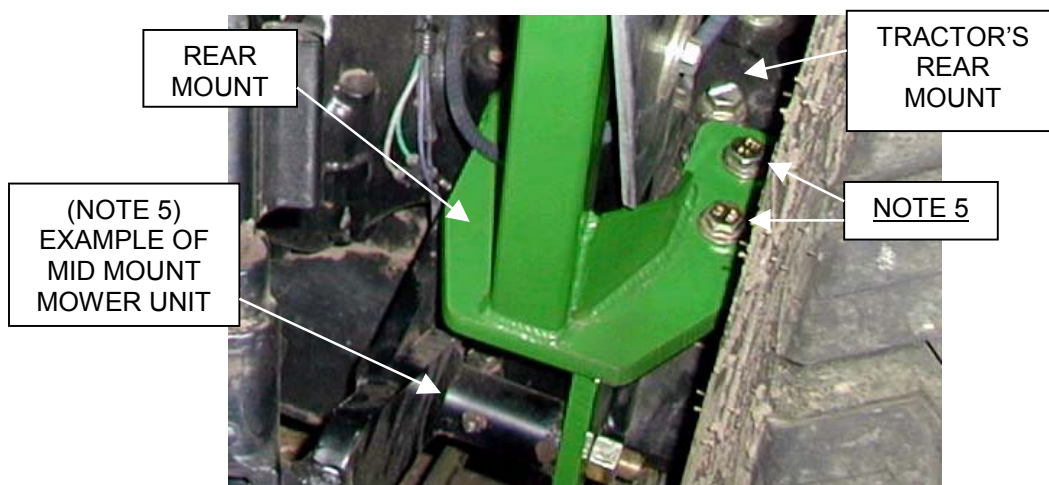

Figure 2

John Deere 4500, 4510, 4600, 4610, 4700 and 4710 MOUNTING INSTRUCTIONS (Continued)

- 6) Attach front mounts #6-40872 (RH) and #6-40888 (LH) to JD loader mounts using (4) ½" u-bolts #3-17489, (8) small flat washers #3-12466, (2) spacer washers #6-40606 and (8) ½" nylock nuts #3-10379.
- 7) Leave loose until rubber isolators and bolts are installed (See Figure 3). Note that there are distinct left and right front mounts.

NOTE: If the tractor is not equipped with loader mount brackets, they must be purchased from JOHN DEERE.

- 7a) Install (2) rubber isolator bushings #3-16635 in front mounts with (2) spacer washers, #6-40606 on the top side of each front mount plate. (See Figure 3).
- 7b) Install rubber isolators 3-16635 into rear mount 2-15370.

NOTE: Rubber isolators with pipe bushing should be inserted from top side of mount.

- 8) Remove the "Slow Moving Vehicle" sign from the rear of the seat. Attach the lower window rubber. If no holes are present, drill two 5/16" diameter holes that are 6" apart (centered horizontally on window).
- 9) Attach "Slow Moving Vehicle" sign into holes using ¼" hardware provided and stainless steel standoffs.
- 10) Tilt seat forward against steering wheel.

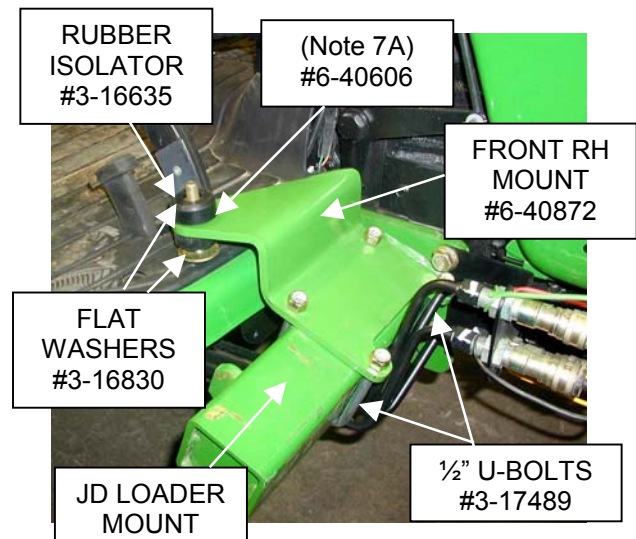

Figure 3



Figure 4

John Deere 4500, 4510, 4600, 4610, 4700 and 4710 MOUNTING INSTRUCTIONS (Continued)

Installation of cab

- 12) Remove cab from shipping stand.

FOLDING ROPS VS. NON-FOLDING ROPS MODELS:

- 13) Note: Tractors equipped with the **taller Folding ROPS** need clearance to the roof shell area from inside the cab. Remove the ROPS cover panel 8-14617. The poly-fabric will have a factory pre-cut slot to allow the **Folding ROPS** to fit into the roof shell area when cab is lowered on to the tractor. Refer to Figure 18.
- 14) Note: Models with the **shorter Non-Folding ROPS** do not need panel 8-14617 removed. The shorter ROPS clears and fits under the cover panel.
- 15) Lower cab over roll bar until cab contacts front and rear isolator bushings. (Guide Folding ROPS into the roof shell area). Secure cab to mounts using (4) $\frac{1}{2}$ " x $3\frac{1}{4}$ " bolts, (8) large flat washers, and (4) lock-nuts. See Figures 3, 4 and 15.
- 16) If cover panel 8-14617 was removed, re-install and secure with (6) 10-24unc screws. See Figure 18.

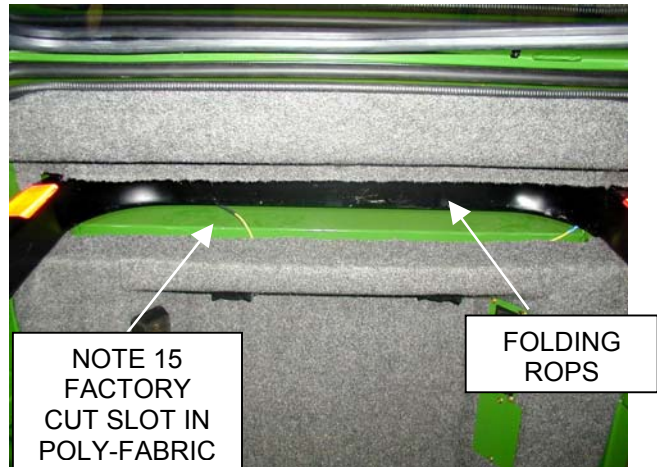

Figure 15
(FOLDING ROPS MODEL SHOWN)

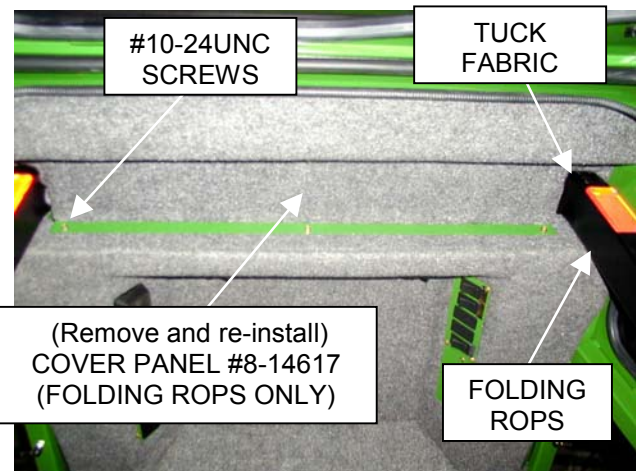

Figure 18
(FOLDING ROPS MODEL SHOWN)

**John Deere 4500, 4510, 4600, 4610, 4700 & 4710
CAB MOUNTING INSTRUCTIONS (Continued)**

17) Loosen lifting ear bolts, tilt lifting ears down, and tighten bolts.

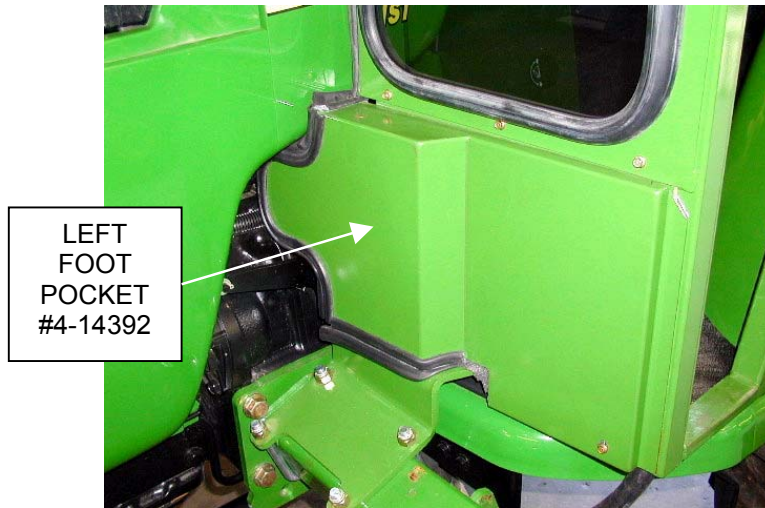

Figure 5

18) Attach front left and right foot pockets using (8) #10-24 x 5/8" bolts (See Figure 5).

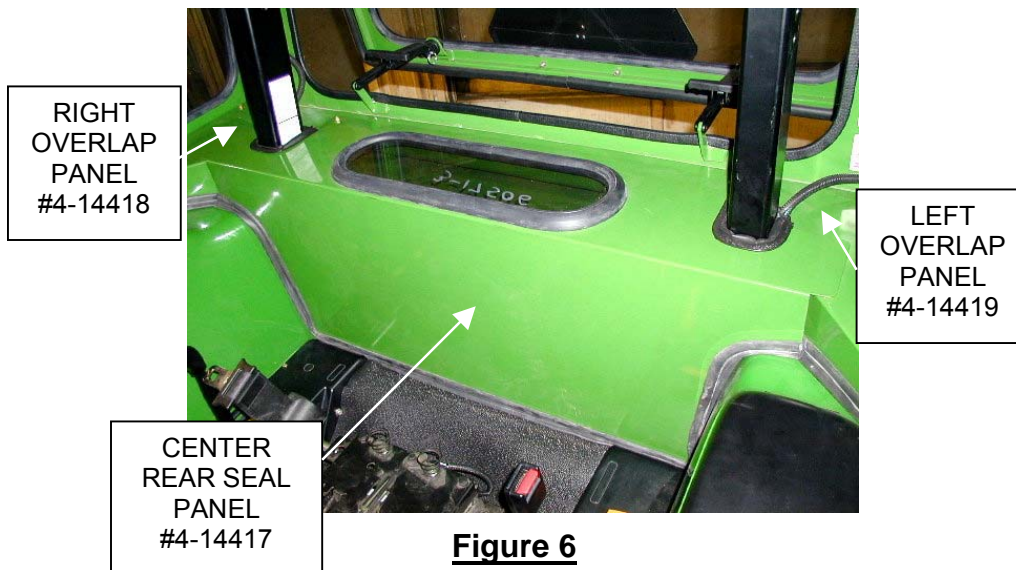

Figure 6

19) Install rear overlaps, left #4-14419, right #4-14418 panel and rear center seal panel #4-14417. Secure using (6) #10-24 x 5/8" bolts. See Figure 6.

**John Deere 4500, 4510, 4600, 4610, 4700 & 4710
CAB MOUNTING INSTRUCTIONS (Continued)**

Electrical Hookup

- 20) Locate the wire relay breaker harness #3-17803 that comes with the mount kit. Review Figure 6 for proper location and mounting.
- 21) If holes are not present, drill two 1/4" holes. Use the (2) #10 x 5/8" machine screws, washers and nuts, from the wire relay breaker harness to attach these components.

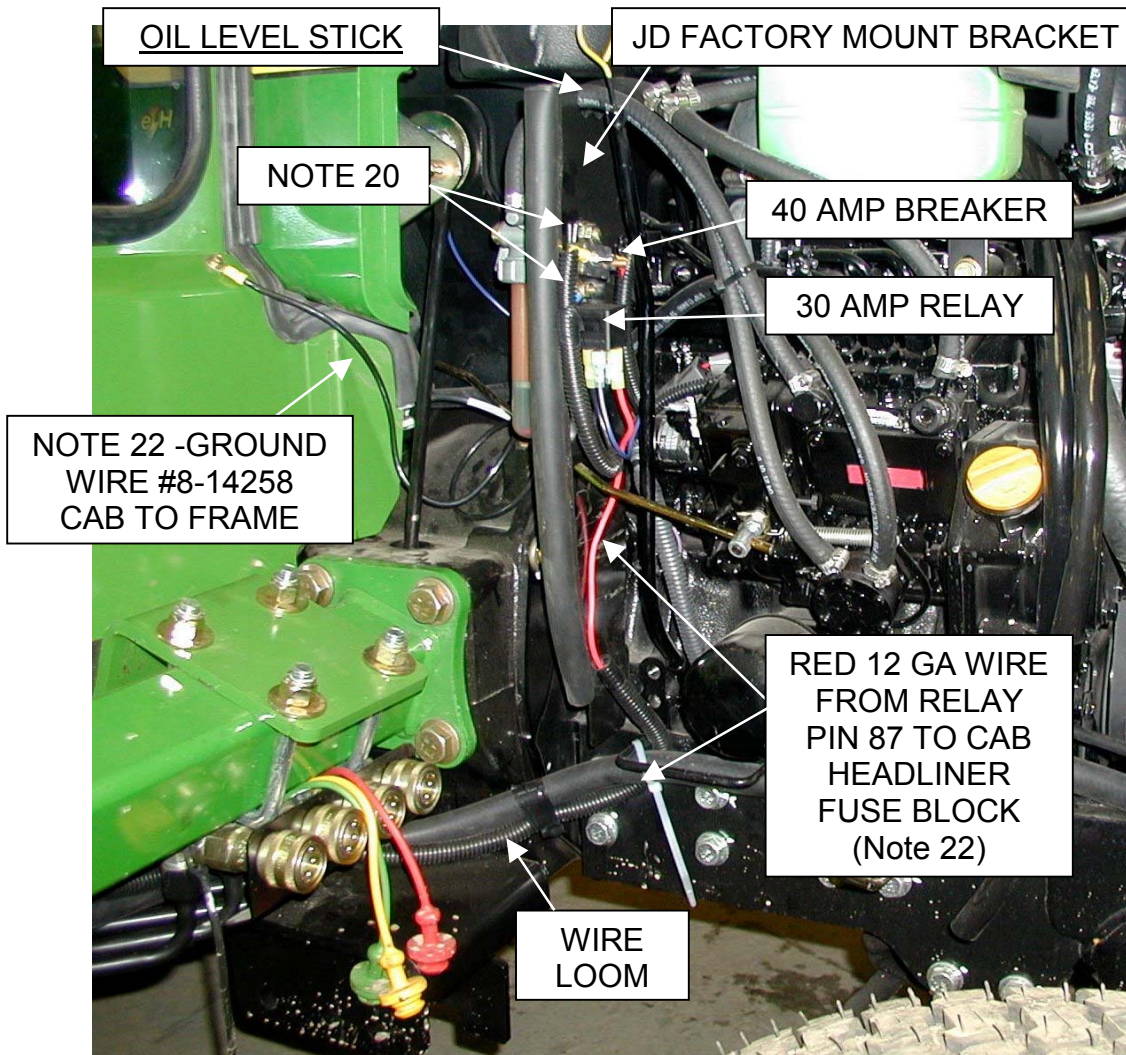

FIGURE 6

- 22) Refer to drawings #3-17803 and #8-14376 for additional electrical detail.
- 23) The main power wire to the headliner fuse block should be pre-routed from the factory, down the right side of the cab frame.
- 24) Connect the Cab to Frame Grounding Wire Assembly #8-14258.

John Deere 4500, 4510, 4600, 4610, 4700 and 4710 MOUNTING INSTRUCTIONS (Continued)

Heater Hook-Up

- 25) Drain coolant from radiator and engine block.
- 26) Use thread sealant on all pipe threads.
- 27) Locate the top pipe plug on the water pump near the engine's thermostat. Remove the plug.
- 28) On models; (See Figure 7).
 - *4510, 4610 and 4710**
 - Install (1) #3-17756, 3/8-19 BSPT to 5/8" hose nipple.
 - *4500, 4600 and 4700**
 - Install (1) #3-12119, 3/8-18 NPT to 5/8" hose nipple.
- 28) Locate where the lower radiator hose connects to the water pump. Just above this connection, locate the pipe plug port and remove the plug.
- 29) On models; (See Figure 7).
 - *4510, 4610 and 4710**
 - Install (1) #3-17757, 3/8-19 BSPT to 5/8" hose nipple.
 - *4500, 4600 and 4700**
 - Install (1) #3-12119, 3/8-18 NPT to 5/8" hose nipple.
- 30) Locate the heater hose, (2) 90-degree plastic elbows and (6) 5/8" hose clamps that come with the kit.
- 31) Install (1) elbow #3-10282, measure and cut 5/8" heater hose from right side of cab to the hot-pressure nipple on the top of the water pump, just installed. See Figure 8.
- 32) Install (1) elbow #3-10282, measure and cut heater hose from left side of cab to the lower radiator return nipple, just installed. See Figure 9.
- 33) Tighten all connections using 5/8" hose clamps supplied with the kit.
- 34) To check the "H" Valve and hose routing, remove the roof to inspect the cab's headliner heater area. See Figure 10.

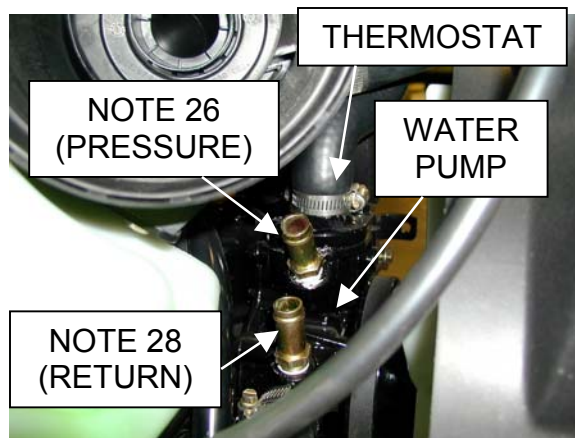

Figure 7

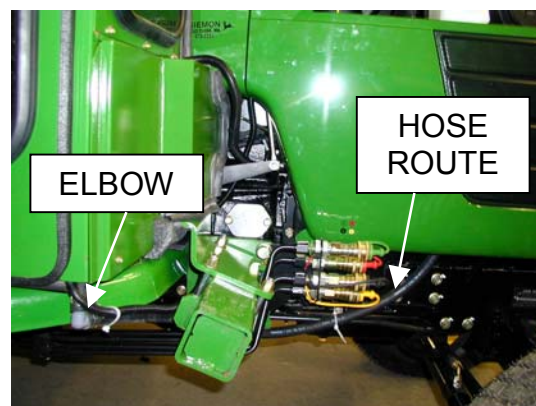

Figure 8

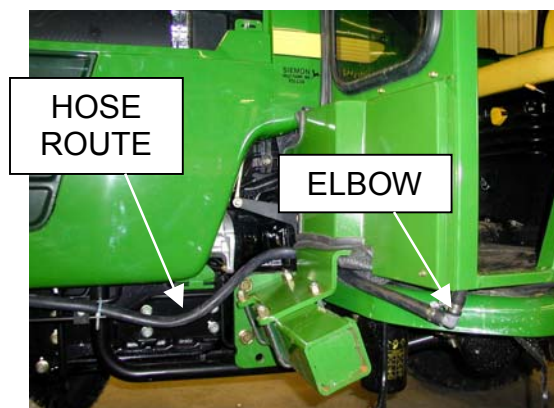

Figure 9

**John Deere 4500, 4510, 4600, 4610, 4700 & 4710
CAB MOUNTING INSTRUCTIONS (Continued)**

- 35) Verify hose routing from water pump nearest the thermostat to the top nipple of the "H" valve. See Figure 10.
- 36) Also, check that the return hose from the lower "H" valve nipple is routed to the lower radiator hose port return nipple.

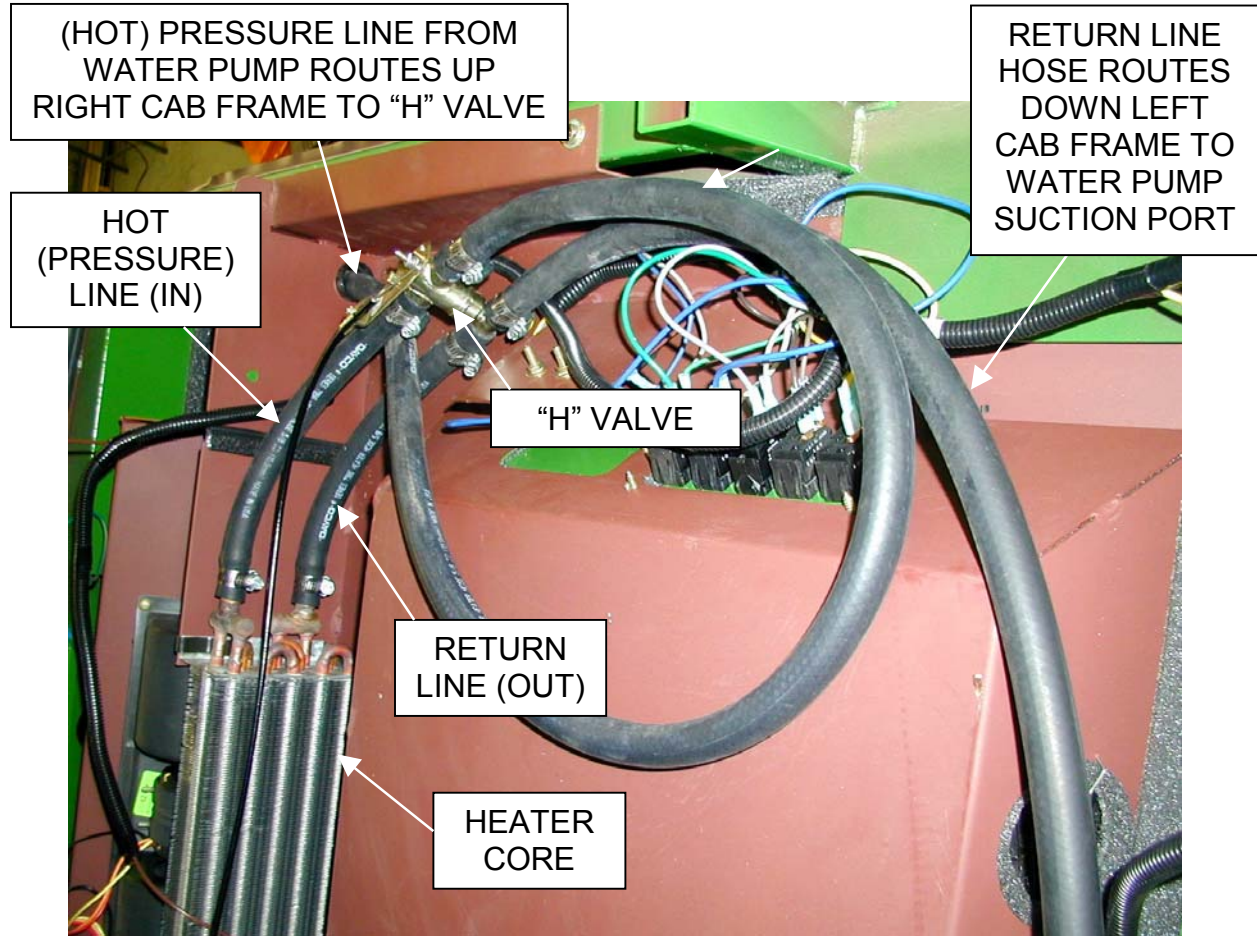

Figure 10

- 37) Refill radiator.
- 38) Reconnect battery and start engine. Run at fast idle to purge air from system and check for any leaks. Cycle the heat/pull lever from inside the cab, on and off several times while engine is running. Check coolant level after heater core and hoses are filled.
- 39) Some cab owners may chose to remove the cab for the summer and re-install in the fall. Keep and store the removed port plugs for re-use.

MOUNTING INSTRUCTIONS ADDENDUM

John Deere 4500, 4510, 4600, 4610, 4700 and 4710

A. REAR WARNING LIGHTS MOUNTING (INSTRUCTION)

The mount kit comes with 2 dual or single light mounting brackets. Part numbers 7-15661 AND 7-15662.

Use these brackets when remounting lights onto cab. Use (4) M8 x 25 mm cap screws (Part Number 3-10123), 5/16" lock washers to secure bracket. Install light bracket to cab with 1/4-20unc x 3/4" screws (Part number 3-10219), lock-washers and flat washers to secure bracket to cab.

B. STEP EXTENSION MOUNTING (INSTRUCTION)

Since the cab is extended beyond the tractor's factory step, the mount kit comes with a step extension part number 7-15446. See cover of manual.

The new step extension installs onto the tractor's factory step. Use back up plate part number 6-41222 under the factory step and secure with (3) Qty 3-10046 (1/2-13UNC x 1-1/2" long) bolts, (3) 1/2-13UNC Nylock nuts and (2) 1/2" flat washers for the slot mount hole.

C. ROOF OPTIONS, 4500; "00" and "10" Series Models

As of November 2002, cabs will be equipped with a standard folding ROPS roof. The roof will have a domed shell in the rear part of the roof to allow clearance of the taller folding ROPS from the interior of the cab. The same folding ROPS roof, fits both "00" and "10" Series, ROPS and NON-ROPS Models.

D. Exhaust Extension Kit

For applications that require a high exhaust system, over the head of the operator, a vertical exhaust kit is available through your John Deere dealer. As of this document's date, the vertical exhaust kit LVB 25013 may be used on models 4500, 4510, 4600, 4610, 4700 and 4710 series. Verify correct kit number with your John Dear dealer.

**John Deere 4500, 4510, 4600, 4610, 4700 & 4710
A-11202 Replacement Parts**

ASSEMBLY DRAWINGS

CP PART

DESCRIPTION

8-14383	REPLACEMENT PARTS, ASSEMBLY, CAB
8-14384	REPLACEMENT PARTS, ASSEMBLY, RIGHT DOOR
8-14385	REPLACEMENT PARTS, ASSEMBLY, LEFT DOOR
8-14386	REPLACEMENT PARTS, ASSEMBLY, MOUNT KIT
8-14387	REPLACEMENT PARTS, ASSEMBLY, HEADLINER
8-14400	REPLACEMENT PARTS, ASSEMBLY, REAR HINGED WINDOW
8-14417	REPLACEMENT PARTS, ASSEMBLY, CENTER REAR SEAL
8-14593	HEATER HOOK UP KIT
4-14376	WIRING SCHEMATIC
3-17803	UNIVERSAL WIRE RELAY BREAKER HARNESS

ROOF PARTS REFERENCE

N/A	NON-FOLDING ROPS ROOFS
8-14388	FOLDING ROPS ROOFS

**John Deere 4500, 4510, 4600, 4610, 4700 & 4710
A-11202 Replacement Parts**

MAIN CAB ASSEMBLY DRAWING 8-14383

<u>DRAWING</u> <u>ITEM NO.</u>	<u>CUSTOM PROD.</u> <u>PART NO.</u>	<u>ITEM</u> <u>DESCRIPTION</u>
1	7-15367	WELDMENT, MAIN CAB
2	8-14384	ASSEMBLY, RIGHT DOOR
3	3-15407	STRIKER STUD WWASHER, 7/16-14 NC X 1-1/4" LONG
4	3-10166	WASHER, 7/16" FLAT
5	3-10472	HEX NUT, NYLOCK, 7/16-14 NC
6	3-10077	WASHER, 5/16" FLAT
7	3-11821	BALL STUD, GAS SPRING, 10MM
8	3-13024	GAS SPRING, 20 PSI, 6" STROKE, 10MM ENDS
9	3-11822	CLIP, GAS SPRING, 10MM
10	8-14385	ASSEMBLY, LEFT DOOR
11	8-14386	ASSEMBLY, MOUNT KIT
12	3-16600	NUT-SERT, #10-24 NC
14	3-14387	NUT-SERT, 1/4-20 NC
15	3-10076	WASHER, 1/4" LOCK
16	3-10220	HEX-HEAD BOLT, 1/4-20 NC X 1" LONG, GRD 5
17	8-14388	ASSEMBLY, ROOF FOLDING ROPS (STANDARD)
18	6-20618	LIFTING EAR
19	3-10087	WASHER, 1/2" FLAT
20	3-10079	WASHER, 1/2" LOCK
21	3-10129	HEX-HEAD BOLT, 1/2-13 NC X 1" LONG, GRD 5
22-23	3-11928	WEATHERSTRIP, V-SEAL, 7/8" WIDE, PSA BACK
24	3-15279	RUBBER, D-SEAL, 9/16" HIGH X 3/4" WIDE, PSA BACK
25	3-15068	SEAL RUBBER, 3/8" OD BUBBLE, UP TO 1/8" MATERIAL
26	8-14400	ASSEMBLY, REAR HINGED WINDOW
27	3-10778	TRIM, PINCHWELD, LARGE
28-29	3-17465	SEAL FOAM, 1-1/2" SQUARE EPDM, 45" LONG
30	3-15279	RUBBER, D-SEAL, 9/16" HIGH X 3/4" WIDE, PSA BACK
31	3-10610	SEAL RUBBER, CLIP-ON BUBBLE, 180 DEGREE
32-35	3-10649	WINDOW RUBBER, 1/8" OFFSET, FOR 1/4" THICK GLASS
36	3-17468	GLASS, SIDE REAR (7/32" THICK)
37	3-17469	GLASS, FRONT LOWER (7/32" THICK)
38	3-17470	GLASS, WINDSHIELD (1/8" THICK)
39	3-15944	AIR FILTER, 2-3/16" X 3" X 20-7/8"
40	6-40507	COVER, AIR FILTER
41	3-15573	KNOB, BLACK PLASTIC, 1-3/4" DIA
42	3-11264	POLYFOAM, 1/8" X 5/8", PSA BACK
43	3-10727	GROMMET, SNAP BUSHING, 1/4" DIA MOUNTING HOLE
44	3-15524	FLOOD LIGHT, RECTANGULAR, 12 V
45	3-11099	WIPER MOTOR, 12V, 1" SHAFT, SINGLE SPEED
46	3-10083	WASHER, 3/16" FLAT
47	3-10135	SCREW, #10-24 NC X 1" LONG, TRUSS HEAD, SLOTTED
48	3-10308	HEX NUT, NYLOCK, #10-24
49	3-15776	WIPER ARM, PANTOGRAPHIC, 16" LONG, FOR WWF'S
50	3-15763	WIPER BLADE, 16" FLEX, WIDE

**John Deere 4500, 4510, 4600, 4610, 4700 & 4710
A-11202 Replacement Parts**

MAIN CAB ASSEMBLY DRAWING 8-14383 (Continued)

DRAWING ITEM NO.	CUSTOM PROD. PART NO.	ITEM DESCRIPTION
51	3-16678	SAFETY DECAL, "CAUTION NOT A ROPS"
52	6-41115	INSULATION, 1/4" HEATHER CHARCOAL, ROPS POCKET
53	3-10219	HEX HEAD BOLT, 1/4-20UNC x 3/4" LG
54	3-10729	GROMMET, SNAP BUSHING, 3/8" DIA x .44" MNTG HOLE
55	3-10123	HEX HEAD BOLT, M8 x 25 METRIC
56	REF	FOLDING ROPS (REFERENCE ONLY)
57	3-17929	U-NUT, 10-24UNC CLIP
58	8-14671	ROPS COVER PANEL
59	3-14927	SCREW, FLANGE TYPE NUMBER 10-24UNC x 5/8" LG

REV.	DCR NO.	DESCRIPTION	DRAFTSMAN	DATE

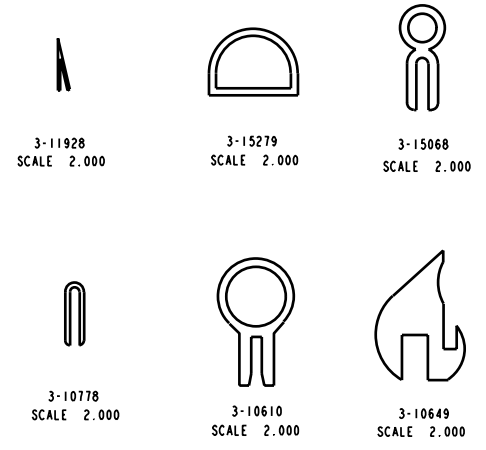
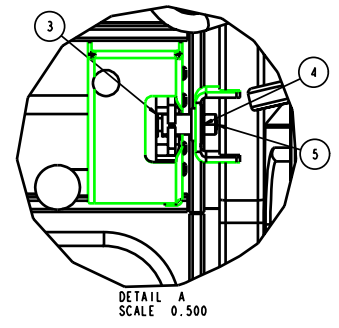
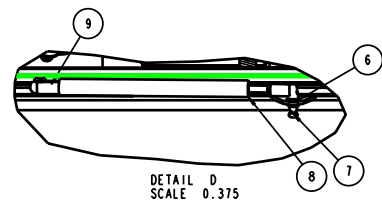
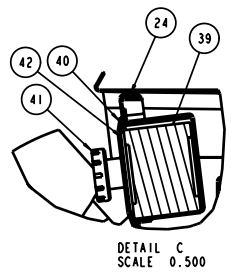
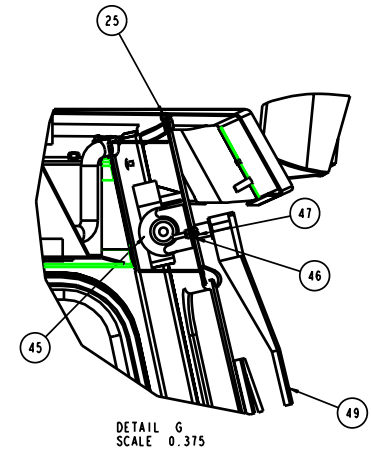
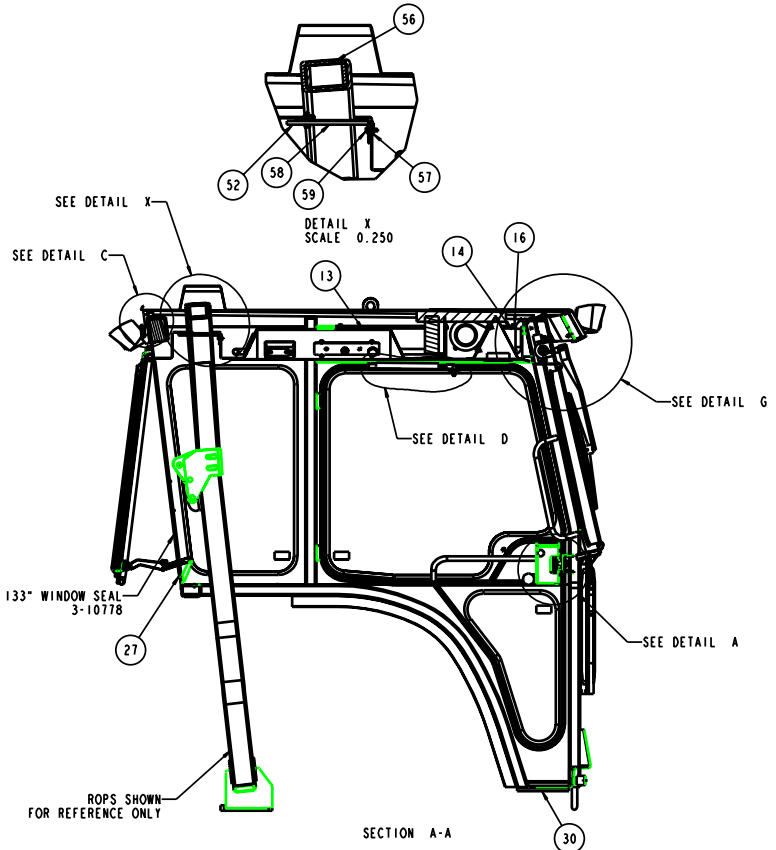
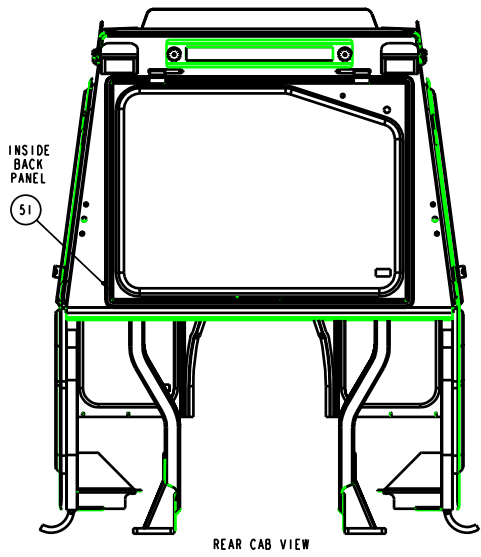

TOLERANCES UNLESS NOTED OTHERWISE		CUSTOMER NAME & MFG NO. JD 4500-4710		FILE NO.
3 ± .00 3/16 ± .00 3/32 ± .00 HOLE SIZE H/8 ± .005		CUSTOM PRODUCTS 1716 SOUTH GABLEY AVE LITOTFIELD, MN 55355		REV. LEVEL
REPLACEMENT PARTS MAIN CAB ASSEMBLY		QTY REQ. D	QTY ON HAND 8-14383	REV. LEVEL 2 of 2
DWG. CAD		REV.	4-23-02	

REV.	DCR NO.	DESCRIPTION	DRAFTSMAN	DATE
------	---------	-------------	-----------	------

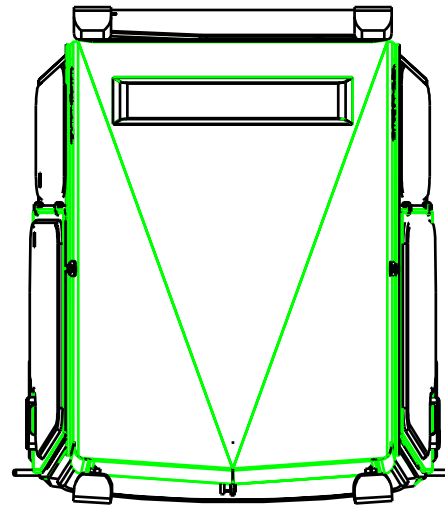

SIDE WEATHERSTRIP 52.5"

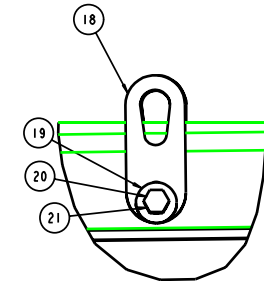

DETAIL H
SCALE 0.500

REAR WEATHERSTRIP 47"

FRONT WEATHERSTRIP 42"

SEE DETAIL H

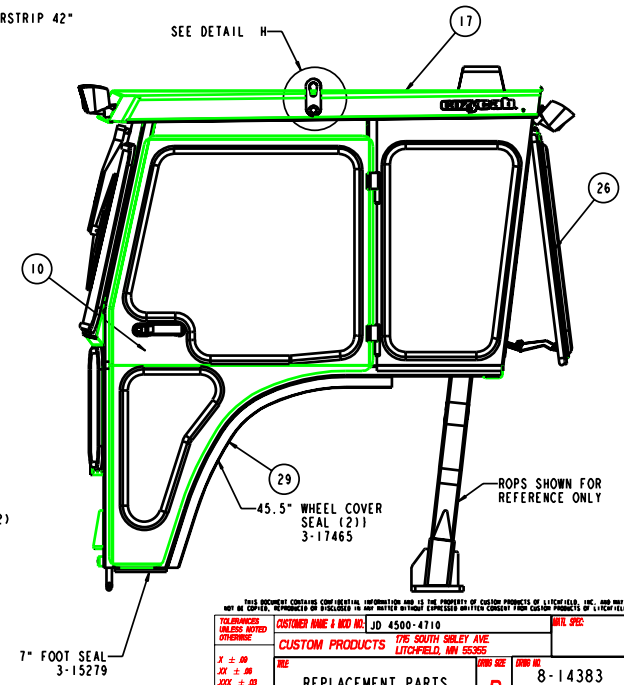
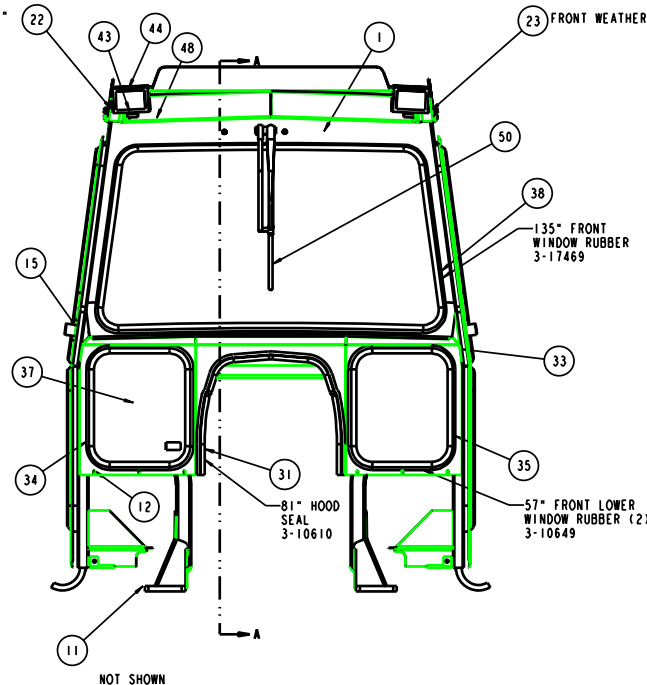
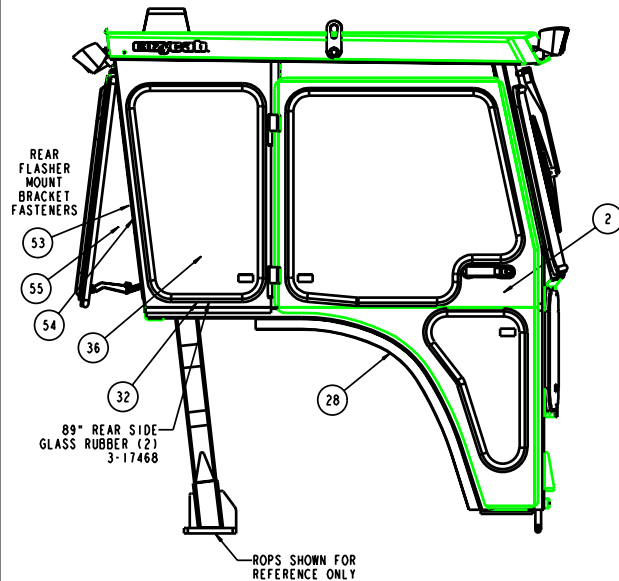

SCALE 0.125

TOLERANCES UNLESS NOTED OTHERWISE		CUSTOMER NAME & MFG NO: JD 4500-4710		FILE NO:
X ± .00		CUSTOM PRODUCTS 176 SOUTH SIBLEY AVE		DRW NO: 8-14383
X/2 ± .00		LITOPFIELD, MN 55355		REV LEVEL: 1 of 2
X/3 ± .00		REPLACEMENT PARTS MAIN CAB ASSEMBLY		DRW CAD: 4-23-02
X/4 ± .00		SCALE: 1/8" = 1"		
X/5 ± .00		ANGLE: ± 5°		

**John Deere 4500, 4510, 4600, 4610, 4700 & 4710
A-11202 Replacement Parts**

RIGHT DOOR ASSEMBLY DRAWING 8-14384

<u>DRAWING ITEM NO.</u>	<u>CUSTOM PROD. PART NO.</u>	<u>ITEM DESCRIPTION</u>
1	7-15368	WELDMENT, RIGHT DOOR
2-3	3-10649	WINDOW RUBBER, 1/8" OFFSET, FOR 1/4" THICK GLASS
4	3-17471	GLASS, UPPER DOOR (7/32" THICK)
5	3-17472	GLASS, LOWER DOOR (7/32" THICK)
6	3-15640	ROTARY LATCH, RIGHT HAND (FOR P/B HANDLE)
7	3-10106	SCREW, 1/4-20 NC X 5/8" LONG, BUTTON HEAD, TOREX
8	3-10147	HEX-HEAD BOLT, 3/8-16 NC X 1" LONG, GRD 5
9	3-10078	WASHER, 3/8" LOCK
10	3-10065	HEX NUT, 3/8-16 NC
11	3-14231	KNOB, ROUND, WITH 3/8-16 NC INSERT
12	3-10076	WASHER, 1/4" LOCK
13	3-12692	HEX-HEAD BOLT, M6-15 X 1" LONG, GRD 8.8
14	3-15574	HANDLE, BLACK, PUSH BUTTON
15	3-11741	HOLE PLUG, BLACK PLASTIC, FOR 3/4" DIA HOLE
16	3-11821	BALL STUD, GAS SPRING, 10MM
17	3-10077	WASHER, 5/16" LOCK
18	3-10064	HEX NUT, 5/16-18 NC

REV.	DCR NO.	DESCRIPTION	DRAFTSMAN	DATE
------	---------	-------------	-----------	------

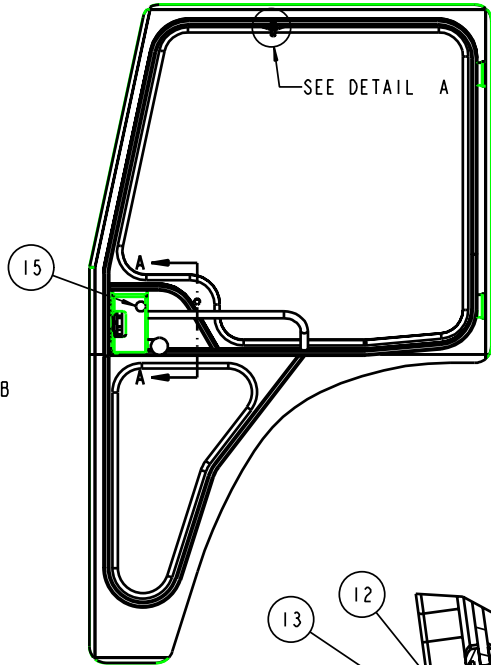
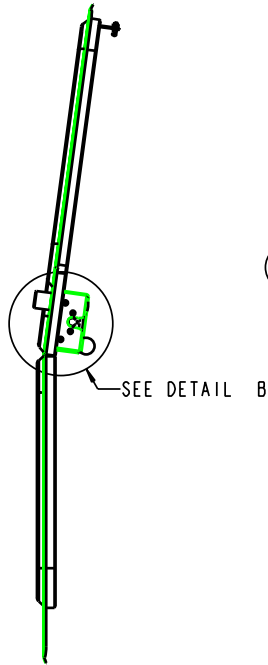
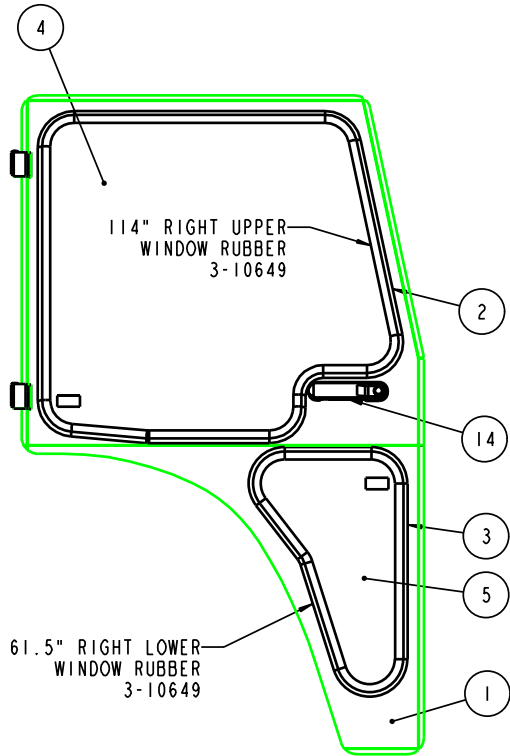

61.5" RIGHT LOWER WINDOW RUBBER 3-10649

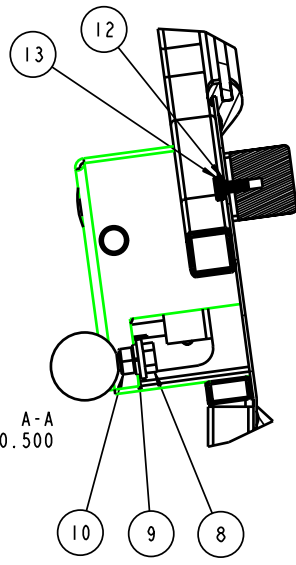

SECTION A-A
SCALE 0.500

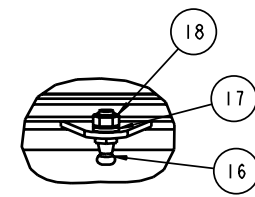

DETAIL A
SCALE 0.500

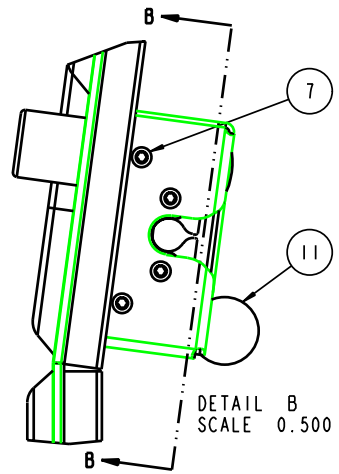

DETAIL B
SCALE 0.500

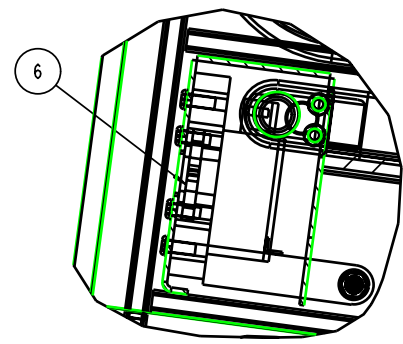

SECTION B-B
SCALE 0.500

TOLERANCES UNLESS NOTED OTHERWISE X ± .09 XX ± .06 XXX ± .03 HOLE SIZE DIA/Ø ANGLE ± 5°	CUSTOMER NAME & MOD NO: JOHN DEERE 4500-4710 CUSTOM PRODUCTS 1715 SOUTH SIBLEY AVE. LITCHFIELD, MN 55355		MTRL SPEC:
	TITLE REPLACEMENT PARTS ASSEMBLY, RIGHT DOOR	DRWG SIZE C	DRWG NO. 8-14384
DRAWN SAW DATE 6/1/00			

**John Deere 4500, 4510, 4600, 4610, 4700 & 4710
A-11202 Replacement Parts**

LEFT DOOR ASSEMBLY DRAWING 8-14385

<u>DRAWING ITEM NO.</u>	<u>CUSTOM PROD. PART NO.</u>	<u>ITEM DESCRIPTION</u>
1	7-15369	WELDMENT, LEFT DOOR
2-3	3-10649	WINDOW RUBBER, 1/8" OFFSET, FOR 1/4" THICK GLASS
4	3-17471	GLASS, UPPER DOOR (7/32" THICK)
5	3-17472	GLASS, LOWER DOOR (7/32" THICK)
6	3-15567	ROTARY LATCH, LEFT HAND (FOR P/B HANDLE)
7	3-10106	SCREW, 1/4-20 NC X 5/8" LONG, BUTTON HEAD, TOREX
8	3-10147	HEX-HEAD BOLT, 3/8-16 NC X 1" LONG, GRD 5
9	3-10078	WASHER, 3/8" LOCK
10	3-10065	HEX NUT, 3/8-16 NC
11	3-14231	KNOB, ROUND, WITH 3/8-16 NC INSERT
12	3-10076	WASHER, 1/4" LOCK
13	3-12692	HEX-HEAD BOLT, M6-15 X 1" LONG, GRD 8.8
14	3-15574	HANDLE, BLACK, PUSH BUTTON
15	3-11741	HOLE PLUG, BLACK PLASTIC, FOR 3/4" DIA HOLE
16	3-11821	BALL STUD, GAS SPRING, 10MM
17	3-10077	WASHER, 5/16" LOCK
18	3-10064	HEX NUT, 5/16-18 NC

REV.	DCR NO.	DESCRIPTION	DRAFTSMAN	DATE
------	---------	-------------	-----------	------

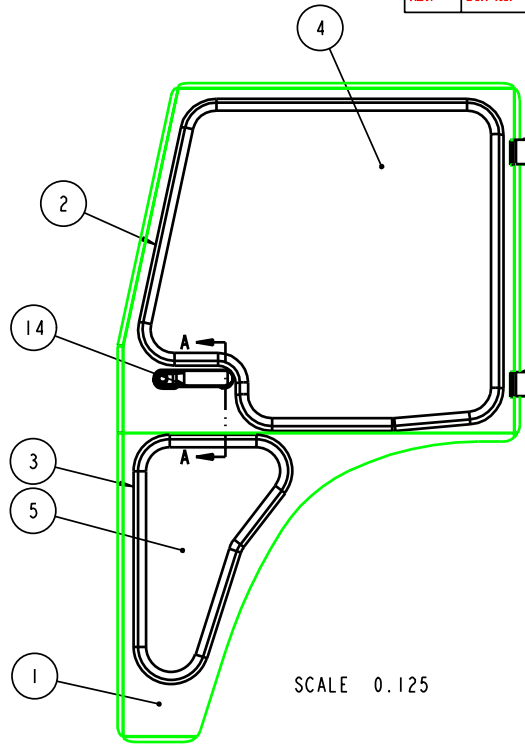
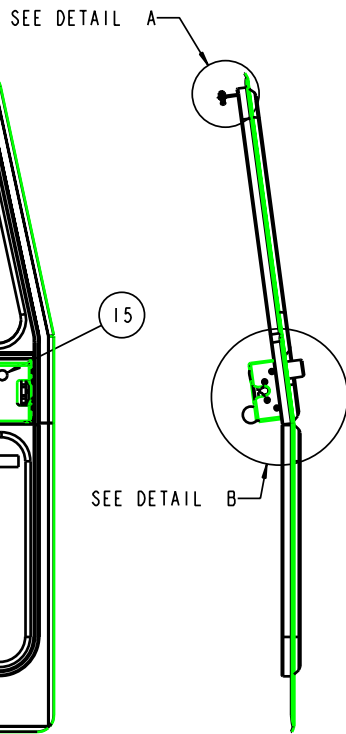

SCALE 0.125

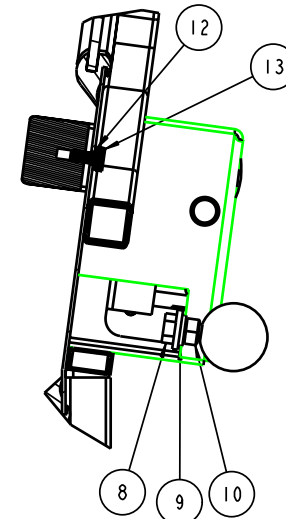

SECTION A-A
SCALE 0.500

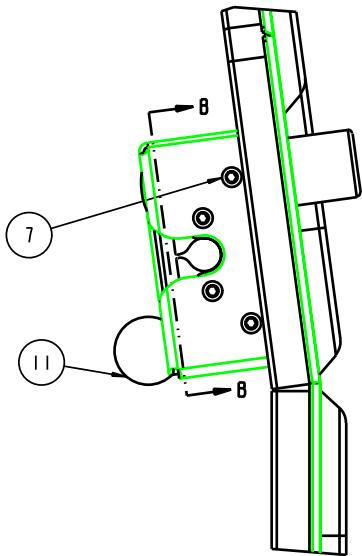

DETAIL B
SCALE 0.500

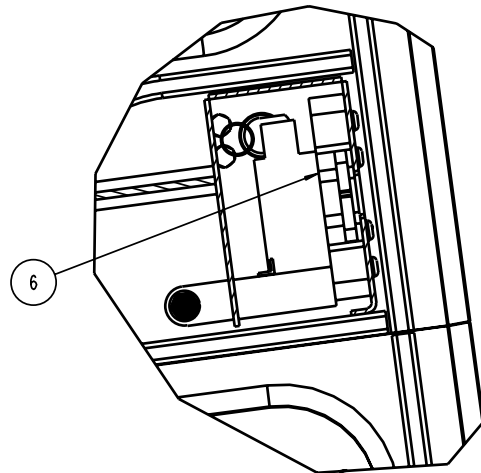

SECTION B-B
SCALE 0.500

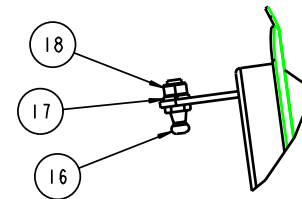

DETAIL A
SCALE 0.500

TOLERANCES UNLESS NOTED OTHERWISE X ± .09 XX ± .06 XXX ± .03 HOLE SIZE DRA/NO ANGLE ± 5°	CUSTOMER NAME & MOO NO: JOHN DEERE 4500-4710 CUSTOM PRODUCTS 1715 SOUTH SIBLEY AVE. LITCHFIELD, MN 55355		MNTL SPEC:
	TITLE REPLACEMENT PARTS ASSEMBLY, LEFT DOOR	DRAWING SIZE C	DRAWING NO. 8-14385
DRAWN SAW DATE 6/2/00			

**John Deere 4500, 4510, 4600, 4610, 4700 & 4710
A-11202 Replacement Parts**

MOUNT KIT DRAWING 8-14386

<u>DRAWING</u>	<u>CUSTOM PROD.</u>	<u>ITEM</u>
<u>ITEM NO.</u>	<u>PART NO.</u>	<u>DESCRIPTION</u>
1	7-15370	WELDMENT, REAR MOUNT
2	3-16635	RUBBER MOUNT, ISOLATION
3	3-16830	WASHER, 1/2" FLAT, WIDE
4	3-15057	HEX-HEAD BOLT, 1/2-13 NC X 3-1/4" LONG, GRD 5
5	3-10379	HEX NUT, NYLOCK, 1/2-13 NC
6	3-12466	WASHER, 1/2" FLAT
7	3-10130	HEX-HEAD BOLT, 1/2-13 NC X 2" LONG, GRD 5
8	6-40872	RIGHT FRONT MOUNT BRACKET, TRACTOR
9	6-40888	LEFT FRONT MOUNT BRACKET, TRACTOR
10	6-41217	STAND-OFF FOR SMV SIGN
11	6-40606	SPACER, RUBBER MOUNT
12	3-17489	U-BOLT, 1/2-13 NC, 4" WIDE X 5-1/8" LONG
13	8-14391	ASSEMBLY, RIGHT FOOT POCKET
14	8-14392	ASSEMBLY, LEFT FOOT POCKET
15	3-14927	SCREW, #10-24 NC X 5/8" LONG, HEX-HEAD, SERFLING
16	8-14417	ASSEMBLY, CENTER REAR SEAL PANEL
17	8-14418	ASSEMBLY, RIGHT REAR SEAL PANEL
18	8-14419	ASSEMBLY, LEFT REAR SEAL PANEL
19	7-15562	WELDMENT, RIGHT FLASHER GUARD
20	7-15661	WELDMENT, LEFT FLASHER GUARD
21	3-10083	WASHER, 3/16" FLAT
22	3-10076	WASHER, 1/4" LOCK
23	3-10002	HEX-HEAD BOLT, 1/4-20 NC X 5/8" LONG, GRD 5
24	3-10729	GROMMET, SNAP BUSHING, FOR 1/2" DIA MNTG HOLE
25	3-10078	WASHER, 3/8" LOCK
26	3-10123	HEX-HEAD BOLT, M8-25 X 1-1/4" LONG, GRD 8.8
27	3-10085	WASHER, 5/16" FLAT
28	8-14593	HEATER HOOKUP KIT
29	05-10357	INSTRUCTION MANUAL FOR JD 4500-4710 MODELS
30	3-17878	PROTECTIVE MAT RIGHT (6-41211)
31	3-17879	PROTECTIVE MAT LEFT (6-41212)
32	3-17880	PROTECTIVE MAT UNDERSEAT (6-41213)
33	3-17803	UNIVERSAL WIRE RELAY BREAKER HARNESS
34	8-14258	CAB TO FRAME GROUNDING WIRE ASSEMBLY
35	7-15446	STEP EXTENSION
36	6-41222	BACKING PLATE FOR STEP EXTENSION
37	3-13849	BAG (NOT A REPLACEMENT PART)
38	3-10219	HEX HEAD CAP SCREW, 1/4-20UNC x 3/4" LG
39	3-17749	BOX, 17 x 42.75 x 9.75 (NOT A REPLACEMENT PART)
40	3-17750	BOX, 8 x 11.5 x 19 (NOT A REPLACEMENT PART)
41	3-10383	HEX HEAD CAP SCREW, 1/4-20UNC x 1-3/4" LG
42	3-10070	HEX NUT, NYLOCK, 1/2-13 NC
43	3-10046	HEX HEAD CAP SCREW, 1/2-13UNC x 1.5 GR 5

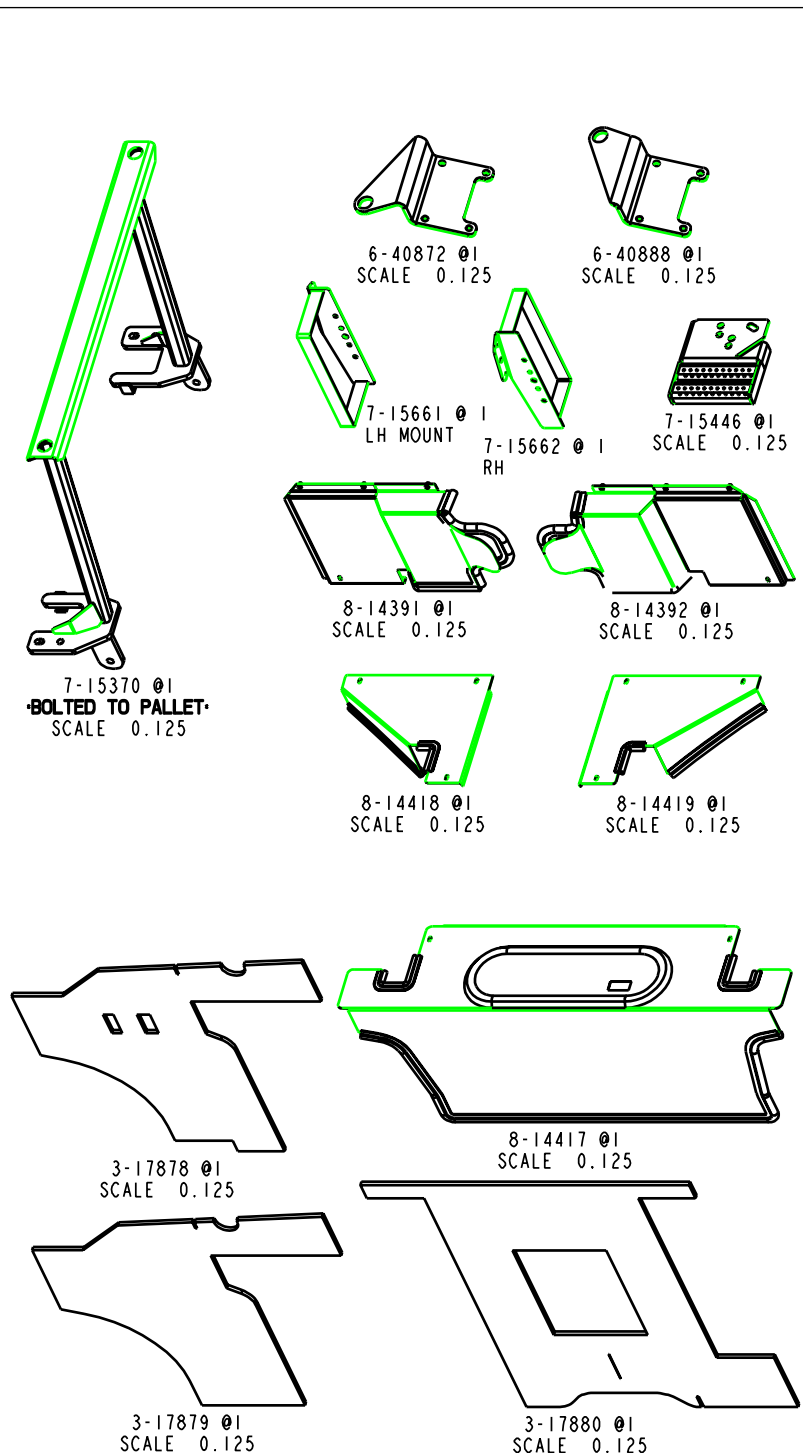

REV.	DCR NO.	DESCRIPTION	DRAFTSMAN	DATE
A			TEO	8/18/00
B	7521	REPLACED BOX 3-15102 WITH 3-17749 & 3-17750	TEO	12/17/01
C	PL 4-19-02	INCORPORATED SERIES "10" MODELS	CAD	8/15/02

THE FOLLOWING MOUNT KIT
HARDWARE PARTS SHOULD BE
PLACED IN PARTS BAG (3-13849):

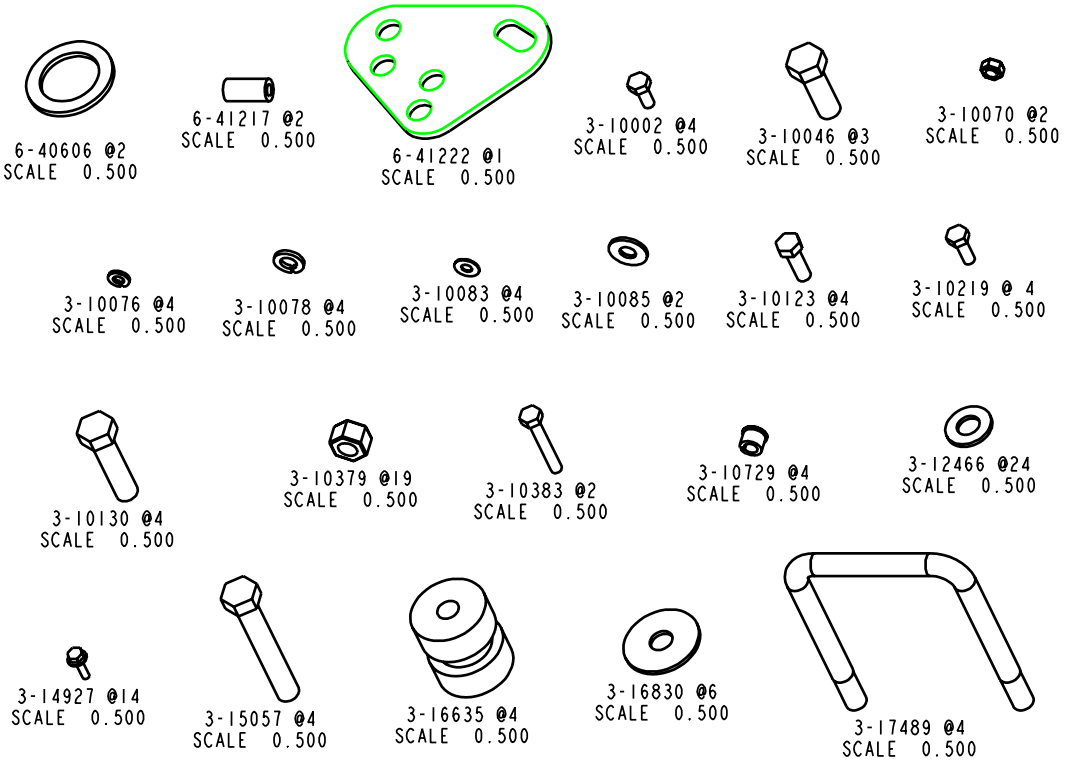

PACKAGE ALL PARTS AS SHOWN
AND PLACE IN BOXES
(3-17749 & 3-17750)
UNLESS OTHERWISE NOTED.

ADDITIONAL PARTS TO BE PLACED
IN MOUNT KIT BOX:

- 8-14593 (01) "HEATER KIT" (COMES IN OWN BOX)
- 05-10357 (01) "MOUNTING INSTRUCTIONS"

THE FOLLOWING MOUNT KIT
ELECTRICAL PARTS SHOULD BE
PLACED IN A CLEAR BAG:

- 3-17803 @1 QTY "UNIVERSAL WIRE RELAY HARNESS"
- 8-14258 (01) "WIRE ASSY, CAB/GND"

TOLERANCES UNLESS NOTED OTHERWISE	CUSTOMER NAME & MOD NO: JOHN DEERE 4500-4710		MATL. SPEC:
	CUSTOM PRODUCTS 175 SOUTH SIBLEY AVE LITCHFIELD, MN 55355		
X ± .09 XX ± .06 XXX ± .03 HOLE SIZE 1/16" DIA ANGLE ± 5°	TITLE	DWG. SIZE	DWG. NO.
	ASSEMBLY, MOUNT KIT	C	8-14386
			REV LEVEL C
		DRAWN: TEO	DATE: 7/17/00

**John Deere 4500, 4510, 4600, 4610, 4700 & 4710
A-11202 Replacement Parts**

HEADLINER ASSEMBLY DRAWING 8-14387

<u>DRAWING</u> <u>ITEM NO.</u>	<u>CUSTOM PROD.</u> <u>PART NO.</u>	<u>ITEM</u> <u>DESCRIPTION</u>
1	3-16232	DOMELIGHT, RECTANGULAR, 12V
2	3-16984	SCREW, #6-32 NC X 1-1/2" LONG, ROUND HEAD, SLOTTED
3	3-10088	WASHER, 3/16" LOCK
4	3-12637	HEX NUT, #6-32
5	6-40504	SWITCH PLATE, HEATER/FAN
6	3-11812	SCREW, #10 SELFTAP X 3/4" LONG, PAN HEAD, PHILLIPS
7	3-15432	BLOWER SWITCH, 3-SPEED ROTARY
8	3-11173	KNOB, BLOWER SWITCH
9	3-11149	CABLE ASSEMBLY, HEATER CONTROL, WITH PULL KNOB
10	6-40505	COVER PLATE, FUSE BLOCK
11	3-15926	FUSE BLOCK, 10 CIRCUIT, FOR ATO/ATC FUSES
12	3-10099	SCREW, #10-24 NC X 1-1/2" LONG, ROUND HEAD, SLOT
13	3-10308	HEX NUT, NYLOCK, #10-24 NC
14	3-16580	FUSE, ATO/ATC, 30 AMP
15	3-16581	FUSE, ATO/ATC, 7-1/2 AMP
16	3-16582	FUSE, ATO/ATC, 2 AMP
17	3-16057	FUSE, ATO/ATC, 10 AMP
18	6-40506	SWITCH PLATE, WIPER/LIGHTS
19	3-16274	ROCKER SWITCH, ON/OFF
20	3-16677	PLUG, ROCKER SWITCH HOLE
21	3-10729	GROMMET, SNAP BUSHING, FOR 1/2" DIA MNTG HOLE
22	3-10730	GROMMET, SNAP BUSHING, FOR 1-3/8" DIA MNTG HOLE
23	3-11741	HOLE PLUG, BLACK PLASTIC, FOR 3/4" DIA HOLE
24	3-15594	LOUVER, BLACK ROUND ,FIT 3-3/64" DIA HOLE, ADJ
25	3-15928	LOUVER, BLACK ROUND ,FIT 3-3/64" DIA HOLE, FIXED
26	3-11202	GASKET, SQUARE BLOWER
27	3-15935	BLOWER, DUAL WHEEL, 12 VOLT, 235 CFM
28	3-10105	SCREW, #10-24 NC X 3/4" LONG, TRUSS HEAD, PHILLIPS
29	3-16572	HEATER CORE, 5/8" DIA HOSE FITTINGS
30	3-16672	MOUNTING CLIP, HEATER CORE
31	3-16692	VALVE, HEATER CONTROL, 5/8" DIA HOSE FITTINGS
32-37	3-11172	HEATER HOSE, 5/8" INSIDE DIA
38	3-10282	PLASTIC ELBOW, FOR 5/8" DIA HOSE, 90 DEGREE
39	3-10858	HOSE CLAMP, #10 SCREW, RANGE DIA 9/16" TO 1-1/16"
40	3-17319	RUBBER, D-SEAL, 3/4" HIGH X 3/4" WIDE, PSA BACK
41	6-41110	INSULATION, 1/4" HEATHER CHARCOAL, CENTER
42	6-41111	INSULATION, 1/4" HEATHER CHARCOAL, REAR
43	6-41112	INSULATION, 1/4" HEATHER CHARCOAL, RIGHT SIDE
44	6-41113	INSULATION, 1/4" HEATHER CHARCOAL, LEFT SIDE
45	6-41114	INSULATION, 1/4" HEATHER CHARCOAL, FRONT

REV.	DCR NO.	DESCRIPTION	DRAFTSMAN	DATE
------	---------	-------------	-----------	------

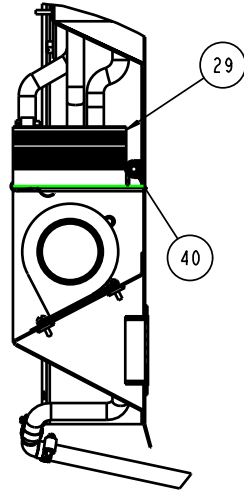

SECTION A-A
SCALE 0.250

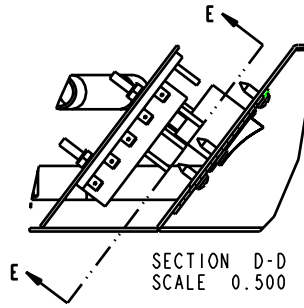

SECTION D-D
SCALE 0.500

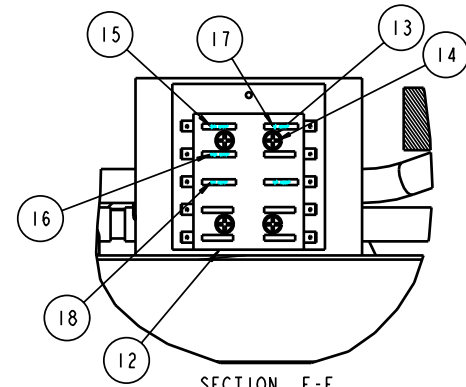

SECTION E-E
SCALE 0.500

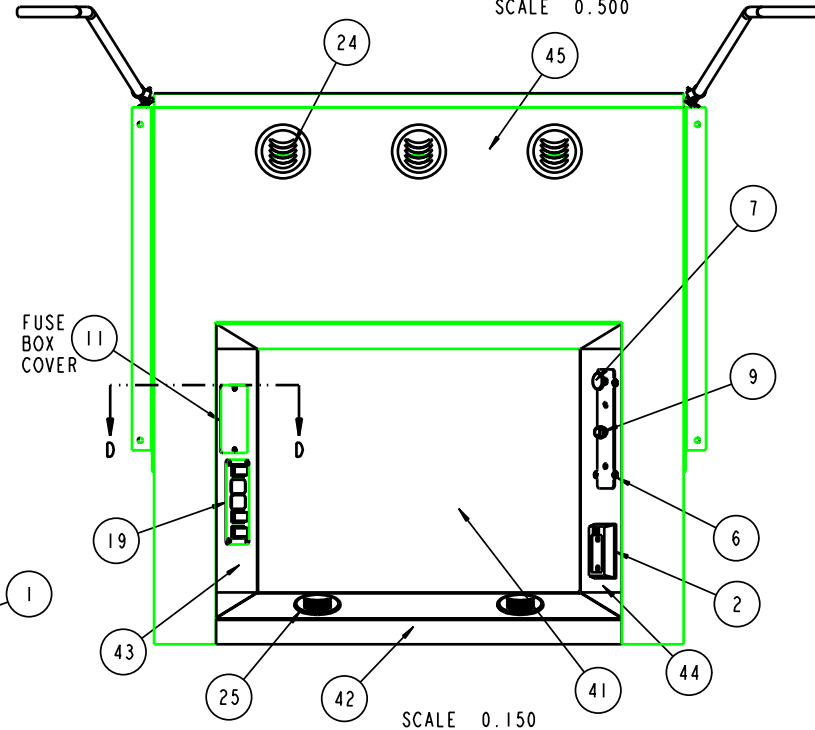

SCALE 0.150

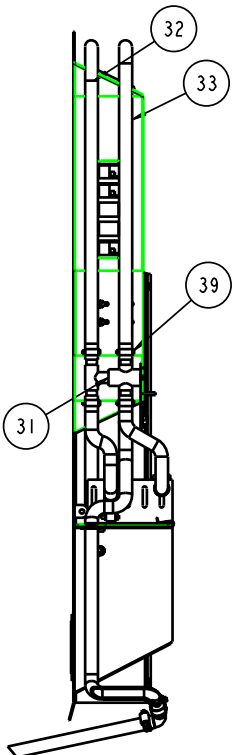

SECTION B-B
SCALE 0.188

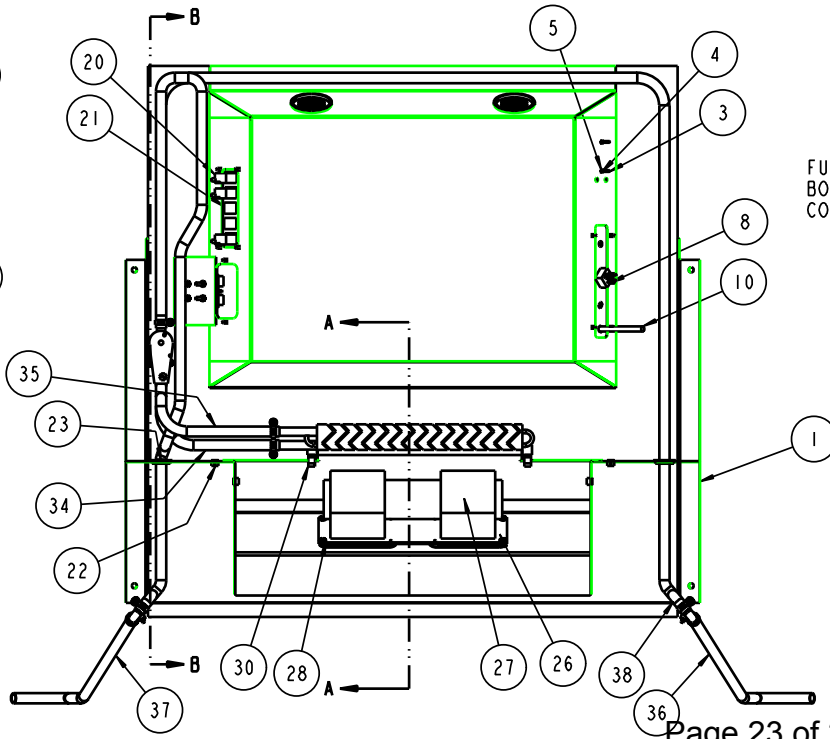

TOP VIEW
SCALE 0.150

HOT-PRESSURE LINE
ROUTES DOWN RIGHT
CAB FRAME TUBE

RETURN LINE ROUTES
DOWN LEFT CAB
FRAME TUBE

TOLERANCES UNLESS NOTED OTHERWISE X ± .09 XX ± .06 XXX ± .03 HOLE SIZE 1/8" - 10 ANGLE ± 5°	CUSTOMER NAME & MOD NO: JOHN DEERE 4500-4710		MATL SPEC:
	CUSTOM PRODUCTS 1715 SOUTH SIBLEY AVE LITCHFIELD, MN 55355		
TITLE REPLACEMENT PARTS ASSEMBLY, HEADLINER	DRWG SIZE C	DRWG NO. 8-14387	REV LEVEL 1 of 1
DRAWN BY DATE 6/2/00			1 of 1

**John Deere 4500, 4510, 4600, 4610, 4700 & 4710
A-11202 Replacement Parts**

REAR HINGED WINDOW ASSEMBLY DRAWING 8-14400

<u>ITEM NO.</u>	<u>PART NO.</u>	<u>DESCRIPTION</u>
1	7-15396	WELDMENT, REAR HINGED WINDOW
2	3-15952	SEAL RUBBER, 3/4" OD BUBBLE, UP TO 1/8" MATERIAL
3	3-10649	WINDOW RUBBER, 1/8" OFFSET, FOR 1/4" THICK GLASS
4	3-17485	GLASS, REAR HINGED WINDOW (7/32" THICK)
5	3-13931	HEX-HEAD BOLT, 1/4-20 NC X 4-1/2" LONG, GRD 5
6	3-10070	HEX NUT, NYLOCK, 1/4-20 NC
7	3-15234	HOLE PLUG, BLACK PLASTIC, FOR 11/16" DIA HOLE
8	3-10721	HOLE PLUG, BLACK PLASTIC, FOR 3/8" DIA HOLE
9	3-16831	T-HANDLE LATCH, BLACK PLASTIC
10	3-16832	PIN, QUICK RELEASE, 3/16" DIA X 1" LONG
11	3-15576	ROLL PIN, T-HANDLE, 3/16" DIA X 1/2" LONG

CENTER REAR SEAL PANEL DRAWING 8-14417

<u>ITEM NO.</u>	<u>PART NO.</u>	<u>DESCRIPTION</u>
1	6-41087	CENTER REAR SEAL PANEL
2	3-17506	GLASS, REAR SEAL PANEL (7/32" THICK)
3	3-10649	WINDOW RUBBER, 1/8" OFFSET, FOR 1/4" THICK GLASS
4	3-10610	SEAL RUBBER, CLIP-ON BUBBLE, 180 DEGREE
5	3-15068	TRIM SEAL, 3/8" BUBBLE, 180 DEGREE

HEATER HOOK UP COMPONENTS DRAWING 8-14593

<u>ITEM NO.</u>	<u>PART NO.</u>	<u>DESCRIPTION</u>
1	3-17756	FITTING, 3/8-19 BSPT TO 5/8" HOSE NIPPLE
2	3-10282	HOSE ELBOW, 5/8" ID x 90 DEGREE PLASTIC
3	3-10725	NYLON WIRE TIE, 7.50" LG
4	3-11172	HOSE, HEATER 5/8" ID
5	3-10858	HOSE CLAMP 5/8" NUMBER 10
6	3-16265	BAG 10x12, ZIP LOCK (PACKAGING)
7	3-12119	FITTING, 3/8-18 NPT TO 5/8" HOSE NIPPLE

REV.	DCR NO.	DESCRIPTION	DRAFTSMAN	DATE
------	---------	-------------	-----------	------

143" REAR WINDOW
SEAL RUBBER
3-15952

118" REAR
WINDOW RUBBER
3-10649

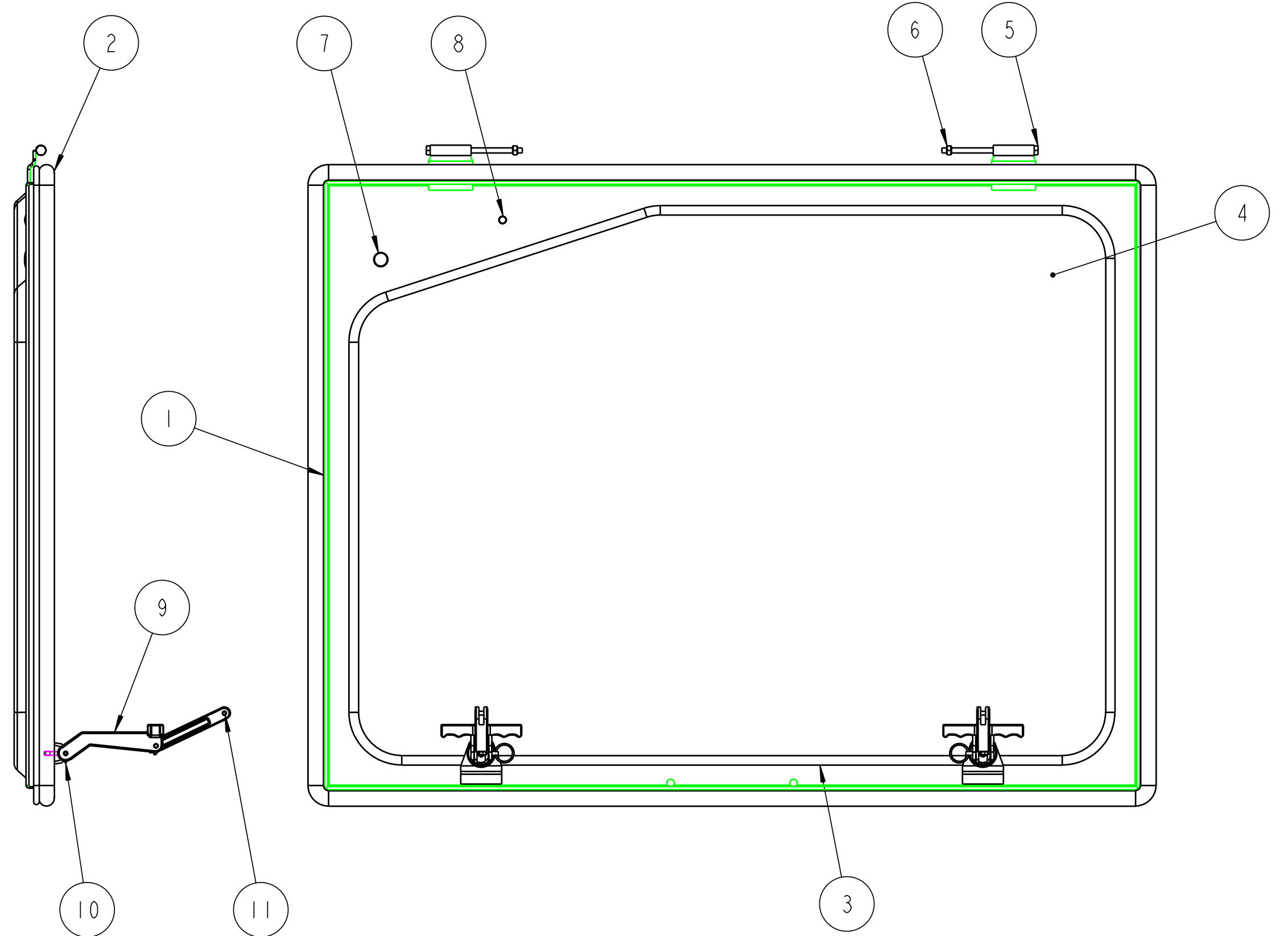
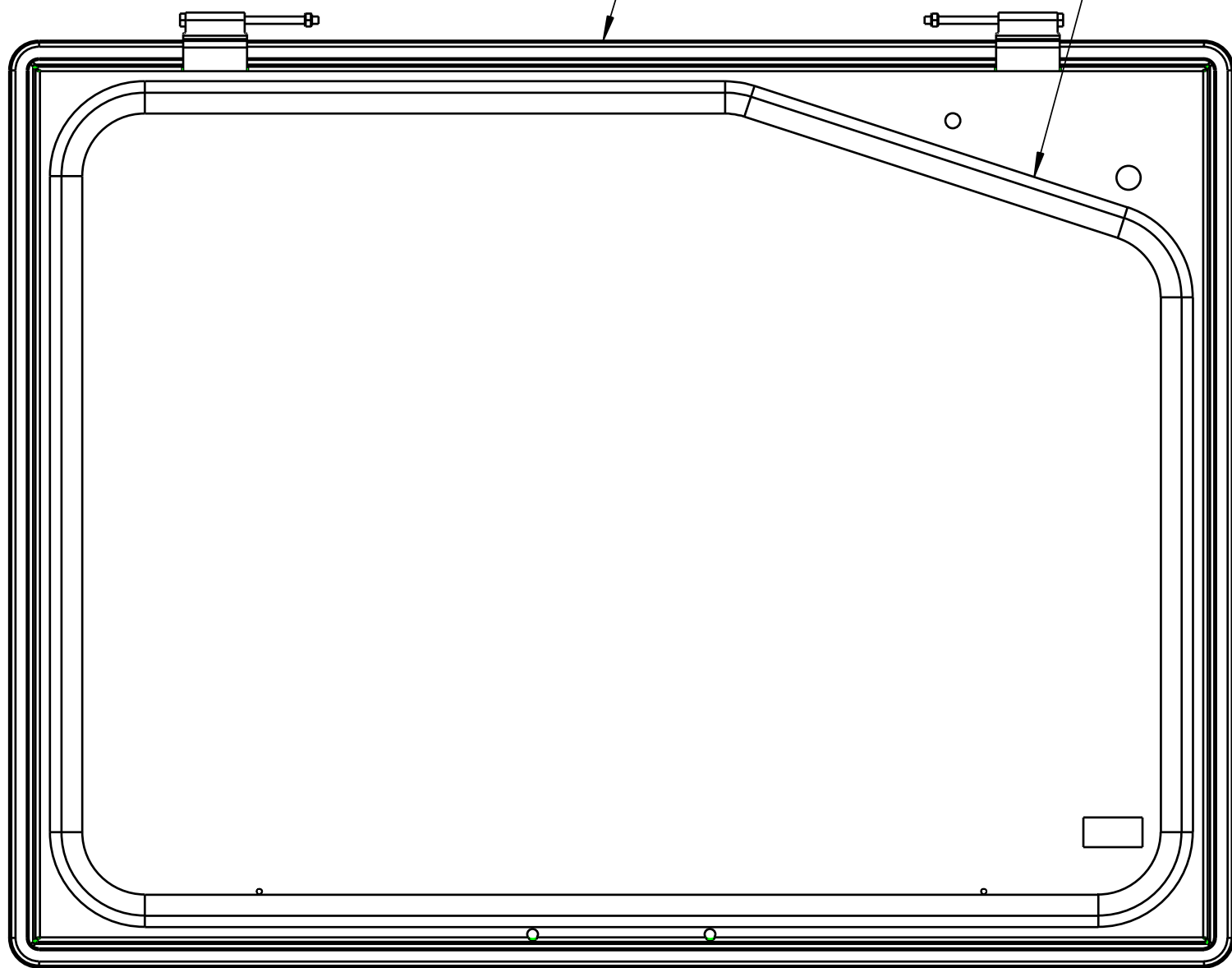

TOLERANCES UNLESS NOTED OTHERWISE	CUSTOMER NAME & MOD NO: JOHN DEERE 4500-4710		MATERIAL SPEC:		
	CUSTOM PRODUCTS 1715 SOUTH SIBLEY AVE. LITCHFIELD, MN 55355				
.X ± .09 .XX ± .06 .XXX ± .03 HOLE SIZE .015/-.010 ANGLE ± 5°	TITLE REPLACEMENT PARTS ASSEMBLY, REAR HINGED WINDOW		DRWG SIZE C	DRWG NO. 8-14400	REV LEVEL
DRAWN: SAW DATE: 6/5/00					

REV.	DCR NO.	DESCRIPTION	DRAFTSMAN	DATE
------	---------	-------------	-----------	------

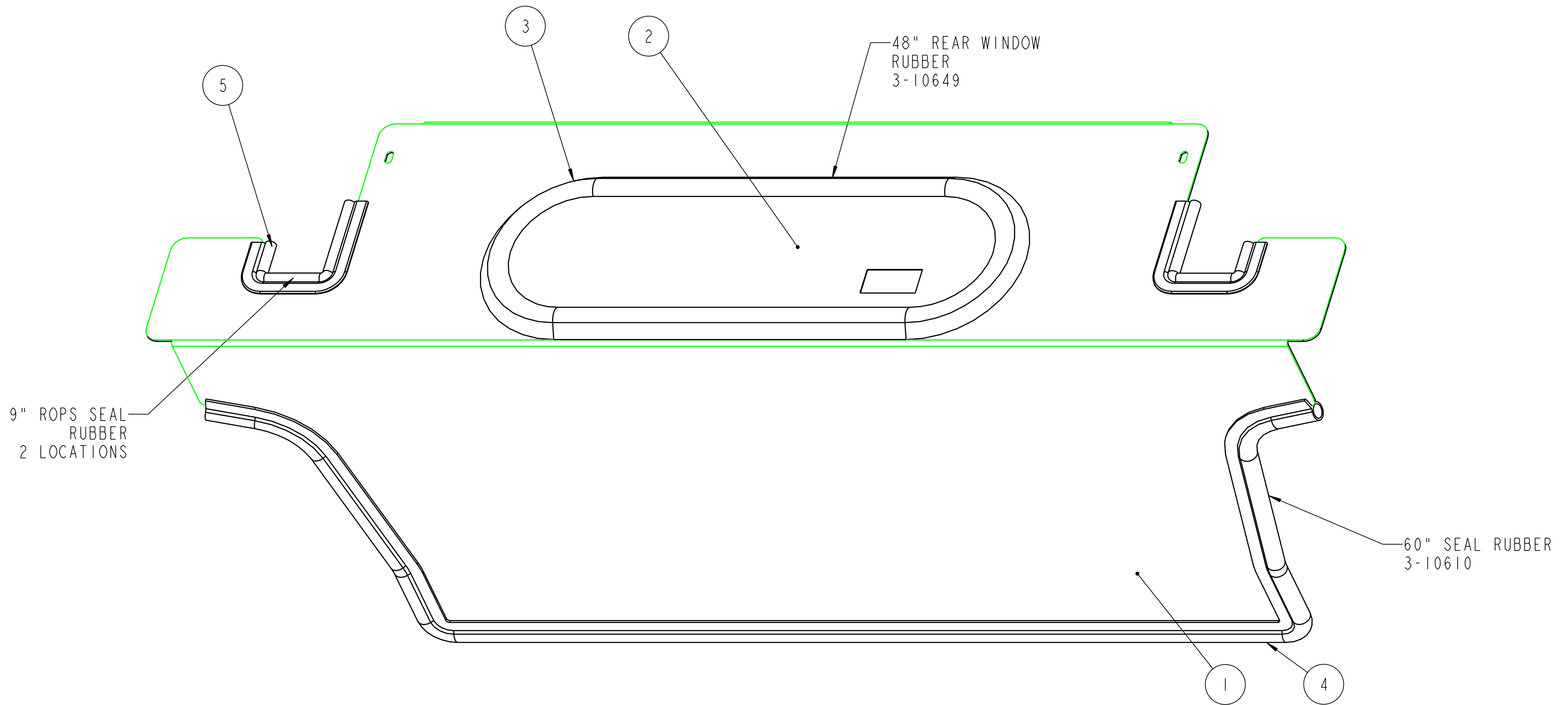

TOLERANCES UNLESS NOTED OTHERWISE .X ± .09 .XX ± .06 .XXX ± .03 HOLE SIZE .015/.010 ANGLE ± 5°	CUSTOMER NAME & MOD NO: JOHN DEERE 4500-4710		MATERIAL SPEC:	
	CUSTOM PRODUCTS 1715 SOUTH SIBLEY AVE. LITCHFIELD, MN 55355		DRAWING SIZE C	DRAWING NO. 8-14417
TITLE REPLACEMENT PARTS ASSEMBLY, CENTER REAR SEAL PANEL			DRAWN: SAW DATE: 6/6/00	REV LEVEL

REV.	DCR NO.	DESCRIPTION	DRAFTSMAN	DATE

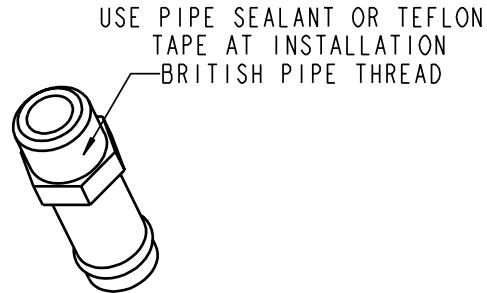

ITEM 1 #3-17756
 3/8-19 "BRITISH" STD PIPE THREAD
 TO 5/8" ID HOSE NIPPLE
 MODELS 4210, 4310 & 4410 ONLY -(2) REQ'D

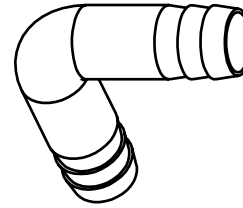

ITEM 2 #3-10282
 HOSE ELBOW 5/8"
 (2 REQ'D)

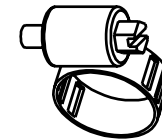

ITEM 5 #3-10858
 HOSE CLAMP 5/8"
 (6) REQ'D

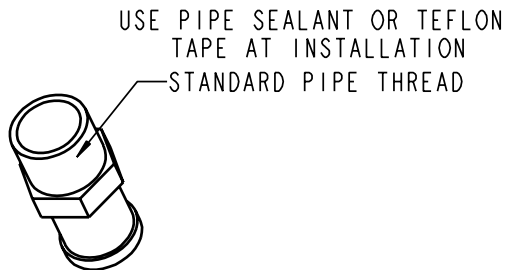

ITEM 7 #3-12119
 3/8-18 NPT
 TO 5/8" ID HOSE NIPPLE
 MODELS 4200, 4300 & 4400 ONLY (2) REQ'D

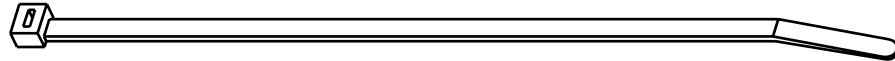

ITEM 3 #3-10725
 NYLON WIRE TIE 7.50"
 (8 REQ'D)

ITEM 4 (NOT SHOWN) - #3-11172, HOSE, HEATER 5/8" x 12 FEET LG
 ITEM 6 (NOT SHOWN) #3-16265 BAG, 10 x 12, ZIPLOCK

THIS DOCUMENT CONTAINS CONFIDENTIAL INFORMATION AND IS THE PROPERTY OF CUSTOM PRODUCTS OF LITCHFIELD, INC. AND MAY NOT BE COPIED, REPRODUCED OR DISCLOSED IN ANY MANNER WITHOUT EXPRESSED WRITTEN CONSENT FROM CUSTOM PRODUCTS OF LITCHFIELD, INC.

TOLERANCES UNLESS NOTED OTHERWISE <i>X</i> ± .09 <i>.XX</i> ± .06 <i>.XXX</i> ± .03 HOLE SIZE <i>.05/-00</i> ANGLE ± .5°	CUSTOMER NAME & MOD NO.: JD -YANMAR ENGINES	MATL SPEC:	
	CUSTOM PRODUCTS 1715 SOUTH SIBLEY AVE. LITCHFIELD, MN 55355		
TITLE HEATER KIT COMPONENTS	DRAWG SIZE: B	DRAWG NO.: 8-14593	REV LEVEL: A
	DRAWN: CAD	DATE: 3-29-02	

REV	DCR/ECO NO.	DESCRIPTION	DRAFTSMAN	DATE
A		UPDATED TO PRO E	CAD	8-6-02

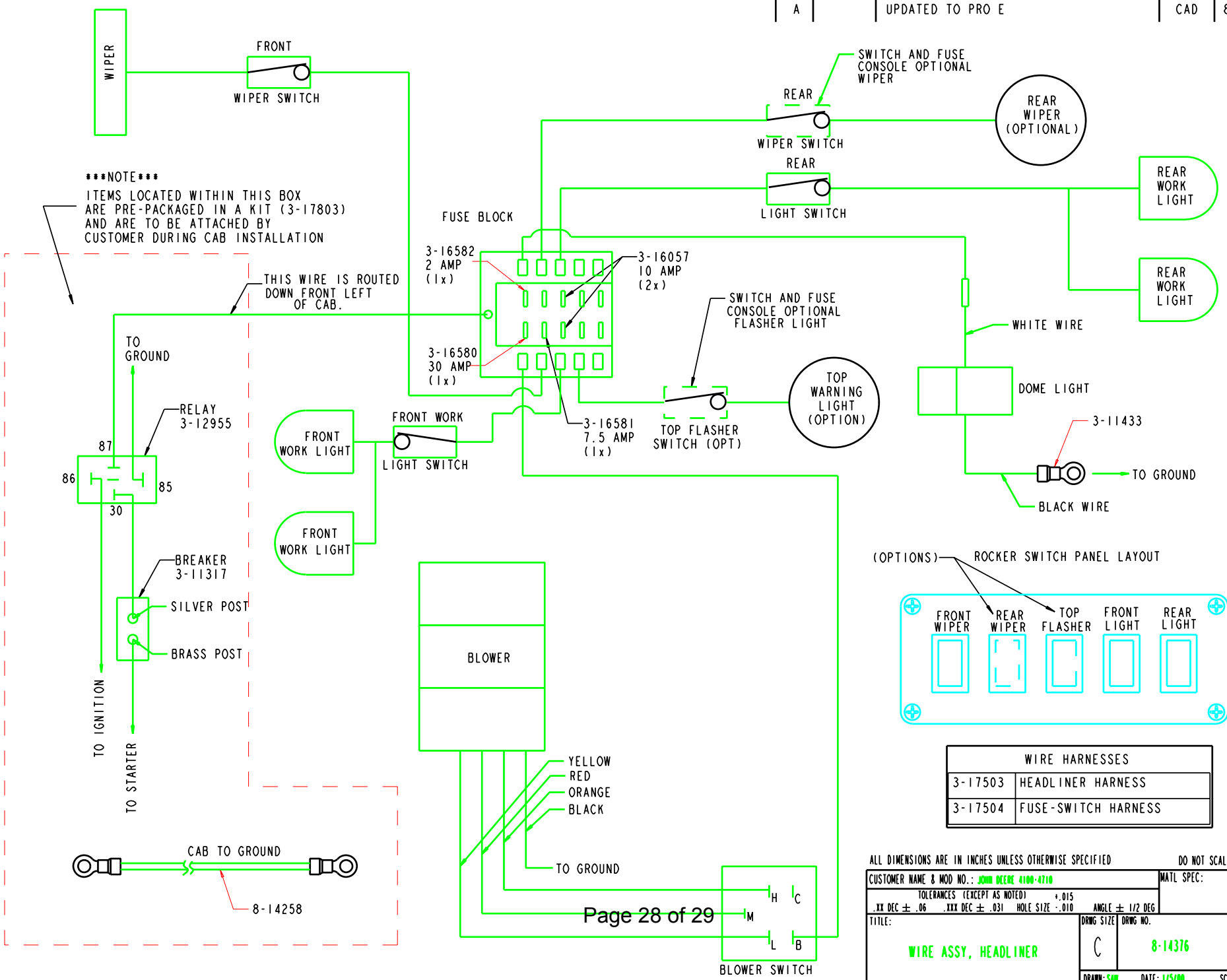

WIRE HARNESSES	
3-17503	HEADLINER HARNESS
3-17504	FUSE-SWITCH HARNESS

ALL DIMENSIONS ARE IN INCHES UNLESS OTHERWISE SPECIFIED DO NOT SCALE DRAWING

CUSTOMER NAME & MOD NO.: JOHN DEERE 4100-4710

TOLERANCES (EXCEPT AS NOTED) .015
 .XX DEC ± .06 .XXX DEC ± .031 HOLE SIZE -.010 ANGLE ± 1/2 DEG

MATL SPEC:

TITLE: WIRE ASSY, HEADLINER	DRWG SIZE C	DRWG NO. 8-14376	REV LEVEL A
DRAWN: SAM		DATE: 1/5/00	SCALE:

REV.	DCR NO.	DESCRIPTION	DRAFTSMAN	DATE
A		RELEASED FOR VENDOR PROCESSING	CAD	4-18-02

ITEM #	DESCRIPTION	QTY
1	3-11317_BREAKER_40_AMP	1
2	3-12955_RELAY_30_AMP_	1
3	3-10305_TERMINAL EYE 10-12 SMALL	2
4	3-10670_SLIDE FEM CON 14 GA	3
5	3-10351_WIRE_12GA_RED_X_8_	1
6	3-10314_WIRE_14GA_BLUE_X_20_	1
7	3-10104_MSCR_NO10_X_63_THSL	2
8	3-10308_1024_NYLOCK_	2
9	3-14553_SLIDE_FEM_10-12_GA_	1
10	3-10351_WIRE_12GA_RED_X_20_	1
11	3-10351_WIRE_12GA_RED_X_180(REFERENCE ONLY)	1
12	3-10340_WIRE_12GA_BLACK_X_12_	1
13	3-11428_TERMINAL_MALE STR	1
14	3-10673_TERMINAL EYE 10-12 GA MED	1
15	3-10674_TERMINAL EYE 10-12 LARGE	1
16	3-10982_WIRE SPLICE BLUE 14-16 GA	1
17	3-10704_DUCT_WIRE_350X24	1
18	3-13083_WASHER_LOCK_EXT_T	4
19	3-16265_BAG_ZIP_10_X_12	SEE BOM

BOM NOTES:
 ITEM 19 - (NOT SHOWN) ALL PARTS
 TO BE PLACED IN THIS BAG

TOLERANCES UNLESS NOTED OTHERWISE	CUSTOMER NAME & MOD NO.:	UNIVERSAL RELAY-BREAKER HARNESS	MATL SPEC:	
	CUSTOM PRODUCTS 1715 SOUTH SIBLEY AVE. LITCHFIELD, MN 55355			
X ± .09 .XX ± .06 .XXX ± .03 HOLE SIZE ANGLE ± .5°	TITLE	DRWG SIZE	DRWG NO.	REV LEVEL
	UNIVERSAL WIRE RELAY BREAKER HARNESS	B	3-17803	A
Page 2 of 2	DRAWN:	CAD	DATE	4-5-02

