

COZYcab™

MOUNTING INSTRUCTIONS

With Replacement Parts Listing For TORO GROUNDSMASTER

580D 2-POST ROPS

A-10798



Manufactured by:



BOX 70 • LITCHFIELD, MINNESOTA 55355
Phone: (320) 693-3221 Fax: (320) 693-7252
1-800-222-5463

Website: www.800cabline.com

OPTIONS

- A-10966 CANOPY
- A-10965 ENTRY STEP
(Not compatible w/mower deck)
- A-10964 WINDSHIELD KIT
(Compatible only w/canopy)

MOUNTING INSTRUCTIONS

With Replacement Parts List for

TORO GROUNDSMASTER 580-D

2-POST ROPS

PLEASE COMPLETELY REVIEW INSTRUCTIONS BEFORE INSTALLING ROPS.

If you have any questions or comments please call 1-800-222-5463 and ask for technical assistance with Toro 580 Series.

PREPARATION OF MACHINE

- A. Remove the air intake cowling from machine shown in Figure #1.

INSTALLATION OF THE 2-POST ROPS

- A. Lower roll bar onto the machine and insert the lower legs into the 3" x 3" mounting tubes shown in Figure 2-A.

NOTE: When the bar is installed it should slope toward the rear of the machine.

- B. Secure the bar with the four 3/4" x 2" bolts and lock washers supplied.
- C. When the roll bar is secure, replace the air intake cowling.

INSTALLATION OF SEAT BELT

- A. Bolt seat belt to holes in the back of the seat using two 7/16" x 1" fine threaded bolts, flat washers and lock washers.



Figure 1

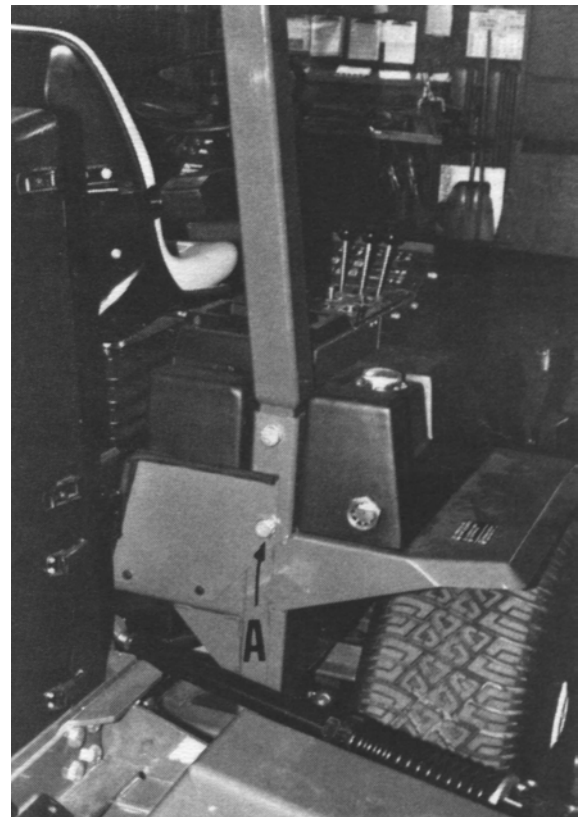
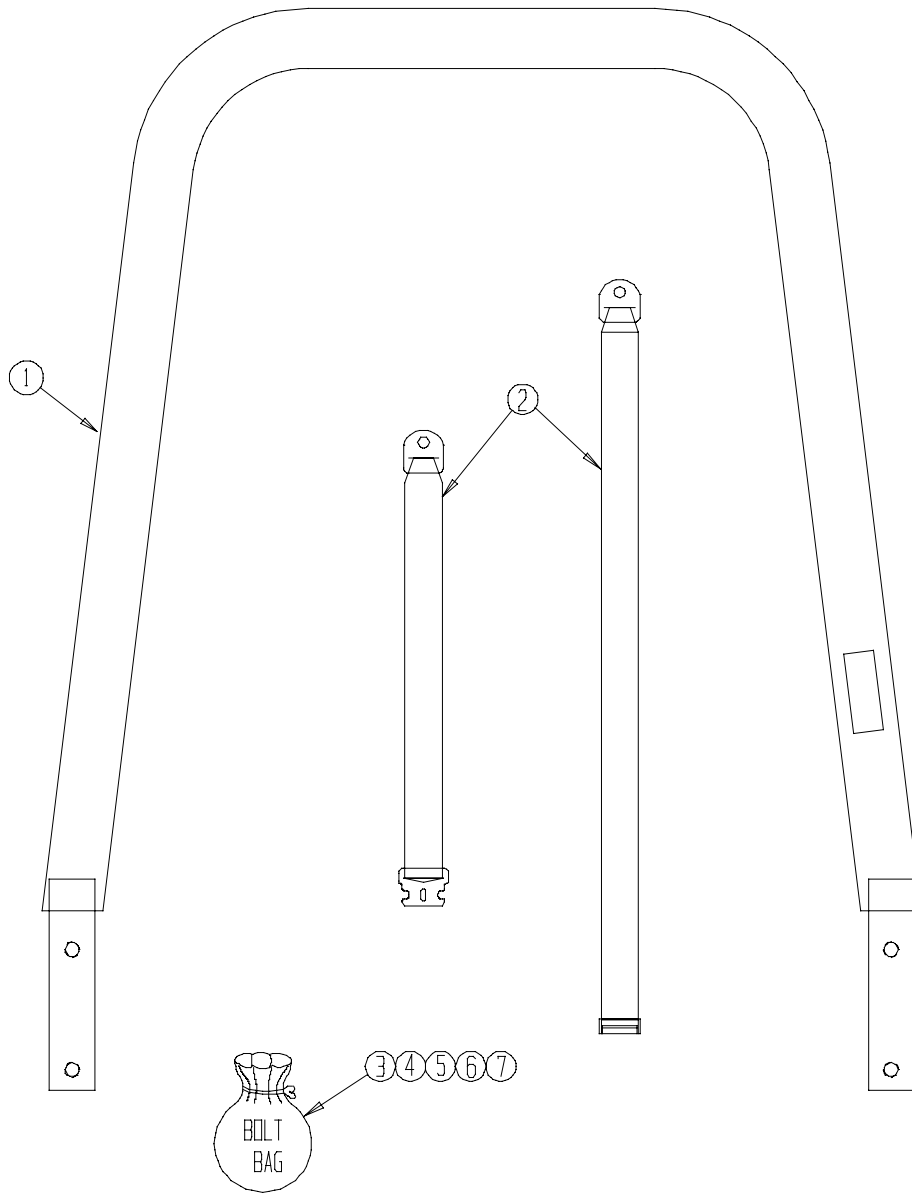

Figure 2



REPLACEMENT PARTS
2-Post ROPS with MOUNTING KIT
To Fit TORO 580-D GROUNDSMASTER
A-10798

<u>ITEM</u>	<u>QTY</u>	<u>PART NO.</u>	<u>DESCRIPTION</u>
		A-10798	2-Post ROPS with MOUNTING KIT Complete
1	1	7-13569	Roll Bar Weldment Only (Unpainted)
2	1	3-10287	Seat Belt
3	4	3-10423	3/4" - 10 x 2" NC Hex Cap Screw - Grade 5
4	4	3-10081	3/4" Lock Washer
5	2	3-13708	7/16" - 20 x 1" NF Hex Cap Screw - Grade 5
6	2	3-10152	7/16" Lock Washer
7	2	3-10166	7/16" Flat Washer
8		Not Used	
9	1	05-10268	Instruction/Parts Manual